



Modular electric deck oven

2 decks composition

Amalfi consists of one or more independent baking chambers and an optional proofer or stand. The baking chamber is entirely made of refractory stone with coiled heating elements inside, allowing the perfect heat distribution over the whole surface. This oven is particularly suitable for direct pizza baking, specific for more delicate toppings and recommended for indirect baking on trays. Temperature management is electronic, power control of ceiling and floor is independent. The oven door is hinged at the bottom, with a tempered glass window to check the product during baking. The stand consists of a painted metal structure, while the proofer is a stainless steel cabinet equipped with a heating thermostat. The proofer can reach the maximum temperature of 65°C(149°F), whereas the maximum temperature of the baking chamber is 450°C (842°F).



OPERATION

- Heated by spiral heating elements
- Electronic temperature management with independent adjustment of ceiling and floor
- Maximum temperature reached 450°C (842°F)
- Continuous temperatures monitoring in baking chamber by thermocouple
- Vapour ducting using manual butterfly valve

CONSTRUCTION

- Structure made in folded stainless steel
- Side panels in painted sheet metal
- Hood in stainless steel
- Steam duct in stainless steel plate
- Stainless steel door, tempered glass
- Refractory top and side structure
- Dual halogen lighting
- Rock wool heat insulation

ACCESSORIES

- Leavening proofer on wheels height 600, 800mm
- Stand with wheels height 600, 800, 950mm
- Spacer element height 300mm
- Additional tray holder guides for compartment and stand
- Motor for hood vapours extraction 500 m3/h
- Self-condensing hood
- Frontless hood

INTERNAL BAKING DIMENSIONS

Internal height	180mm
Internal depth	1040mm
Internal width	650mm
Baking surface	0,7m ²

- Timer
- Economiser
- Independent maximum temperature safety device

TOP VIEW

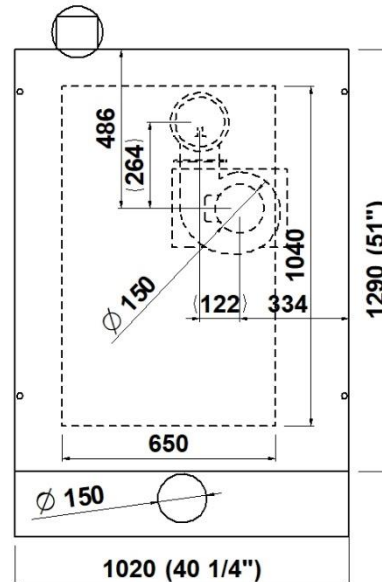

STANDARD EQUIPMENT

- 20 customisable programs

1 baking chamber height 18cm

(assembled with stand height 950mm)

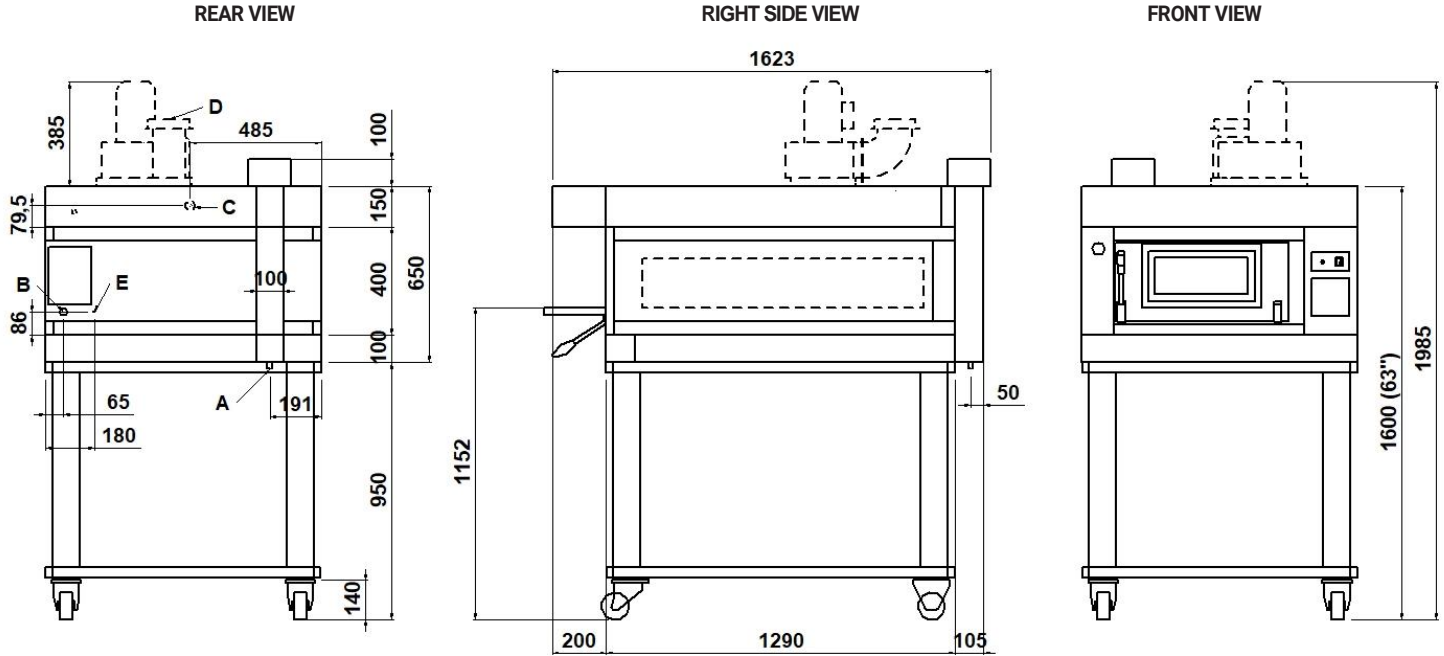

NOTE: The dimensions indicated in the views are in millimeters.

A Ø12 condensate exhaust	B fairleads	C Ø16 hood condensate exhaust	D Ø150 steam exhaust
E M6 equipotential screws			

DIMENSIONS

External height	650mm
External depth	1290mm
External width	1020mm
Weight	222kg

TOTAL BAKING CAPACITY

Tray (600x400)mm	2
Pizza diameter 300mm	6
Pizza diameter 450mm	2

SHIPPING INFORMATION

Packed in wooden crate	
Height	900mm
Depth	1851mm
Width	1220mm
Weight	(222+50)kg
When combined with leavening compartment or stand:	
Max height	1850mm
Max weight	(305+60)kg

FEEDING AND POWER

<i>Standard feeding</i>	
A.C. V400 3N	
<i>Feeding on request</i>	
A.C. V230 3	
Frequency	50/60Hz
Max power	7,1kW
*Average power cons	3,6kWh
Connecting cable for each chamber	
type H07RN-F	
5x4mm ² (V400 3N)	
4x6mm ² (V230 3)	
Power supply (optional prover)	
A.C. V230 1N 50/60 Hz	
Max power	1,5kW
*Average power cons	0,8kWh
Conn. Cable type H07RN-F 3x1,5mm ²	

* This value is subject to variation according to the way in which the equipment is used

NOTE: MORETTI FORNI S.P.A. reserves the right to modify the characteristics of the products illustrated in this publication without prior notice

2 baking chambers height 18cm
(assembled with prover height 800mm)

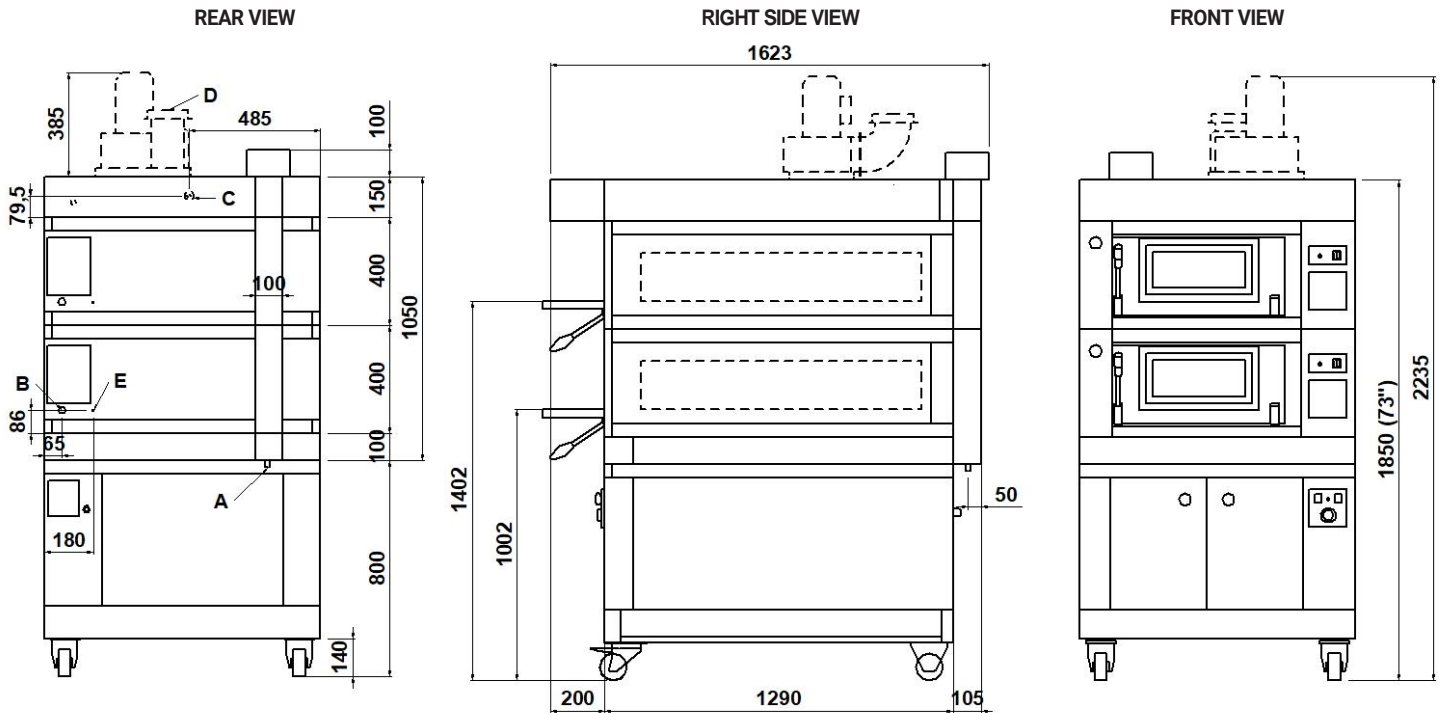

NOTE: The dimensions indicated in the views are in millimeters.

A Ø12 condensate exhaust	B fairleads	C Ø16 Hood condensate exhaust	D Ø150 steam exhaust
E M6 equipotential screws			

DIMENSIONS

External height	1050mm
External depth	1290mm
External width	1020mm
Weight	378kg

TOTAL BAKING CAPACITY

Tray (600x400)mm	4
Pizza diameter 300mm	12
Pizza diameter 450mm	4

SHIPPING INFORMATION

Packed in wooden crate	
Height	1300mm
Depth	1851mm
Width	1220mm
Weight	(378+60)kg

When combined with leavening compartment or stand:	
Max height	2250mm
Max weight	(461+70)kg

FEEDING AND POWER

<i>Standard feeding</i>	
A.C. V400 3N	
<i>Feeding on request</i>	
A.C. V230 3	
Frequency	50/60Hz
Max power	14,2kW
*Average power cons	7,1kWh
Connecting cable for each chamber	
type H07RN-F	
5x4mm ² (V400 3N)	
4x6mm ² (V230 3)	
Power supply (optional prover)	
A.C. V230 1N 50/60 Hz	
Max power	1,5kW
*Average power cons	0,8kWh
Conn. Cable type H07RN-F 3x1,5mm ²	

* This value is subject to variation according to the way in which the equipment is used

NOTE: MORETTI FORNI S.P.A. reserves the right to modify the characteristics of the products illustrated in this publication without prior notice

3 baking chambers height 18cm
(assembled with prover height 600mm)

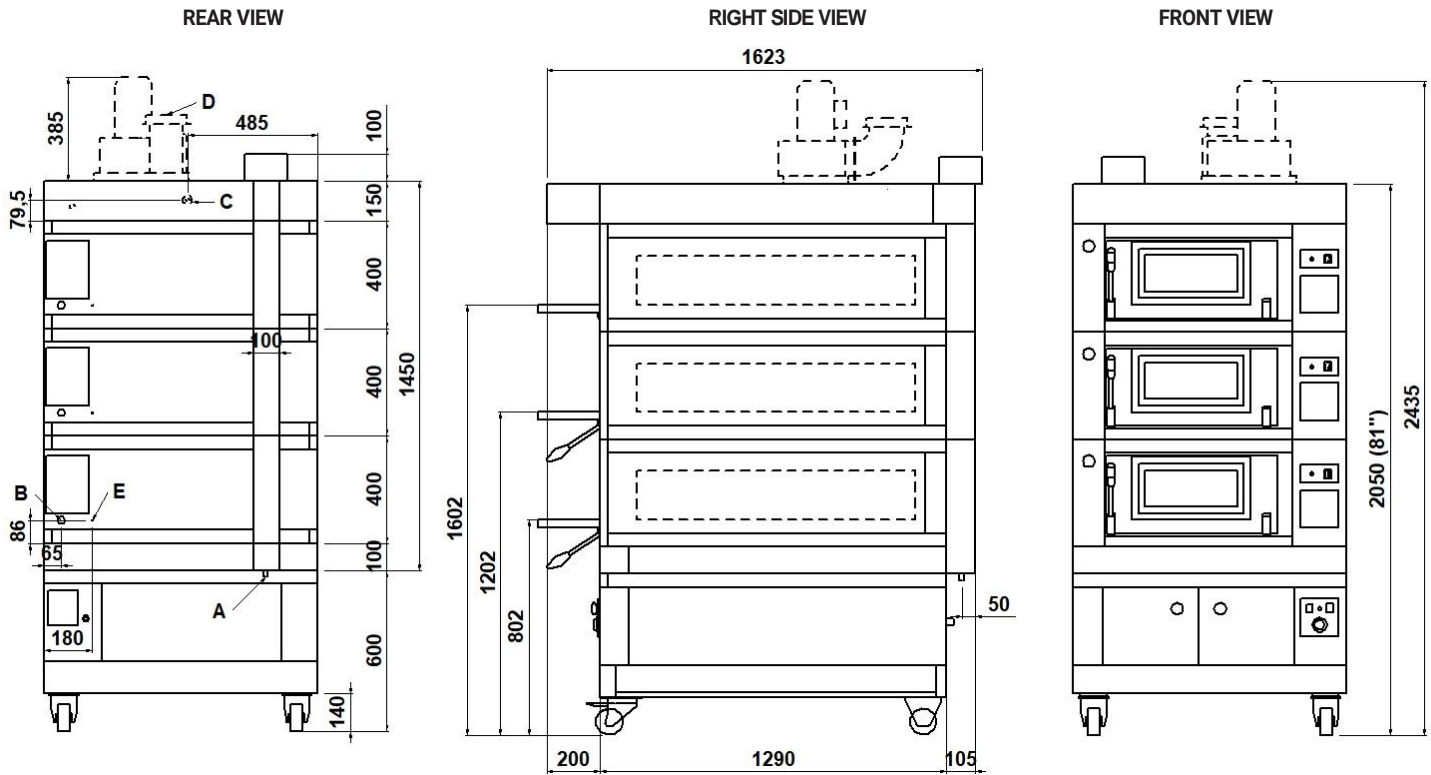

NOTE: The dimensions indicated in the views are in millimeters.

A Ø12 condensate exhaust	B fairleads	C Ø16 Hood condensate exhaust	D Ø150 steam exhaust
E M6 equipotential screws			

DIMENSIONS

External height	1450mm
External depth	1290mm
External width	1020mm
Weight	534kg

SHIPPING INFORMATION

Packed in wooden crate	
Height	1800mm
Depth	1851mm
Width	1220mm
Weight	(534+70)kg

FEEDING AND POWER

<i>Standard feeding</i>	
A.C. V400 3N	
<i>Feeding on request</i>	
A.C. V230 3	
Frequency	50/60Hz
Max power	21,3kW
*Average power cons	10,6kWh
Connecting cable for each chamber	
type H07RN-F	
5x4mm ² (V400 3N)	
4x6mm ² (V230 3)	
Power supply (optional prover)	
A.C. V230 1N 50/60 Hz	
Max power	1,5kW
*Average power cons	0,8kWh
Conn. Cable type H07RN-F 3x1,5mm ²	

TOTAL BAKING CAPACITY

Tray (600x400)mm	6	When combined with leavening compartment or stand:	
Pizza diameter 300mm	18		
Pizza diameter 450mm	6		
		Max height	2750mm
		Max weight	(617+80)kg

* This value is subject to variation according to the way in which the equipment is used

NOTE: MORETTI FORNI S.P.A. reserves the right to modify the characteristics of the products illustrated in this publication without prior notice

Amalfi A
TECHNICAL DATA

FEEDING AND POWER (REFERRED TO 1 BAKING CHAMBER)	Max power	Standard	kW	7,1
	*Average power consumption		kWh	3,6
	Max power	Boosted heating elements	kW	9,6
	*Average power consumption		kWh	4,8

TECHNICAL DATA
ONLY FOR UL MODEL

FEEDING AND POWER (EACH DECK NEEDS TO BE CONNECTED INDEPENDENTLY AND THE LOAD SHOWN BELOW ARE PER DECK)	A.C. V240 3ph 60Hz	Standard feeding	Max power	kW	7,7
			*Medium cons/hour	kWh	3,8
			Ampère Max	A/DECK	18,5
			Connecting cable	AWG/DECK	9
	A.C. V208 3ph 60Hz	Feeding on request	Max power	kW	7,7
			*Medium cons/hour	kWh	3,8
			Ampère Max	A	21,7
			Connecting cable	AWG/DECK	9
	A.C. V240 3ph 60Hz boosted heating elements	Standard feeding	Max power	kW	10,5
			*Medium cons/hour	kWh	5,3
			Ampère Max	A/DECK	25,2
			Connecting cable	AWG/DECK	9
	A.C. V208 3ph 60Hz boosted heating elements	Feeding on request	Max power	kW	10,5
			*Medium cons/hour	kWh	5,3
			Ampère Max	A/DECK	29,1
			Connecting cable	AWG/DECK	9
A.C. V(208/240) 1ph 60Hz	Proofer	Max power	kW	1,8	
		*Medium cons/hour	kWh	0,9	
		Ampère Max	A/DECK	7,5	
		Connecting cable	AWG/DECK	14	

* This value is subject to variation according to the way in which the equipment is used
NOTE: MORETTI FORNI S.P.A. reserves the right to modify the characteristics of the products illustrated in this publication without prior notice



Modular electric deck oven

2 decks composition

Amalfi consists of one or more independent baking chambers and an optional proofer or stand. The baking chamber is entirely made of refractory stone with coiled heating elements inside, allowing the perfect heat distribution over the whole surface. This oven is particularly suitable for direct pizza baking, specific for more delicate toppings and recommended for indirect baking on trays. Temperature management is electronic, power control of ceiling and floor is independent. The oven door is hinged at the bottom, with a tempered glass window to check the product during baking. The stand consists of a painted metal structure, while the proofer is a stainless steel cabinet equipped with a heating thermostat. The proofer can reach the maximum temperature of 65°C(149°F), whereas the maximum temperature of the baking chamber is 450°C (842°F).



OPERATION

- Heated by spiral heating elements
- Electronic temperature management with independent adjustment of ceiling and floor
- Maximum temperature reached 450°C (842°F)
- Continuous temperatures monitoring in baking chamber by thermocouple
- Vapour ducting using manual butterfly valve

CONSTRUCTION

- Structure made in folded stainless steel
- Side panels in painted sheet metal
- Hood in stainless steel
- Steam duct in stainless steel plate
- Stainless steel door, tempered glass
- Refractory top and side structure
- Dual halogen lighting
- Rock wool heat insulation

ACCESSORIES

- Leavening proofer on wheels height 600, 800mm
- Stand with wheels height 600, 800, 950mm
- Spacer element height 300mm
- Additional tray holder guides for compartment and Stand
- Motor for hood vapours extraction 500 m3/h
- Self-condensing hood
- Frontless hood

INTERNAL BAKING DIMENSIONS

Internal height	180mm
Internal depth	740mm
Internal width	950mm
Baking surface	0,7m ²

- Timer
- Economiser
- Independent maximum temperature safety device

TOP VIEW

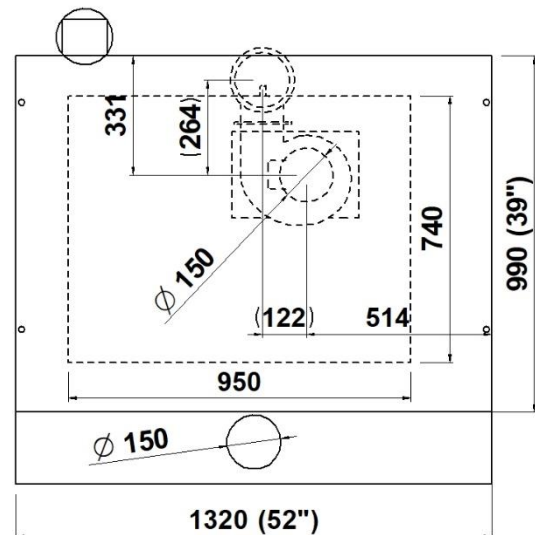

STANDARD EQUIPMENT

- 20 customisable programs

1 baking chamber height 18cm
(assembled with stand height 950mm)

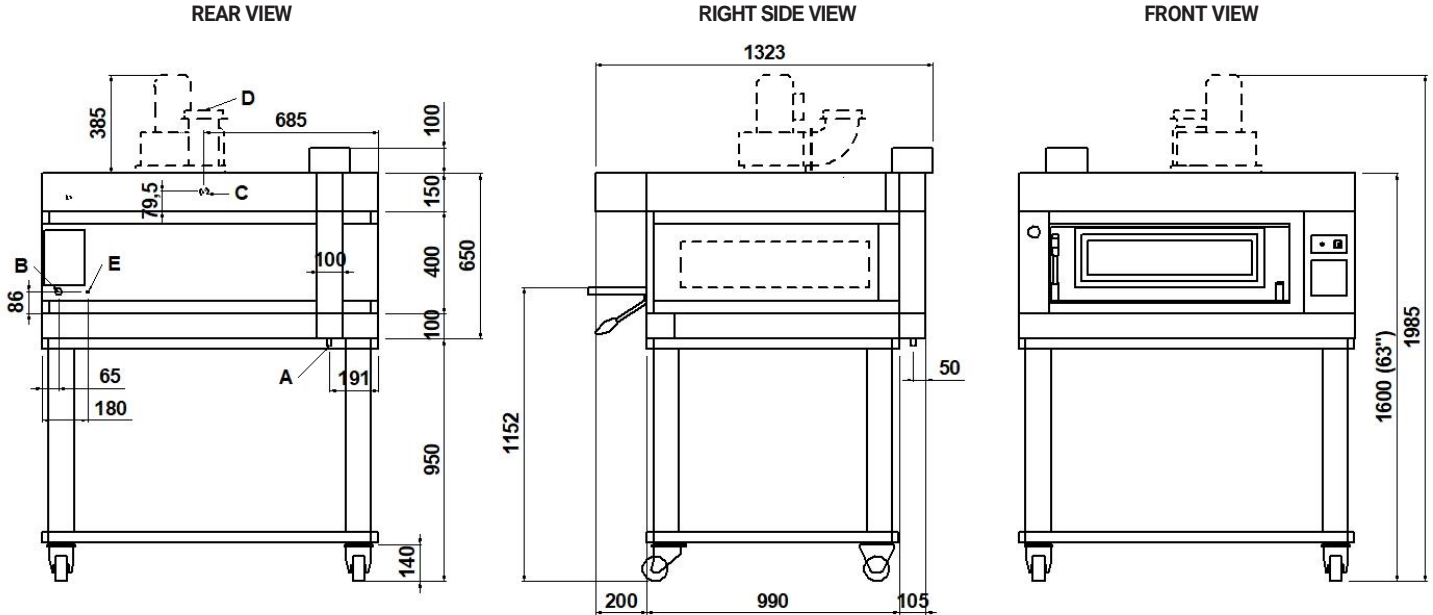

NOTE: The dimensions indicated in the views are in millimeters.

A Ø12 condensate exhaust	B fairleads	C Ø16 hood condensate exhaust	D Ø150 steam exhaust
E M6 equipotential screws			

DIMENSIONS

External height	650mm
External depth	990mm
External width	1320mm
Weight	224kg

SHIPPING INFORMATION

Packed in wooden crate	
Height	900mm
Depth	1551mm
Width	1520mm
Weight	(224+50)kg

FEEDING AND POWER

<i>Standard feeding</i>	
A.C. V400 3N	
<i>Feeding on request</i>	
A.C. V230 3	
Frequency	50/60Hz
Max power	7,1kW
*Average power cons	3,6kWh
Connecting cable for each chamber	
type H07RN-F	
5x4mm ² (V400 3N)	
4x6mm ² (V230 3)	
Power supply (optional prover)	
A.C. V230 1N 50/60 Hz	
Max power	1,5kW
*Average power cons	0,8kWh
Conn. Cable type H07RN-F 3x1,5mm ²	

TOTAL BAKING CAPACITY

Tray (600x400)mm	2	When combined with leavening compartment or Stand:
Pizza diameter 300mm	6	Max height
Pizza diameter 450mm	2	Max weight
		(317+60)kg

* This value is subject to variation according to the way in which the equipment is used
NOTE: MORETTI FORNI S.P.A. reserves the right to modify the characteristics of the products illustrated in this publication without prior notice

2 baking chambers height 18cm

(assembled with prover height 800mm)

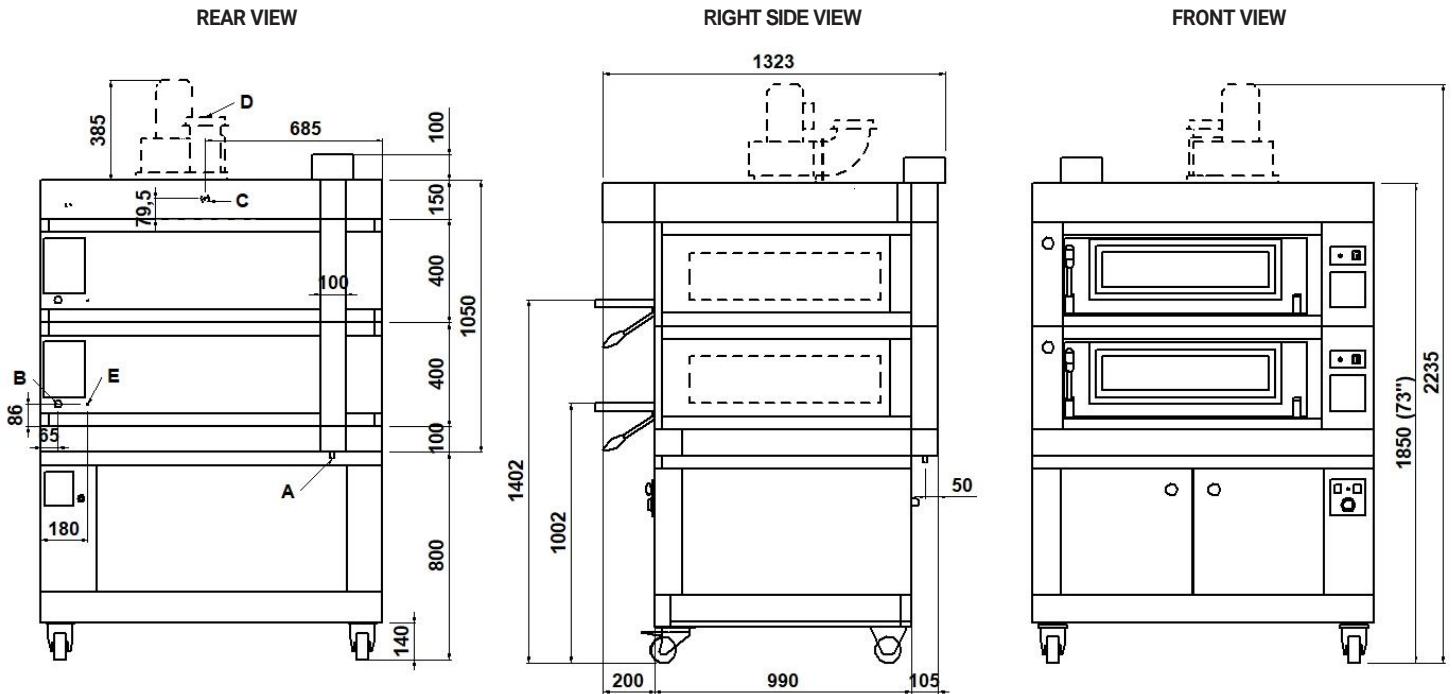

NOTE: The dimensions indicated in the views are in millimeters.

A Ø12 condensate exhaust	B fairleads	C Ø16 Hood condensate exhaust	D Ø150 steam exhaust
E M6 equipotential screws			

DIMENSIONS

External height	1050mm
External depth	990mm
External width	1320mm
Weight	379kg

SHIPPING INFORMATION

Packed in wooden crate	
Height	1300mm
Depth	1551mm
Width	1520mm
Weight	(379+60)kg

FEEDING AND POWER

<i>Standard feeding</i>	
A.C. V400 3N	
<i>Feeding on request</i>	
A.C. V230 3	
Frequency	50/60Hz
Max power	14,2kW
*Average power cons	7,1kW
Connecting cable for each chamber	
type H07RN-F	
5x4mm ² (V400 3N)	
4x6mm ² (V230 3)	
Power supply (optional prover)	
A.C. V230 1N 50/60 Hz	
Max power	1,5kW
*Average power cons	0,8kWh
Conn. Cable type H07RN-F 3x1,5mm ²	

TOTAL BAKING CAPACITY

Tray (600x400)mm	4	When combined with leavening compartment or Stand:
Pizza diameter 300mm	12	Max height
Pizza diameter 450mm	4	Max weight

* This value is subject to variation according to the way in which the equipment is used

NOTE: MORETTI FORNI S.P.A. reserves the right to modify the characteristics of the products illustrated in this publication without prior notice

3 baking chambers height 18cm
(assembled with prover height 600mm)

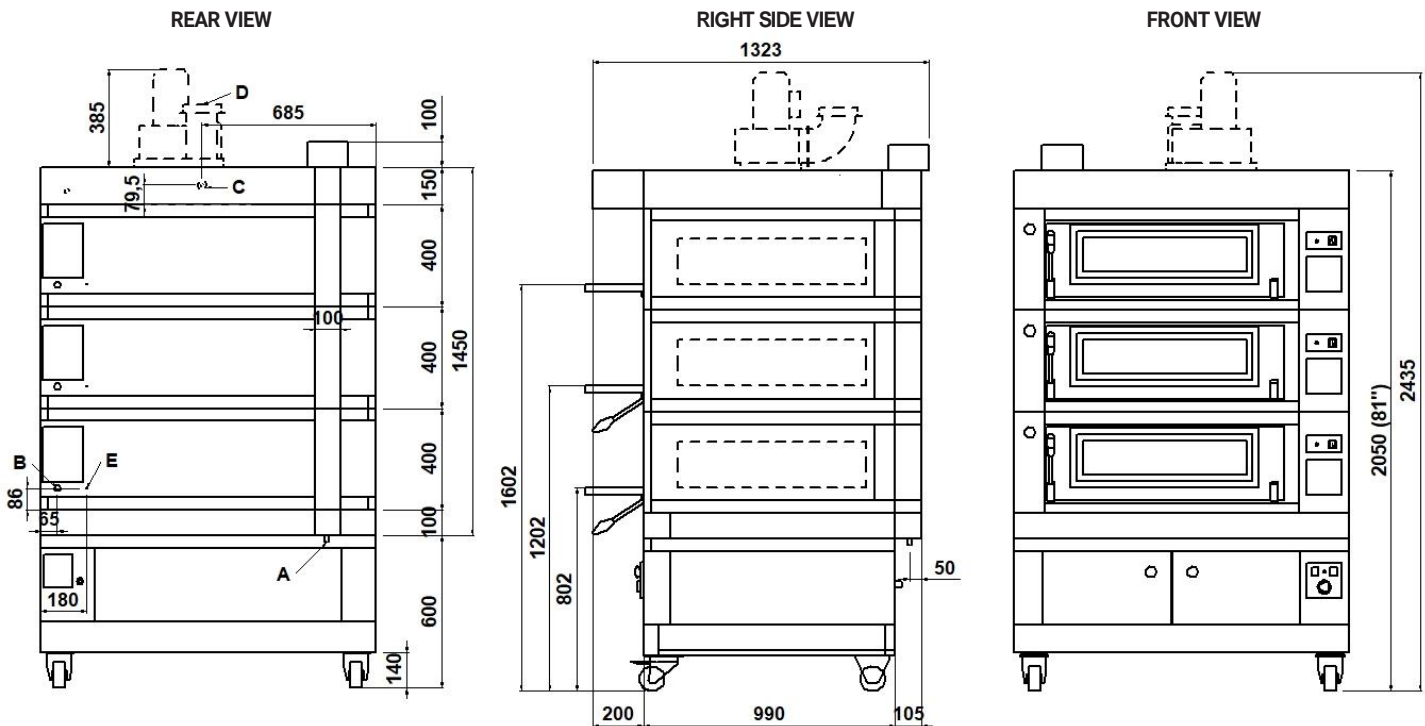

NOTE: The dimensions indicated in the views are in millimeters.

A Ø12 condensate exhaust	B fairleads	C Ø16 Hood condensate exhaust	D Ø150 steam exhaust
E M6 equipotential screws			

DIMENSIONS

External height	1450mm
External depth	990mm
External width	1320mm
Weight	534kg

TOTAL BAKING CAPACITY

Tray (600x400)mm	6
Pizza diameter 300mm	18
Pizza diameter 450mm	6

SHIPPING INFORMATION

Packed in wooden crate	
Height	1800mm
Depth	1551mm
Width	1520mm
Weight	(534+70)kg

When combined with leavening compartment or Stand:	
Max height	2750mm
Max weight	(627+80)kg

FEEDING AND POWER

<i>Standard feeding</i>	
A.C. V400 3N	
<i>Feeding on request</i>	
A.C. V230 3	
Frequency	50/60Hz
Max power	21,3kW
*Average power cons	10,6kWh
Connecting cable for each chamber	
type H07RN-F	
5x4mm ² (V400 3N)	
4x6mm ² (V230 3)	
Power supply (optional prover)	
A.C. V230 1N 50/60 Hz	
Max power	1,5kW
*Average power cons	0,8kWh
Conn. Cable type H07RN-F 3x1,5mm ²	

* This value is subject to variation according to the way in which the equipment is used

NOTE: MORETTI FORNI S.P.A. reserves the right to modify the characteristics of the products illustrated in this publication without prior notice

Amalfi B
TECHNICAL DATA

FEEDING AND POWER (REFERRED TO 1 BAKING CHAMBER)	Max power	Standard	kW	7,1
	*Average power consumption		kWh	3,6
	Max power	Boosted heating elements	kW	9,6
	*Average power consumption		kWh	4,8

TECHNICAL DATA
ONLY FOR UL MODEL

FEEDING AND POWER (EACH DECK NEEDS TO BE CONNECTED INDEPENDENTLY AND THE LOAD SHOWN BELOW ARE PER DECK)	A.C. V240 3ph 60Hz	Standard feeding	Max power	kW	7,7
			*Medium cons/hour	kWh	3,8
			Ampère Max	A/DECK	18,5
			Connecting cable	AWG/DECK	9
	A.C. V208 3ph 60Hz	Feeding on request	Max power	kW	7,7
			*Medium cons/hour	kWh	3,8
			Ampère Max	A	21,7
			Connecting cable	AWG/DECK	9
	A.C. V240 3ph 60Hz boosted heating elements	Standard feeding	Max power	kW	10,5
			*Medium cons/hour	kWh	5,3
			Ampère Max	A/DECK	25,2
			Connecting cable	AWG/DECK	9
	A.C. V208 3ph 60Hz boosted heating elements	Feeding on request	Max power	kW	10,5
			*Medium cons/hour	kWh	5,3
			Ampère Max	A/DECK	29,1
			Connecting cable	AWG/DECK	9
A.C. V(208/240) 1ph 60Hz	Proofer	Max power	kW	1,8	
		*Medium cons/hour	kWh	0,9	
		Ampère Max	A/DECK	7,5	
		Connecting cable	AWG/DECK	14	

* This value is subject to variation according to the way in which the equipment is used
NOTE: MORETTI FORNI S.P.A. reserves the right to modify the characteristics of the products illustrated in this publication without prior notice



Modular electric deck oven

2 decks composition

Amalfi consists of one or more independent baking chambers and an optional proofer or stand. The baking chamber is entirely made of refractory stone with coiled heating elements inside, allowing the perfect heat distribution over the whole surface. This oven is particularly suitable for direct pizza baking, specific for more delicate toppings and recommended for indirect baking on trays. Temperature management is electronic, power control of ceiling and floor is independent. The oven door is hinged at the bottom, with a tempered glass window to check the product during baking. The stand consists of a painted metal structure, while the proofer is a stainless steel cabinet equipped with a heating thermostat. The proofer can reach the maximum temperature of 65°C(149°F), whereas the maximum temperature of the baking chamber is 450°C (842°F).



OPERATION

- Heated by spiral heating elements
- Electronic temperature management with independent adjustment of ceiling and floor
- Maximum temperature reached 450°C (842°F)
- Continuous temperatures monitoring in baking chamber by thermocouple
- Vapour ducting using manual butterfly valve

CONSTRUCTION

- Structure made in folded stainless steel
- Side panels in painted sheet metal
- Hood in stainless steel
- Steam duct in stainless steel plate
- Stainless steel door, tempered glass
- Refractory top and side structure
- Dual halogen lighting
- Rock wool heat insulation

ACCESSORIES

- Leavening proofer on wheels height 600, 800mm
- Stand with wheels height 600, 800, 950mm
- Spacer element height 300mm
- Additional tray holder guides for compartment and Stand
- Motor for hood vapours extraction 500 m3/h
- Self-condensing hood
- Frontless hood

INTERNAL BAKING DIMENSIONS

Internal height	180mm
Internal depth	740mm
Internal width	950mm
Baking surface	0,7m ²

- Timer
- Economiser
- Independent maximum temperature safety device

TOP VIEW

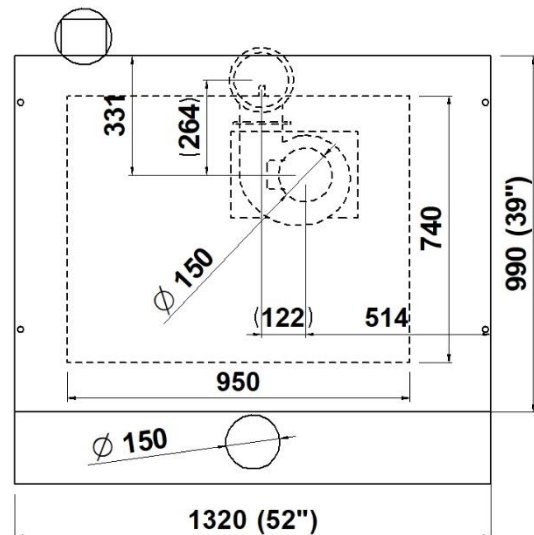

STANDARD EQUIPMENT

- 20 customisable programs

1 baking chamber height 18cm
(assembled with stand height 950mm)

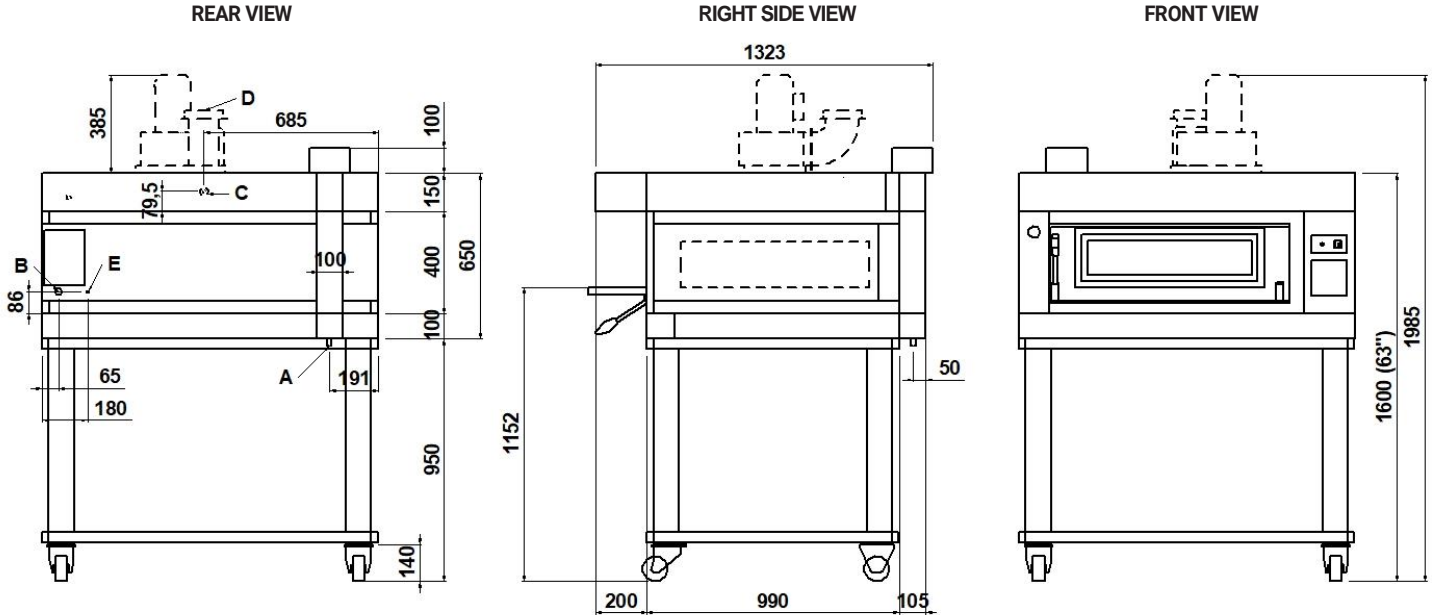

NOTE: The dimensions indicated in the views are in millimeters.

A Ø12 condensate exhaust	B fairleads	C Ø16 hood condensate exhaust	D Ø150 steam exhaust
E M6 equipotential screws			

DIMENSIONS

External height	650mm
External depth	990mm
External width	1320mm
Weight	224kg

TOTAL BAKING CAPACITY

Tray (600x400)mm	2
Pizza diameter 300mm	6
Pizza diameter 450mm	2

SHIPPING INFORMATION

Packed in wooden crate	
Height	900mm
Depth	1551mm
Width	1520mm
Weight	(224+50)kg

When combined with leavening compartment or Stand:	
Max height	1850mm
Max weight	(317+60)kg

FEEDING AND POWER

<i>Standard feeding</i>	
A.C. V400 3N	
<i>Feeding on request</i>	
A.C. V230 3	
Frequency	50/60Hz
Max power	7,1kW
*Average power cons	3,6kWh
Connecting cable for each chamber	
type H07RN-F	
5x4mm ² (V400 3N)	
4x6mm ² (V230 3)	
Power supply (optional prover)	
A.C. V230 1N 50/60 Hz	
Max power	1,5kW
*Average power cons	0,8kWh
Conn. Cable type H07RN-F 3x1,5mm ²	

* This value is subject to variation according to the way in which the equipment is used
NOTE: MORETTI FORNI S.P.A. reserves the right to modify the characteristics of the products illustrated in this publication without prior notice

2 baking chambers height 18cm

(assembled with prover height 800mm)

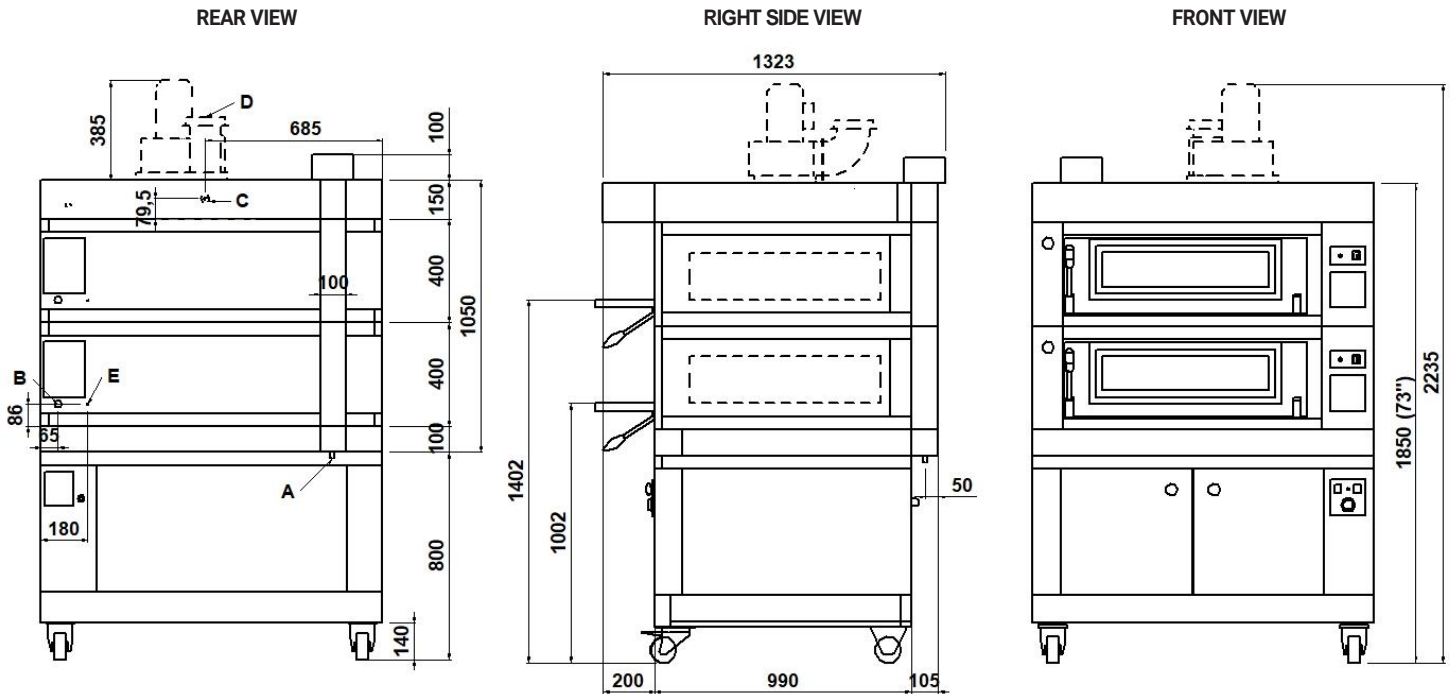

NOTE: The dimensions indicated in the views are in millimeters.

A Ø12 condensate exhaust	B fairleads	C Ø16 Hood condensate exhaust	D Ø150 steam exhaust
E M6 equipotential screws			

DIMENSIONS

External height	1050mm
External depth	990mm
External width	1320mm
Weight	379kg

SHIPPING INFORMATION

Packed in wooden crate	
Height	1300mm
Depth	1551mm
Width	1520mm
Weight	(379+60)kg

FEEDING AND POWER

<i>Standard feeding</i>	
A.C. V400 3N	
<i>Feeding on request</i>	
A.C. V230 3	
Frequency	50/60Hz
Max power	14,2kW
*Average power cons	7,1kW
Connecting cable for each chamber	
type H07RN-F	
5x4mm ² (V400 3N)	
4x6mm ² (V230 3)	
Power supply (optional prover)	
A.C. V230 1N 50/60 Hz	
Max power	1,5kW
*Average power cons	0,8kWh
Conn. Cable type H07RN-F 3x1,5mm ²	

TOTAL BAKING CAPACITY

Tray (600x400)mm	4
Pizza diameter 300mm	12
Pizza diameter 450mm	4

When combined with leavening compartment or Stand:	
Max height	2250mm
Max weight	(472+70)kg

* This value is subject to variation according to the way in which the equipment is used

NOTE: MORETTI FORNI S.P.A. reserves the right to modify the characteristics of the products illustrated in this publication without prior notice

3 baking chambers height 18cm
(assembled with prover height 600mm)

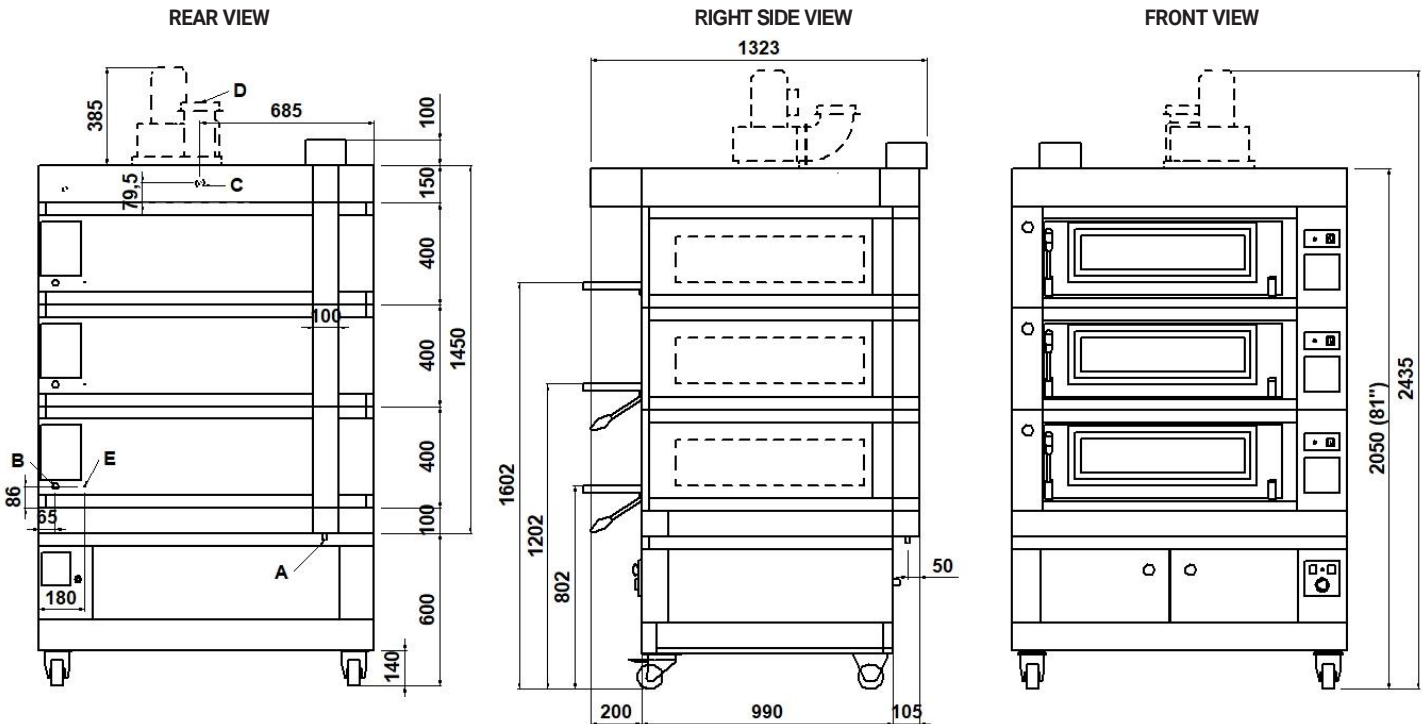

NOTE: The dimensions indicated in the views are in millimeters.

A Ø12 condensate exhaust	B fairleads	C Ø16 Hood condensate exhaust	D Ø150 steam exhaust
E M6 equipotential screws			

DIMENSIONS

External height	1450mm
External depth	990mm
External width	1320mm
Weight	534kg

TOTAL BAKING CAPACITY

Tray (600x400)mm	6
Pizza diameter 300mm	18
Pizza diameter 450mm	6

SHIPPING INFORMATION

Packed in wooden crate	
Height	1800mm
Depth	1551mm
Width	1520mm
Weight	(534+70)kg

When combined with leavening compartment or Stand:	
Max height	2750mm
Max weight	(627+80)kg

FEEDING AND POWER

<i>Standard feeding</i>	
A.C. V400 3N	
<i>Feeding on request</i>	
A.C. V230 3	
Frequency	50/60Hz
Max power	21,3kW
*Average power cons	10,6kWh
Connecting cable for each chamber	
type H07RN-F	
5x4mm ² (V400 3N)	
4x6mm ² (V230 3)	
Power supply (optional prover)	
A.C. V230 1N 50/60 Hz	
Max power	1,5kW
*Average power cons	0,8kWh
Conn. Cable type H07RN-F 3x1,5mm ²	

* This value is subject to variation according to the way in which the equipment is used

NOTE: MORETTI FORNI S.P.A. reserves the right to modify the characteristics of the products illustrated in this publication without prior notice

Amalfi B
TECHNICAL DATA

FEEDING AND POWER (REFERRED TO 1 BAKING CHAMBER)	Max power	Standard	kW	7,1
	*Average power consumption		kWh	3,6
	Max power	Boosted heating elements	kW	9,6
	*Average power consumption		kWh	4,8

TECHNICAL DATA
ONLY FOR UL MODEL

FEEDING AND POWER (EACH DECK NEEDS TO BE CONNECTED INDEPENDENTLY AND THE LOAD SHOWN BELOW ARE PER DECK)	A.C. V240 3ph 60Hz	Standard feeding	Max power	kW	7,7
			*Medium cons/hour	kWh	3,8
			Ampère Max	A/DECK	18,5
			Connecting cable	AWG/DECK	9
	A.C. V208 3ph 60Hz	Feeding on request	Max power	kW	7,7
			*Medium cons/hour	kWh	3,8
			Ampère Max	A	21,7
			Connecting cable	AWG/DECK	9
	A.C. V240 3ph 60Hz boosted heating elements	Standard feeding	Max power	kW	10,5
			*Medium cons/hour	kWh	5,3
			Ampère Max	A/DECK	25,2
			Connecting cable	AWG/DECK	9
	A.C. V208 3ph 60Hz boosted heating elements	Feeding on request	Max power	kW	10,5
			*Medium cons/hour	kWh	5,3
			Ampère Max	A/DECK	29,1
			Connecting cable	AWG/DECK	9
A.C. V(208/240) 1ph 60Hz	Proofer	Max power	kW	1,8	
		*Medium cons/hour	kWh	0,9	
		Ampère Max	A/DECK	7,5	
		Connecting cable	AWG/DECK	14	

* This value is subject to variation according to the way in which the equipment is used
NOTE: MORETTI FORNI S.P.A. reserves the right to modify the characteristics of the products illustrated in this publication without prior notice



Modular electric deck oven

2 decks composition

Amalfi consists of one or more independent baking chambers and an optional proofer or stand. The baking chamber is entirely made of refractory stone with coiled heating elements inside, allowing the perfect heat distribution over the whole surface. This oven is particularly suitable for direct pizza baking, specific for more delicate toppings and recommended for indirect baking on trays. Temperature management is electronic, power control of ceiling and floor is independent. The oven door is hinged at the bottom, with a tempered glass window to check the product during baking. The stand consists of a painted metal structure, while the proofer is a stainless steel cabinet equipped with a heating thermostat. The proofer can reach the maximum temperature of 65°C(149°F), whereas the maximum temperature of the baking chamber is 450°C (842°F).



OPERATION

- Heated by spiral heating elements
- Electronic temperature management with independent adjustment of ceiling and floor
- Maximum temperature reached 450°C (842°F)
- Continuous temperatures monitoring in baking chamber by thermocouple
- Vapour ducting using manual butterfly valve

CONSTRUCTION

- Structure made in folded stainless steel
- Side panels in painted sheet metal
- Hood in stainless steel
- Steam duct in stainless steel plate
- Stainless steel door, tempered glass
- Refractory top and side structure
- Dual halogen lighting
- Rock wool heat insulation

ACCESSORIES

- Leavening proofer on wheels height 600, 800mm
- Stand with wheels height 600, 800, 950mm
- Spacer element height 300mm
- Additional tray holder guides for compartment and Stand
- Motor for hood vapours extraction 500 m3/h
- Self-condensing hood
- Frontless hood

INTERNAL BAKING DIMENSIONS

Internal height	180mm
Internal depth	740mm
Internal width	950mm
Baking surface	0,7m ²

- Timer
- Economiser
- Independent maximum temperature safety device

TOP VIEW

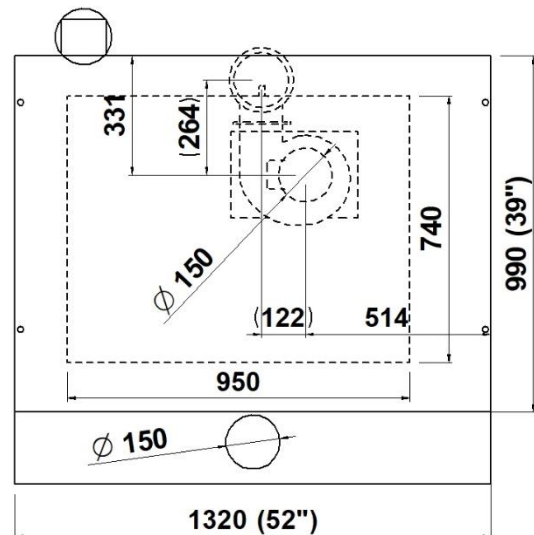

STANDARD EQUIPMENT

- 20 customisable programs

1 baking chamber height 18cm
(assembled with stand height 950mm)

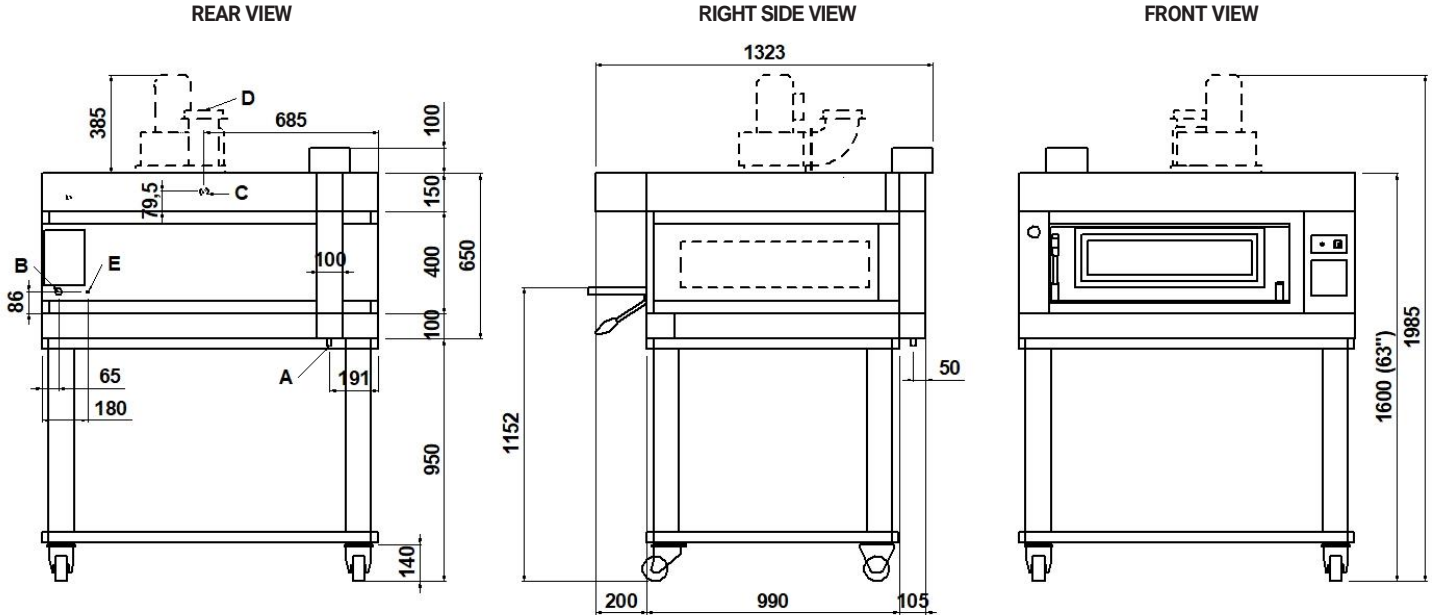

NOTE: The dimensions indicated in the views are in millimeters.

A Ø12 condensate exhaust	B fairleads	C Ø16 hood condensate exhaust	D Ø150 steam exhaust
E M6 equipotential screws			

DIMENSIONS

External height	650mm
External depth	990mm
External width	1320mm
Weight	224kg

TOTAL BAKING CAPACITY

Tray (600x400)mm	2
Pizza diameter 300mm	6
Pizza diameter 450mm	2

SHIPPING INFORMATION

Packed in wooden crate	
Height	900mm
Depth	1551mm
Width	1520mm
Weight	(224+50)kg

When combined with leavening compartment or Stand:	
Max height	1850mm
Max weight	(317+60)kg

FEEDING AND POWER

<i>Standard feeding</i>	
A.C. V400 3N	
<i>Feeding on request</i>	
A.C. V230 3	
Frequency	50/60Hz
Max power	7,1kW
*Average power cons	3,6kWh
Connecting cable for each chamber	
type H07RN-F	
5x4mm ² (V400 3N)	
4x6mm ² (V230 3)	
Power supply (optional prover)	
A.C. V230 1N 50/60 Hz	
Max power	1,5kW
*Average power cons	0,8kWh
Conn. Cable type H07RN-F 3x1,5mm ²	

* This value is subject to variation according to the way in which the equipment is used
NOTE: MORETTI FORNI S.P.A. reserves the right to modify the characteristics of the products illustrated in this publication without prior notice

2 baking chambers height 18cm

(assembled with prover height 800mm)

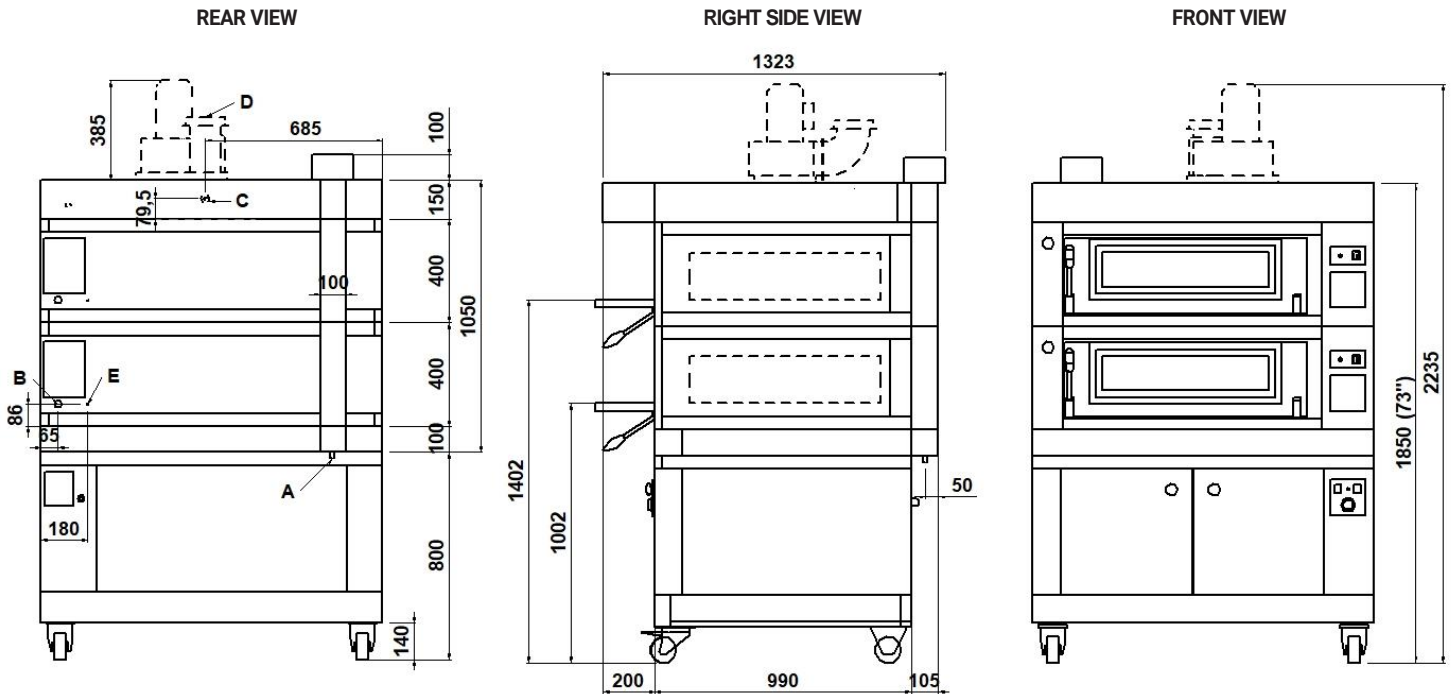

NOTE: The dimensions indicated in the views are in millimeters.

A Ø12 condensate exhaust	B fairleads	C Ø16 Hood condensate exhaust	D Ø150 steam exhaust
E M6 equipotential screws			

DIMENSIONS

External height	1050mm
External depth	990mm
External width	1320mm
Weight	379kg

SHIPPING INFORMATION

Packed in wooden crate	
Height	1300mm
Depth	1551mm
Width	1520mm
Weight	(379+60)kg

FEEDING AND POWER

<i>Standard feeding</i>	
A.C. V400 3N	
<i>Feeding on request</i>	
A.C. V230 3	
Frequency	50/60Hz
Max power	14,2kW
*Average power cons	7,1kWh
Connecting cable for each chamber	
type H07RN-F	
5x4mm ² (V400 3N)	
4x6mm ² (V230 3)	
Power supply (optional prover)	
A.C. V230 1N 50/60 Hz	
Max power	1,5kW
*Average power cons	0,8kWh
Conn. Cable type H07RN-F 3x1,5mm ²	

TOTAL BAKING CAPACITY

Tray (600x400)mm	4	When combined with leavening compartment or Stand:
Pizza diameter 300mm	12	Max height
Pizza diameter 450mm	4	Max weight

* This value is subject to variation according to the way in which the equipment is used

NOTE: MORETTI FORNI S.P.A. reserves the right to modify the characteristics of the products illustrated in this publication without prior notice

3 baking chambers height 18cm
(assembled with prover height 600mm)

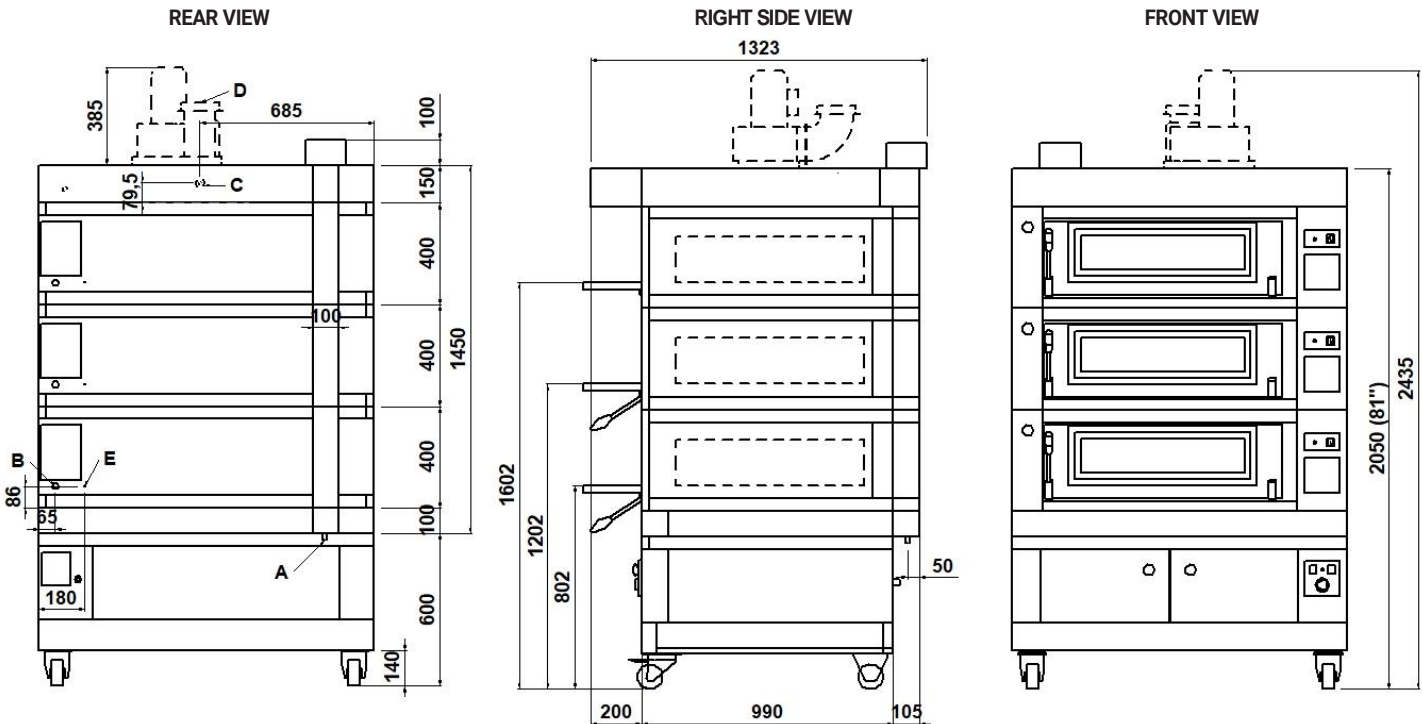

NOTE: The dimensions indicated in the views are in millimeters.

A Ø12 condensate exhaust	B fairleads	C Ø16 Hood condensate exhaust	D Ø150 steam exhaust
E M6 equipotential screws			

DIMENSIONS

External height	1450mm
External depth	990mm
External width	1320mm
Weight	534kg

TOTAL BAKING CAPACITY

Tray (600x400)mm	6
Pizza diameter 300mm	18
Pizza diameter 450mm	6

SHIPPING INFORMATION

Packed in wooden crate	
Height	1800mm
Depth	1551mm
Width	1520mm
Weight	(534+70)kg

When combined with leavening compartment or Stand:	
Max height	2750mm
Max weight	(627+80)kg

FEEDING AND POWER

<i>Standard feeding</i>	
A.C. V400 3N	
<i>Feeding on request</i>	
A.C. V230 3	
Frequency	50/60Hz
Max power	21,3kW
*Average power cons	10,6kWh
Connecting cable for each chamber	
type H07RN-F	
5x4mm ² (V400 3N)	
4x6mm ² (V230 3)	
Power supply (optional prover)	
A.C. V230 1N 50/60 Hz	
Max power	1,5kW
*Average power cons	0,8kWh
Conn. Cable type H07RN-F 3x1,5mm ²	

* This value is subject to variation according to the way in which the equipment is used

NOTE: MORETTI FORNI S.P.A. reserves the right to modify the characteristics of the products illustrated in this publication without prior notice

Amalfi B
TECHNICAL DATA

FEEDING AND POWER (REFERRED TO 1 BAKING CHAMBER)	Max power	Standard	kW	7,1
	*Average power consumption		kWh	3,6
	Max power	Boosted heating elements	kW	9,6
	*Average power consumption		kWh	4,8

TECHNICAL DATA
ONLY FOR UL MODEL

FEEDING AND POWER (EACH DECK NEEDS TO BE CONNECTED INDEPENDENTLY AND THE LOAD SHOWN BELOW ARE PER DECK)	A.C. V240 3ph 60Hz	Standard feeding	Max power	kW	7,7
			*Medium cons/hour	kWh	3,8
			Ampère Max	A/DECK	18,5
			Connecting cable	AWG/DECK	9
	A.C. V208 3ph 60Hz	Feeding on request	Max power	kW	7,7
			*Medium cons/hour	kWh	3,8
			Ampère Max	A	21,7
			Connecting cable	AWG/DECK	9
	A.C. V240 3ph 60Hz boosted heating elements	Standard feeding	Max power	kW	10,5
			*Medium cons/hour	kWh	5,3
			Ampère Max	A/DECK	25,2
			Connecting cable	AWG/DECK	9
	A.C. V208 3ph 60Hz boosted heating elements	Feeding on request	Max power	kW	10,5
			*Medium cons/hour	kWh	5,3
			Ampère Max	A/DECK	29,1
			Connecting cable	AWG/DECK	9
A.C. V(208/240) 1ph 60Hz	Proofer	Max power	kW	1,8	
		*Medium cons/hour	kWh	0,9	
		Ampère Max	A/DECK	7,5	
		Connecting cable	AWG/DECK	14	

* This value is subject to variation according to the way in which the equipment is used
NOTE: MORETTI FORNI S.P.A. reserves the right to modify the characteristics of the products illustrated in this publication without prior notice



Modular electric deck oven

2 decks composition

Amalfi consists of one or more independent baking chambers and an optional proofer or stand. The baking chamber is entirely made of refractory stone with coiled heating elements inside, allowing the perfect heat distribution over the whole surface. This oven is particularly suitable for direct pizza baking, specific for more delicate toppings and recommended for indirect baking on trays. Temperature management is electronic, power control of ceiling and floor is independent. The oven door is hinged at the bottom, with a tempered glass window to check the product during baking. The stand consists of a painted metal structure, while the proofer is a stainless steel cabinet equipped with a heating thermostat. The proofer can reach the maximum temperature of 65°C(149°F), whereas the maximum temperature of the baking chamber is 450°C (842°F).



OPERATION

- Heated by spiral heating elements
- Electronic temperature management with independent adjustment of ceiling and floor
- Maximum temperature reached 450°C (842°F)
- Continuous temperatures monitoring in baking chamber by thermocouple
- Vapour ducting using manual butterfly valve

CONSTRUCTION

- Structure made in folded stainless steel
- Side panels in painted sheet metal
- Hood in stainless steel
- Steam duct in stainless steel plate
- Stainless steel door, tempered glass
- Refractory top and side structure
- Dual halogen lighting
- Rock wool heat insulation

ACCESSORIES

- Leavening proofer on wheels height 600, 800mm
- Stand with wheels height 600, 800, 950mm
- Spacer element height 300mm
- Additional tray holder guides for compartment and Stand
- Motor for hood vapours extraction 500 m3/h
- Self-condensing hood
- Frontless hood

INTERNAL BAKING DIMENSIONS

Internal height	180mm
Internal depth	1040mm
Internal width	950mm
Baking surface	1,0m ²

- Timer
- Economiser
- Independent maximum temperature safety device

TOP VIEW

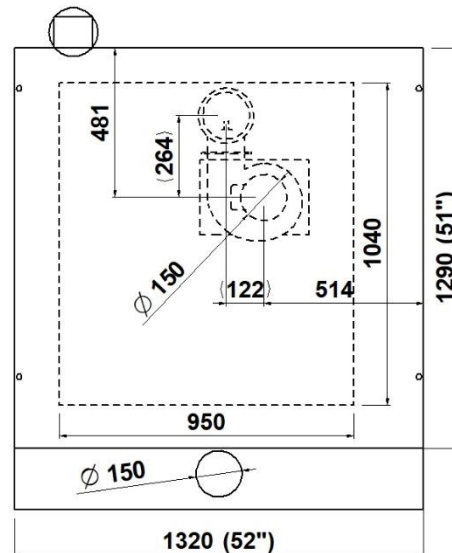

STANDARD EQUIPMENT

- 20 customisable programs

1 baking chamber height 18cm

(assembled with stand height 950mm)

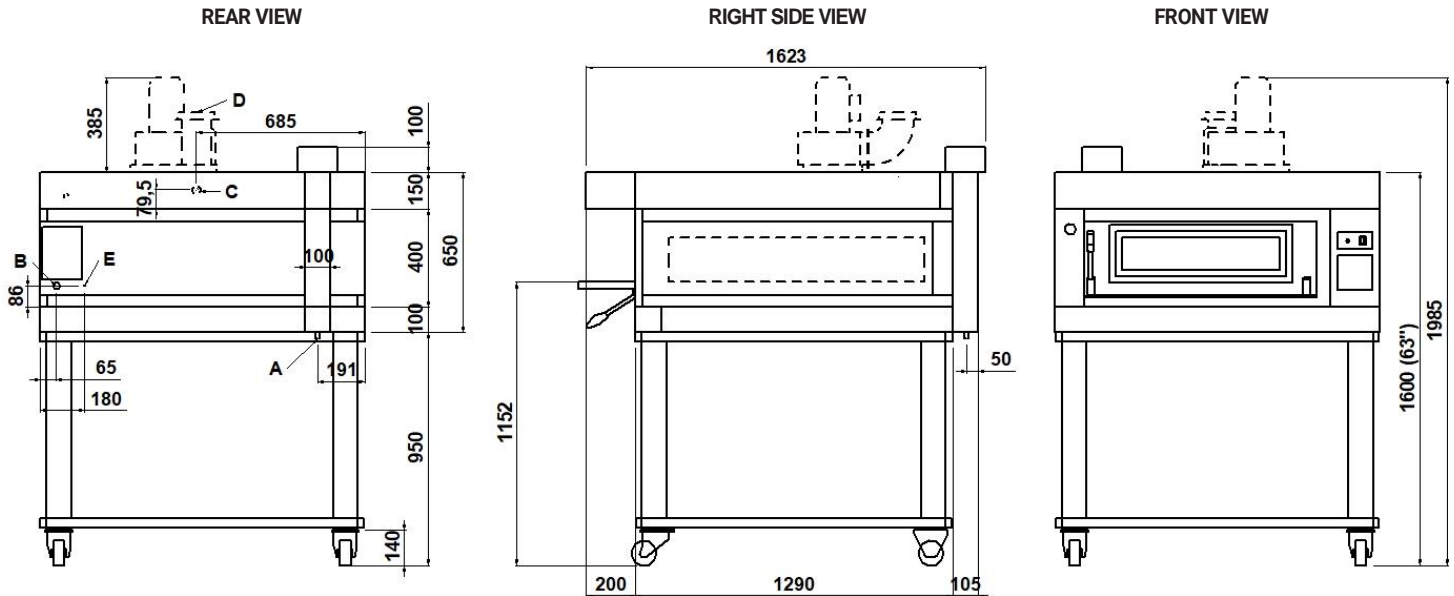

NOTE: The dimensions indicated in the views are in millimeters.

A Ø12 condensate exhaust	B fairleads	C Ø16 hood condensate exhaust	D Ø150 steam exhaust
E M6 equipotential screws			

DIMENSIONS

External height	650mm
External depth	1290mm
External width	1320mm
Weight	273kg

TOTAL BAKING CAPACITY

Tray (600x400)mm	3
Pizza diameter 300mm	9
Pizza diameter 450mm	4

SHIPPING INFORMATION

Packed in wooden crate	
Height	900mm
Depth	1851mm
Width	1520mm
Weight	(273+50)kg
When combined with leavening compartment or Stand:	
Max height	1850mm
Max weight	(381+60)kg

FEEDING AND POWER

<i>Standard feeding</i>	
A.C. V400 3N	
<i>Feeding on request</i>	
A.C. V230 3	
Frequency	50/60Hz
Max power	9,6kW
*Average power cons	4,8kWh
Connecting cable for each chamber	
type H07RN-F	
5x4mm ² (V400 3N)	
4x6mm ² (V230 3)	
Power supply (optional prover)	
A.C. V230 1N 50/60 Hz	
Max power	1,5kW
*Average power cons	0,8kWh
Conn. Cable type H07RN-F 3x1,5mm ²	

* This value is subject to variation according to the way in which the equipment is used

NOTE: MORETTI FORNI S.P.A. reserves the right to modify the characteristics of the products illustrated in this publication without prior notice

2 baking chambers height 18cm

(assembled with prover height 800mm)

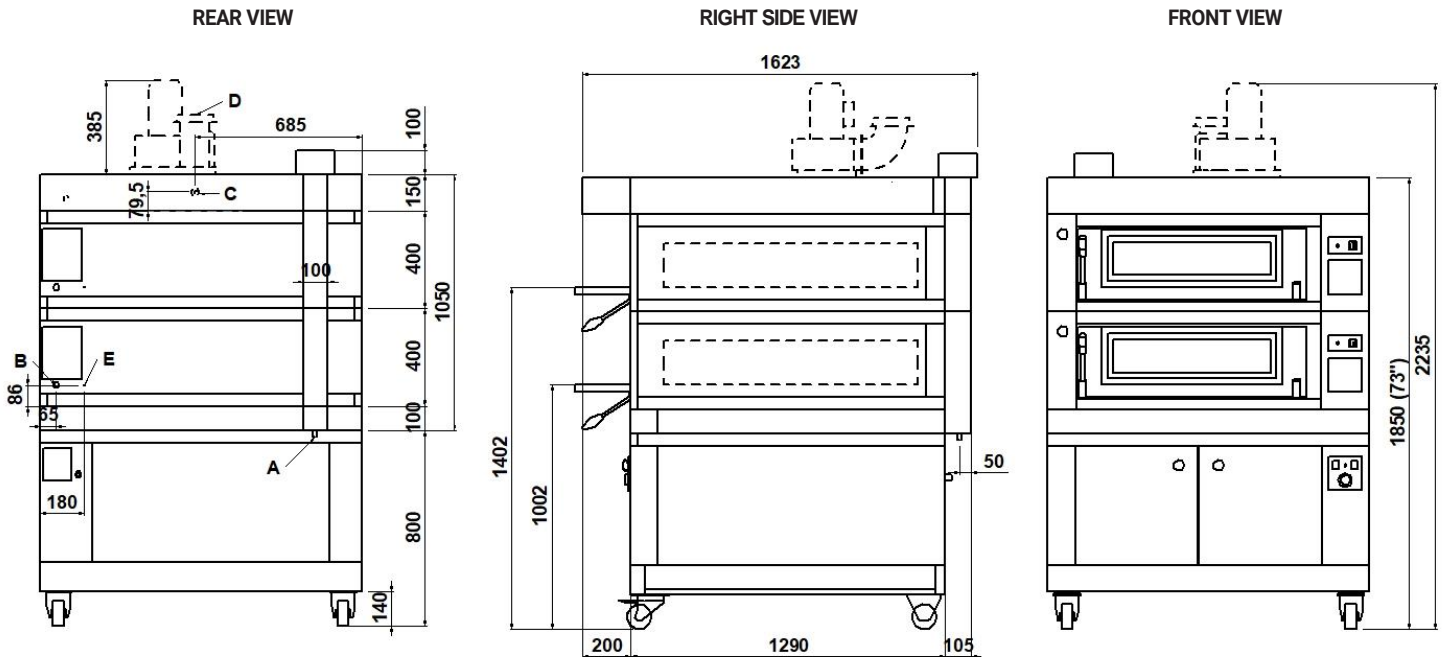

NOTE: The dimensions indicated in the views are in millimeters.

A Ø12 condensate exhaust	B fairleads	C Ø16 Hood condensate exhaust	D Ø150 steam exhaust
E M6 equipotential screws			

DIMENSIONS

External height	1050mm
External depth	1290mm
External width	1320mm
Weight	466kg

SHIPPING INFORMATION

Packed in wooden crate	
Height	1300mm
Depth	1851mm
Width	1520mm
Weight	(466+60)kg

FEEDING AND POWER

<i>Standard feeding</i>	
A.C. V400 3N	
<i>Feeding on request</i>	
A.C. V230 3	
Frequency	50/60Hz
Max power	19,2kW
*Average power cons	9,6kWh
Connecting cable for each chamber	
type H07RN-F	
5x4mm ² (V400 3N)	
4x6mm ² (V230 3)	
Power supply (optional prover)	
A.C. V230 1N 50/60 Hz	
Max power	1,5kW
*Average power cons	0,8kWh
Conn. Cable type H07RN-F	3x1,5mm ²

TOTAL BAKING CAPACITY

Tray (600x400)mm	6	When combined with leavening
Pizza diameter 300mm	18	compartment or Stand:
Pizza diameter 450mm	6	Max height
		2250mm
		Max weight
		(574+70)kg

* This value is subject to variation according to the way in which the equipment is used

NOTE: MORETTI FORNI S.P.A. reserves the right to modify the characteristics of the products illustrated in this publication without prior notice

3 baking chambers height 18cm

(assembled with prover height 600mm)

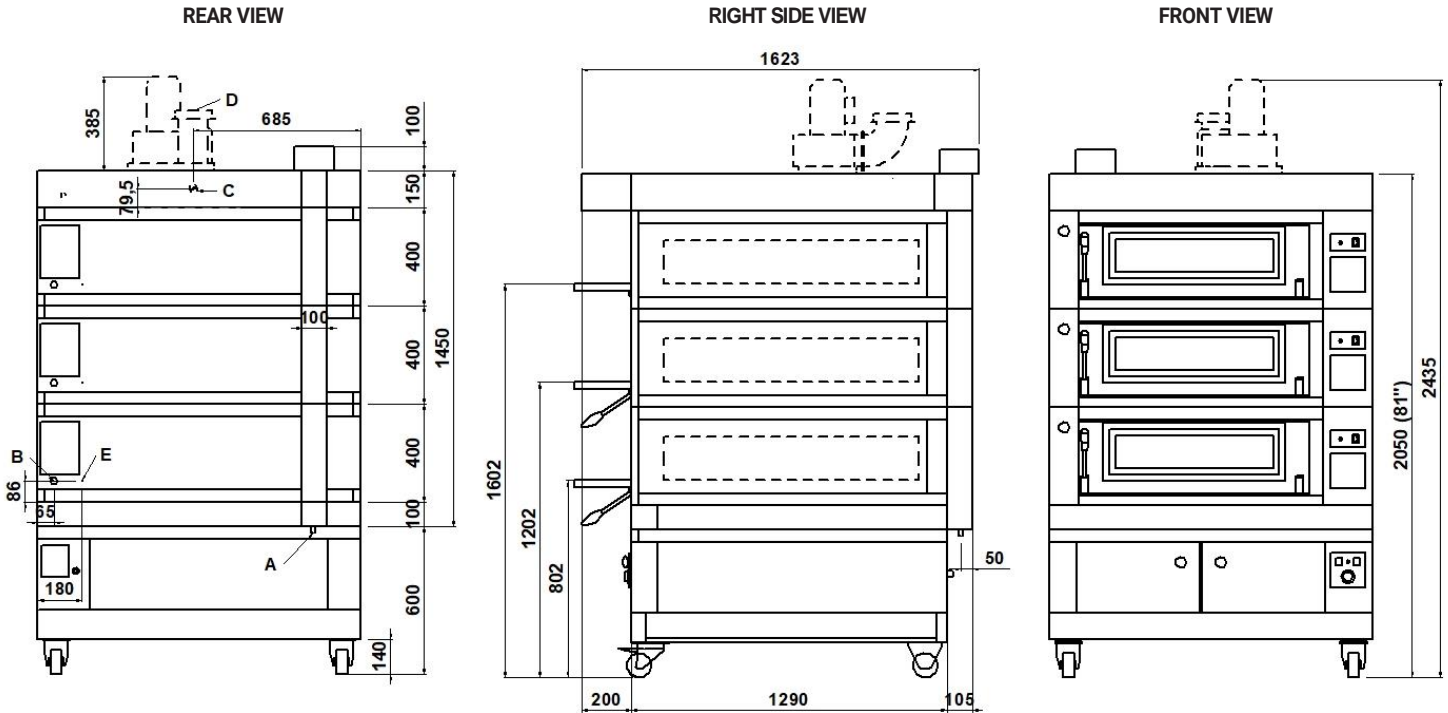

NOTE: The dimensions indicated in the views are in millimeters.

A Ø12 condensate exhaust	B fairleads	C Ø16 Hood condensate exhaust	D Ø150 steam exhaust
E M6 equipotential screws			

DIMENSIONS

External height	1450mm
External depth	1290mm
External width	1320mm
Weight	659kg

SHIPPING INFORMATION

Packed in wooden crate	
Height	1800mm
Depth	1851mm
Width	1520mm
Weight	(659+70)kg

FEEDING AND POWER

<i>Standard feeding</i>	
A.C. V400 3N	
<i>Feeding on request</i>	
A.C. V230 3	
Frequency	50/60Hz
Max power	28,8kW
*Average power cons	14,4kWh
Connecting cable for each chamber	
type H07RN-F	
5x4mm ² (V400 3N)	
4x6mm ² (V230 3)	
Power supply (optional prover)	
A.C. V230 1N 50/60 Hz	
Max power	1,5kW
*Average power cons	0,8kWh
Conn. Cable type H07RN-F 3x1,5mm ²	

TOTAL BAKING CAPACITY

Tray (600x400)mm	9	When combined with leavening compartment or Stand:
Pizza diameter 300mm	27	Max height
Pizza diameter 450mm	12	Max weight

* This value is subject to variation according to the way in which the equipment is used

NOTE: MORETTI FORNI S.P.A. reserves the right to modify the characteristics of the products illustrated in this publication without prior notice

Amalfi C
TECHNICAL DATA

FEEDING AND POWER (REFERRED TO 1 BAKING CHAMBER)	Max power	Standard	kW	9,6
	*Average power consumption		kWh	4,8
	Max power	Boosted heating elements	kW	11,1
	*Average power consumption		kWh	5,6

TECHNICAL DATA
ONLY FOR UL MODEL

FEEDING AND POWER (EACH DECK NEEDS TO BE CONNECTED INDEPENDENTLY AND THE LOAD SHOWN BELOW ARE PER DECK)	A.C. V240 3ph 60Hz	Standard feeding	Max power	kW	10,5
			*Medium cons/hour	kWh	5,3
			Ampère Max	A/DECK	25,2
			Connecting cable	AWG/DECK	9
	A.C. V208 3ph 60Hz	Feeding on request	Max power	kW	10,5
			*Medium cons/hour	kWh	5,3
			Ampère Max	A	29,1
			Connecting cable	AWG/DECK	9
	A.C. V240 3ph 60Hz boosted heating elements	Standard feeding	Max power	kW	12,1
			*Medium cons/hour	kWh	6,1
			Ampère Max	A/DECK	29,1
			Connecting cable	AWG/DECK	7
	A.C. V208 3ph 60Hz boosted heating elements	Feeding on request	Max power	kW	12,1
			*Medium cons/hour	kWh	6,1
			Ampère Max	A/DECK	33,6
			Connecting cable	AWG/DECK	7
A.C. V(208/240) 1ph 60Hz	Proofer	Max power	kW	1,8	
		*Medium cons/hour	kWh	0,9	
		Ampère Max	A/DECK	7,5	
		Connecting cable	AWG/DECK	14	

* This value is subject to variation according to the way in which the equipment is used
NOTE: MORETTI FORNI S.P.A. reserves the right to modify the characteristics of the products illustrated in this publication without prior notice



Modular electric deck oven

2 decks composition

Amalfi consists of one or more independent baking chambers and an optional proofer or stand. The baking chamber is entirely made of refractory stone with coiled heating elements inside, allowing the perfect heat distribution over the whole surface. This oven is particularly suitable for direct pizza baking, specific for more delicate toppings and recommended for indirect baking on trays. Temperature management is electronic, power control of ceiling and floor is independent. The oven door is hinged at the bottom, with a tempered glass window to check the product during baking. The stand consists of a painted metal structure, while the proofer is a stainless steel cabinet equipped with a heating thermostat. The proofer can reach the maximum temperature of 65°C(149°F), whereas the maximum temperature of the baking chamber is 450°C (842°F).



OPERATION

- Heated by spiral heating elements
- Electronic temperature management with independent adjustment of ceiling and floor
- Maximum temperature reached 450°C (842°F)
- Continuous temperatures monitoring in baking chamber by thermocouple
- Vapour ducting using manual butterfly valve

CONSTRUCTION

- Structure made in folded stainless steel
- Side panels in painted sheet metal
- Hood in stainless steel
- Steam duct in stainless steel plate
- Stainless steel door, tempered glass
- Refractory top and side structure
- Dual halogen lighting
- Rock wool heat insulation

ACCESSORIES

- Leavening proofer on wheels height 600, 800mm
- Stand with wheels height 600, 800, 950mm
- Spacer element height 300mm
- Additional tray holder guides for compartment and Stand
- Motor for hood vapours extraction 500 m3/h
- Self-condensing hood
- Frontless hood

INTERNAL BAKING DIMENSIONS

Internal height	180mm
Internal depth	1040mm
Internal width	950mm
Baking surface	1,0m ²

- Timer
- Economiser
- Independent maximum temperature safety device

TOP VIEW

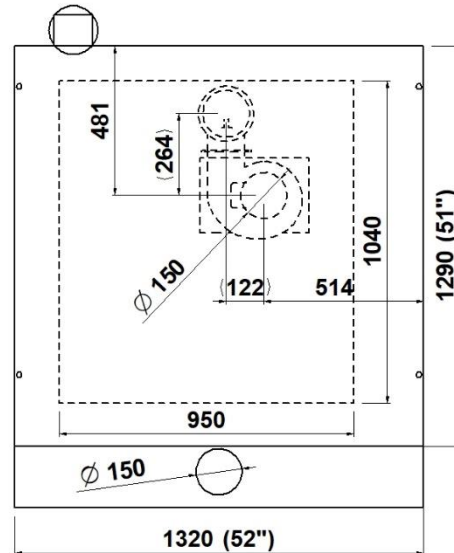

STANDARD EQUIPMENT

- 20 customisable programs

1 baking chamber height 18cm

(assembled with stand height 950mm)

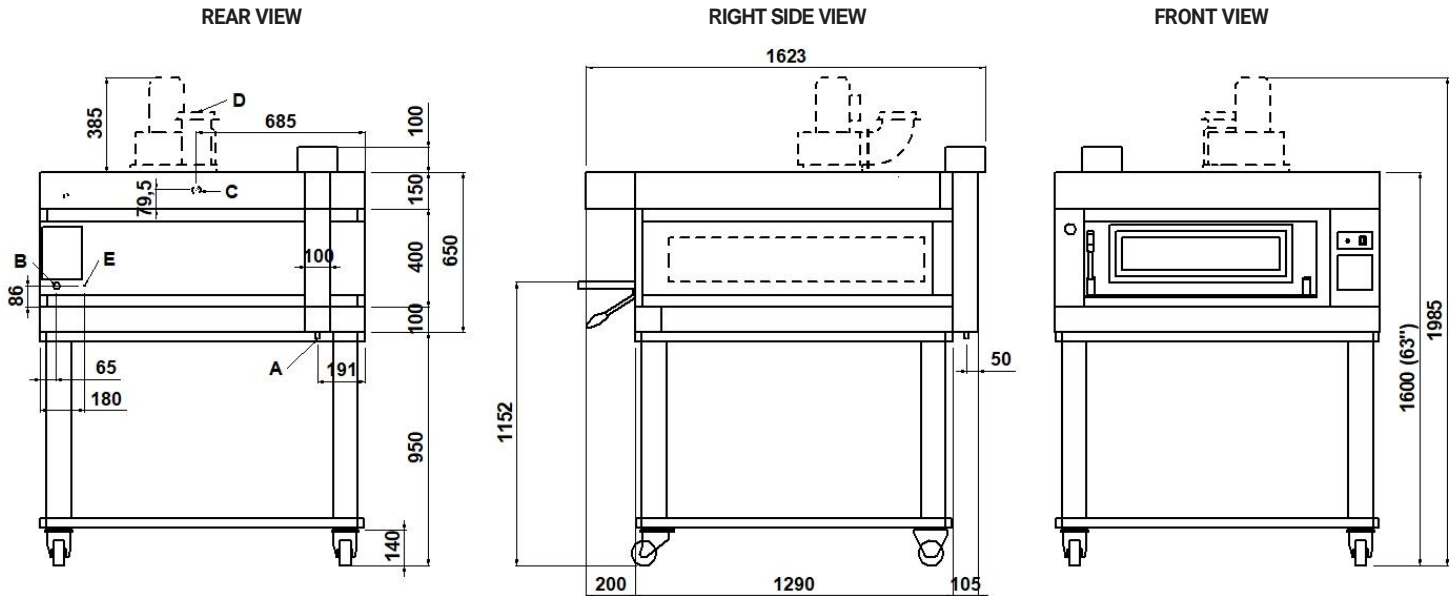

NOTE: The dimensions indicated in the views are in millimeters.

A Ø12 condensate exhaust	B fairleads	C Ø16 hood condensate exhaust	D Ø150 steam exhaust
E M6 equipotential screws			

DIMENSIONS

External height	650mm
External depth	1290mm
External width	1320mm
Weight	273kg

TOTAL BAKING CAPACITY

Tray (600x400)mm	3
Pizza diameter 300mm	9
Pizza diameter 450mm	4

SHIPPING INFORMATION

Packed in wooden crate	
Height	900mm
Depth	1851mm
Width	1520mm
Weight	(273+50)kg
When combined with leavening compartment or Stand:	
Max height	1850mm
Max weight	(381+60)kg

FEEDING AND POWER

<i>Standard feeding</i>	
A.C. V400 3N	
<i>Feeding on request</i>	
A.C. V230 3	
Frequency	50/60Hz
Max power	9,6kW
*Average power cons	4,8kWh
Connecting cable for each chamber	
type H07RN-F	
5x4mm ² (V400 3N)	
4x6mm ² (V230 3)	
Power supply (optional prover)	
A.C. V230 1N 50/60 Hz	
Max power	1,5kW
*Average power cons	0,8kWh
Conn. Cable type H07RN-F 3x1,5mm ²	

* This value is subject to variation according to the way in which the equipment is used

NOTE: MORETTI FORNI S.P.A. reserves the right to modify the characteristics of the products illustrated in this publication without prior notice

2 baking chambers height 18cm

(assembled with prover height 800mm)

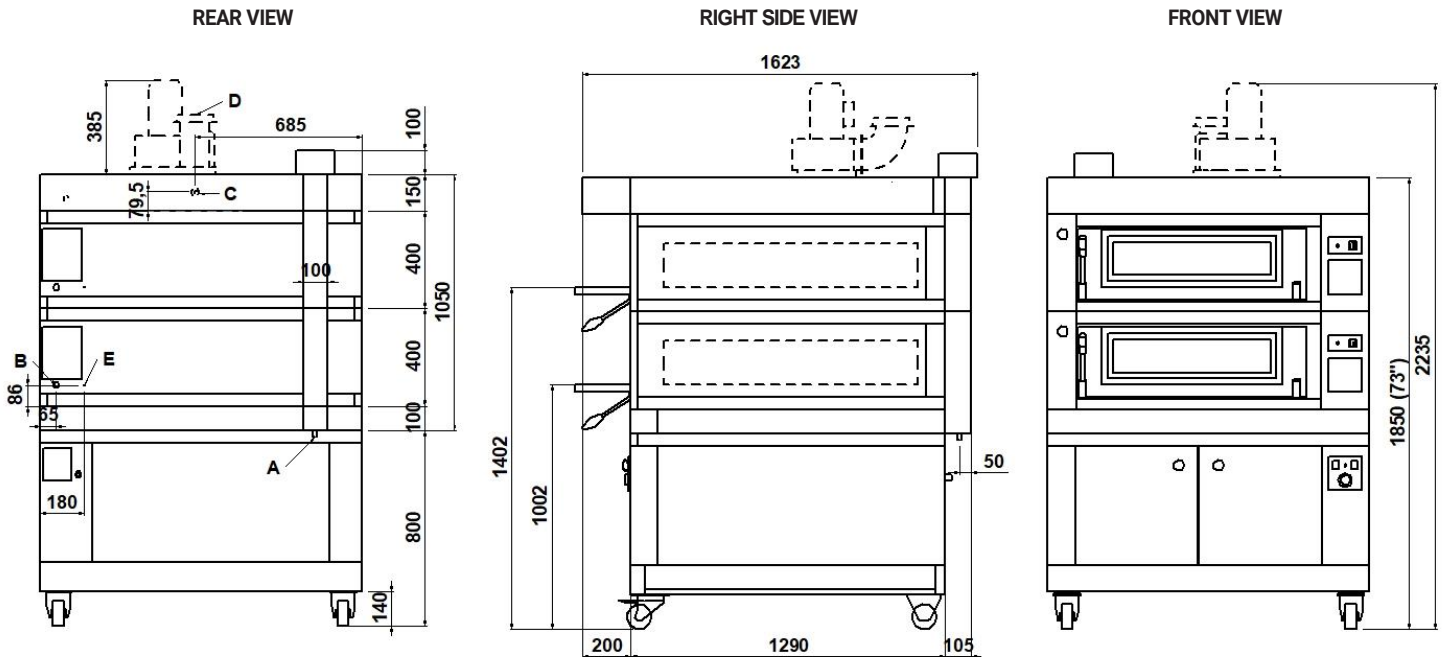

NOTE: The dimensions indicated in the views are in millimeters.

A Ø12 condensate exhaust	B fairleads	C Ø16 Hood condensate exhaust	D Ø150 steam exhaust
E M6 equipotential screws			

DIMENSIONS

External height	1050mm
External depth	1290mm
External width	1320mm
Weight	466kg

SHIPPING INFORMATION

Packed in wooden crate	
Height	1300mm
Depth	1851mm
Width	1520mm
Weight	(466+60)kg

FEEDING AND POWER

<i>Standard feeding</i>	
A.C. V400 3N	
<i>Feeding on request</i>	
A.C. V230 3	
Frequency	50/60Hz
Max power	19,2kW
*Average power cons	9,6kWh
Connecting cable for each chamber	
type H07RN-F	
5x4mm ² (V400 3N)	
4x6mm ² (V230 3)	
Power supply (optional prover)	
A.C. V230 1N 50/60 Hz	
Max power	1,5kW
*Average power cons	0,8kWh
Conn. Cable type H07RN-F	3x1,5mm ²

TOTAL BAKING CAPACITY

Tray (600x400)mm	6	When combined with leavening
Pizza diameter 300mm	18	compartment or Stand:
Pizza diameter 450mm	6	Max height
		2250mm
		Max weight
		(574+70)kg

* This value is subject to variation according to the way in which the equipment is used

NOTE: MORETTI FORNI S.P.A. reserves the right to modify the characteristics of the products illustrated in this publication without prior notice

3 baking chambers height 18cm

(assembled with prover height 600mm)

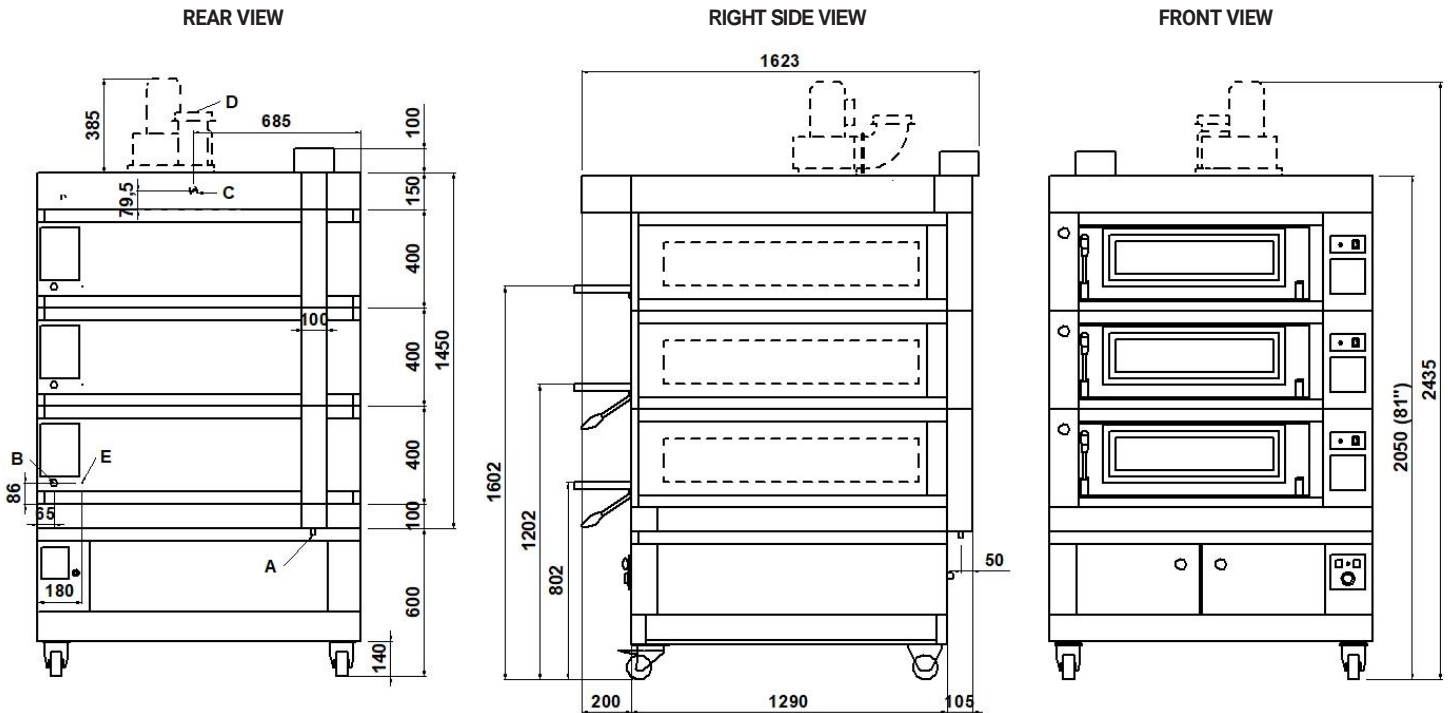

NOTE: The dimensions indicated in the views are in millimeters.

A Ø12 condensate exhaust	B fairleads	C Ø16 Hood condensate exhaust	D Ø150 steam exhaust
E M6 equipotential screws			

DIMENSIONS

External height	1450mm
External depth	1290mm
External width	1320mm
Weight	659kg

SHIPPING INFORMATION

Packed in wooden crate	
Height	1800mm
Depth	1851mm
Width	1520mm
Weight	(659+70)kg

FEEDING AND POWER

<i>Standard feeding</i>	
A.C. V400 3N	
<i>Feeding on request</i>	
A.C. V230 3	
Frequency	50/60Hz
Max power	28,8kW
*Average power cons	14,4kWh
Connecting cable for each chamber	
type H07RN-F	
5x4mm ² (V400 3N)	
4x6mm ² (V230 3)	
Power supply (optional prover)	
A.C. V230 1N 50/60 Hz	
Max power	1,5kW
*Average power cons	0,8kWh
Conn. Cable type H07RN-F 3x1,5mm ²	

TOTAL BAKING CAPACITY

Tray (600x400)mm	9	When combined with leavening compartment or Stand:
Pizza diameter 300mm	27	Max height
Pizza diameter 450mm	12	Max weight

* This value is subject to variation according to the way in which the equipment is used

NOTE: MORETTI FORNI S.P.A. reserves the right to modify the characteristics of the products illustrated in this publication without prior notice

Amalfi C
TECHNICAL DATA

FEEDING AND POWER (REFERRED TO 1 BAKING CHAMBER)	Max power	Standard	kW	9,6
	*Average power consumption		kWh	4,8
	Max power	Boosted heating elements	kW	11,1
	*Average power consumption		kWh	5,6

TECHNICAL DATA
ONLY FOR UL MODEL

FEEDING AND POWER (EACH DECK NEEDS TO BE CONNECTED INDEPENDENTLY AND THE LOAD SHOWN BELOW ARE PER DECK)	A.C. V240 3ph 60Hz	Standard feeding	Max power	kW	10,5
			*Medium cons/hour	kWh	5,3
			Ampère Max	A/DECK	25,2
			Connecting cable	AWG/DECK	9
	A.C. V208 3ph 60Hz	Feeding on request	Max power	kW	10,5
			*Medium cons/hour	kWh	5,3
			Ampère Max	A	29,1
			Connecting cable	AWG/DECK	9
	A.C. V240 3ph 60Hz boosted heating elements	Standard feeding	Max power	kW	12,1
			*Medium cons/hour	kWh	6,1
			Ampère Max	A/DECK	29,1
			Connecting cable	AWG/DECK	7
	A.C. V208 3ph 60Hz boosted heating elements	Feeding on request	Max power	kW	12,1
			*Medium cons/hour	kWh	6,1
			Ampère Max	A/DECK	33,6
			Connecting cable	AWG/DECK	7
A.C. V(208/240) 1ph 60Hz	Proofer	Max power	kW	1,8	
		*Medium cons/hour	kWh	0,9	
		Ampère Max	A/DECK	7,5	
		Connecting cable	AWG/DECK	14	

* This value is subject to variation according to the way in which the equipment is used
NOTE: MORETTI FORNI S.P.A. reserves the right to modify the characteristics of the products illustrated in this publication without prior notice



Modular electric deck oven

2 decks composition

Amalfi consists of one or more independent baking chambers and an optional proofer or stand. The baking chamber is entirely made of refractory stone with coiled heating elements inside, allowing the perfect heat distribution over the whole surface. This oven is particularly suitable for direct pizza baking, specific for more delicate toppings and recommended for indirect baking on trays. Temperature management is electronic, power control of ceiling and floor is independent. The oven door is hinged at the bottom, with a tempered glass window to check the product during baking. The stand consists of a painted metal structure, while the proofer is a stainless steel cabinet equipped with a heating thermostat. The proofer can reach the maximum temperature of 65°C(149°F), whereas the maximum temperature of the baking chamber is 450°C (842°F).



OPERATION

- Heated by spiral heating elements
- Electronic temperature management with independent adjustment of ceiling and floor
- Maximum temperature reached 450°C (842°F)
- Continuous temperatures monitoring in baking chamber by thermocouple
- Vapour ducting using manual butterfly valve

CONSTRUCTION

- Structure made in folded stainless steel
- Side panels in painted sheet metal
- Hood in stainless steel
- Steam duct in stainless steel plate
- Stainless steel door, tempered glass
- Refractory top and side structure
- Dual halogen lighting
- Rock wool heat insulation

ACCESSORIES

- Leavening proofer on wheels height 600, 800mm
- Stand with wheels height 600, 800, 950mm
- Spacer element height 300mm
- Additional tray holder guides for compartment and Stand
- Motor for hood vapours extraction 500 m3/h
- Self-condensing hood
- Frontless hood

INTERNAL BAKING DIMENSIONS

Internal height	180mm
Internal depth	1040mm
Internal width	950mm
Baking surface	1,0m ²

- Timer
- Economiser
- Independent maximum temperature safety device

TOP VIEW

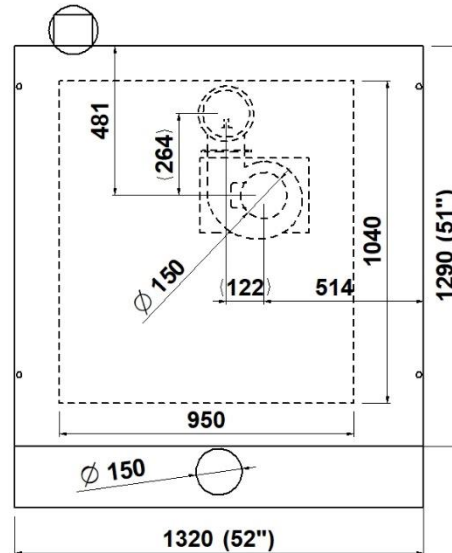

STANDARD EQUIPMENT

- 20 customisable programs

1 baking chamber height 18cm

(assembled with stand height 950mm)

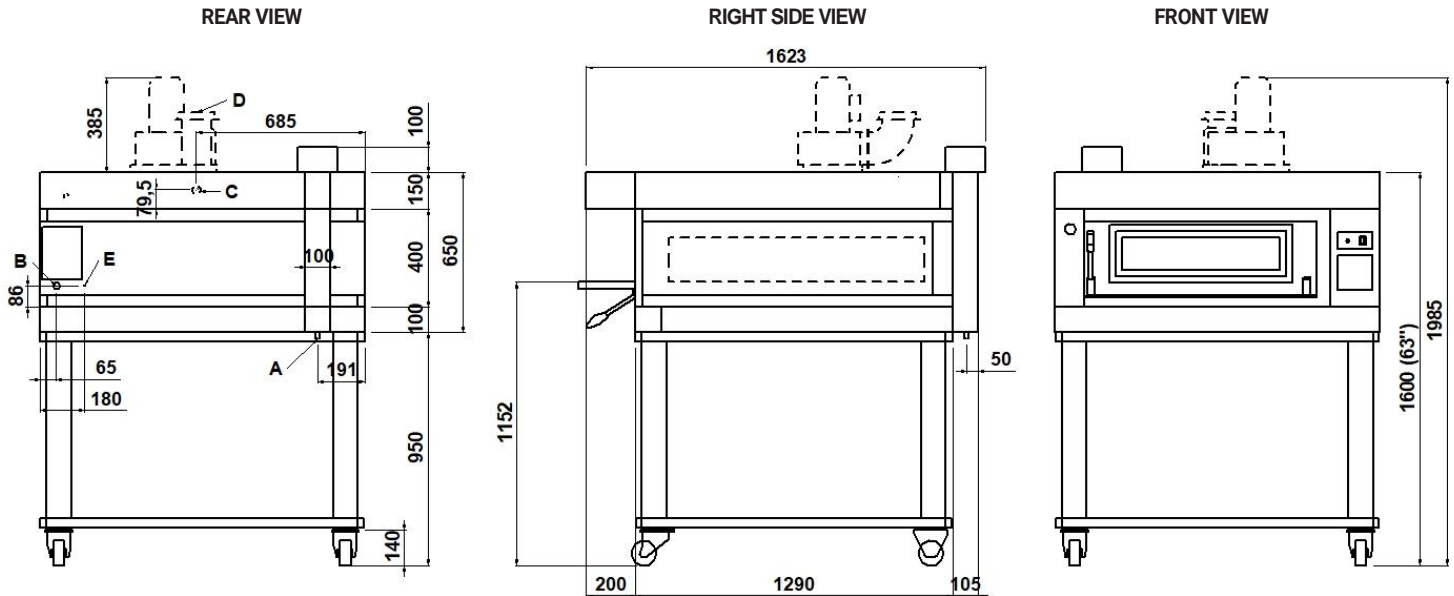

NOTE: The dimensions indicated in the views are in millimeters.

A Ø12 condensate exhaust	B fairleads	C Ø16 hood condensate exhaust	D Ø150 steam exhaust
E M6 equipotential screws			

DIMENSIONS

External height	650mm
External depth	1290mm
External width	1320mm
Weight	273kg

TOTAL BAKING CAPACITY

Tray (600x400)mm	3
Pizza diameter 300mm	9
Pizza diameter 450mm	4

SHIPPING INFORMATION

Packed in wooden crate	
Height	900mm
Depth	1851mm
Width	1520mm
Weight	(273+50)kg
When combined with leavening compartment or Stand:	
Max height	1850mm
Max weight	(381+60)kg

FEEDING AND POWER

<i>Standard feeding</i>	
A.C. V400 3N	
<i>Feeding on request</i>	
A.C. V230 3	
Frequency	50/60Hz
Max power	9,6kW
*Average power cons	4,8kWh
Connecting cable for each chamber	
type H07RN-F	
5x4mm ² (V400 3N)	
4x6mm ² (V230 3)	
Power supply (optional prover)	
A.C. V230 1N 50/60 Hz	
Max power	1,5kW
*Average power cons	0,8kWh
Conn. Cable type H07RN-F 3x1,5mm ²	

* This value is subject to variation according to the way in which the equipment is used

NOTE: MORETTI FORNI S.P.A. reserves the right to modify the characteristics of the products illustrated in this publication without prior notice

2 baking chambers height 18cm

(assembled with prover height 800mm)

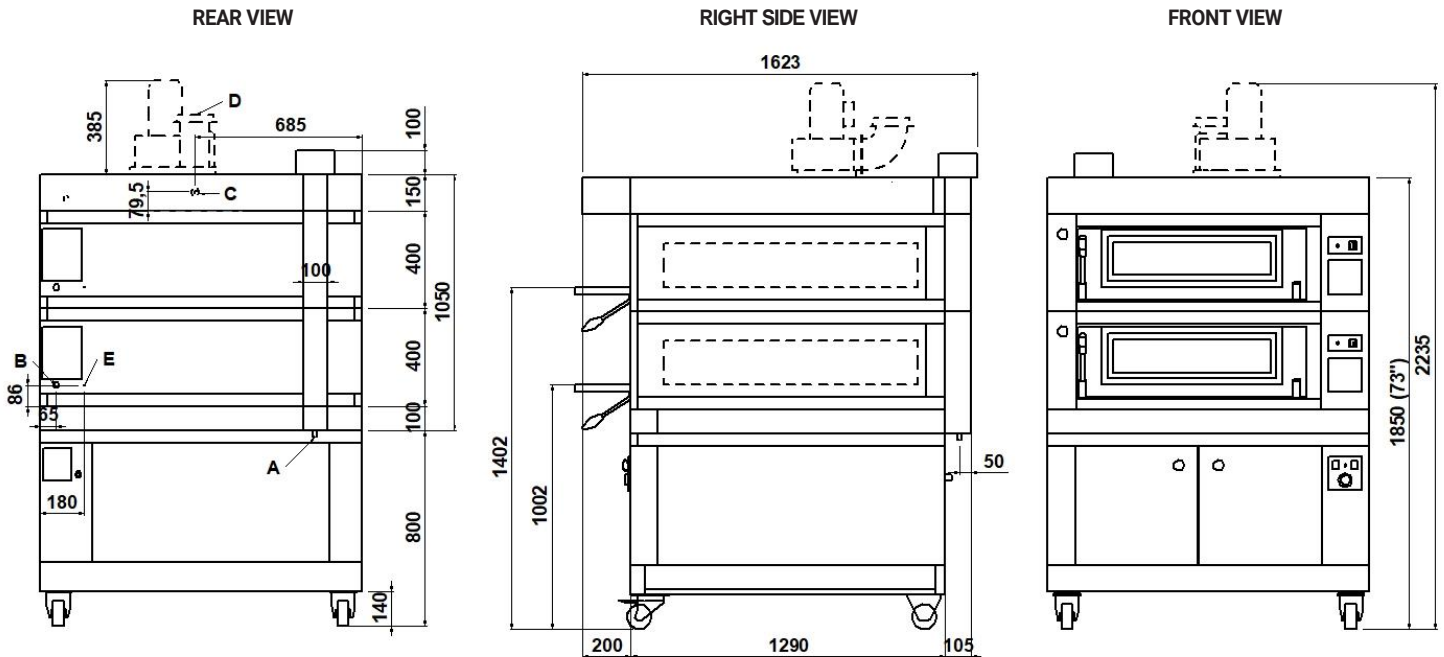

NOTE: The dimensions indicated in the views are in millimeters.

A Ø12 condensate exhaust	B fairleads	C Ø16 Hood condensate exhaust	D Ø150 steam exhaust
E M6 equipotential screws			

DIMENSIONS

External height	1050mm
External depth	1290mm
External width	1320mm
Weight	466kg

SHIPPING INFORMATION

Packed in wooden crate	
Height	1300mm
Depth	1851mm
Width	1520mm
Weight	(466+60)kg

FEEDING AND POWER

<i>Standard feeding</i>	
A.C. V400 3N	
<i>Feeding on request</i>	
A.C. V230 3	
Frequency	50/60Hz
Max power	19,2kW
*Average power cons	9,6kWh
Connecting cable for each chamber	
type H07RN-F	
5x4mm ² (V400 3N)	
4x6mm ² (V230 3)	
Power supply (optional prover)	
A.C. V230 1N 50/60 Hz	
Max power	1,5kW
*Average power cons	0,8kWh
Conn. Cable type H07RN-F	3x1,5mm ²

TOTAL BAKING CAPACITY

Tray (600x400)mm	6	When combined with leavening
Pizza diameter 300mm	18	compartment or Stand:
Pizza diameter 450mm	6	Max height
		2250mm
		Max weight
		(574+70)kg

* This value is subject to variation according to the way in which the equipment is used

NOTE: MORETTI FORNI S.P.A. reserves the right to modify the characteristics of the products illustrated in this publication without prior notice

3 baking chambers height 18cm

(assembled with prover height 600mm)

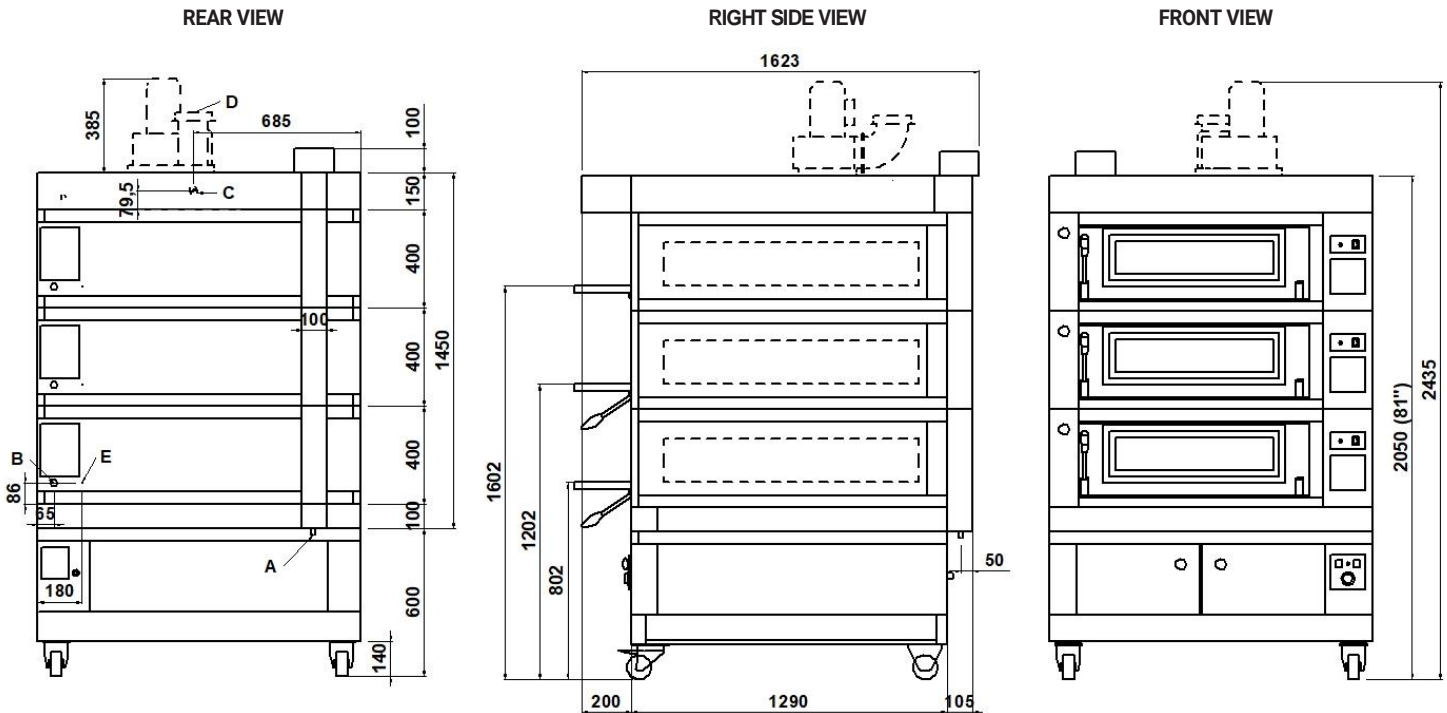

NOTE: The dimensions indicated in the views are in millimeters.

A Ø12 condensate exhaust	B fairleads	C Ø16 Hood condensate exhaust	D Ø150 steam exhaust
E M6 equipotential screws			

DIMENSIONS

External height	1450mm
External depth	1290mm
External width	1320mm
Weight	659kg

SHIPPING INFORMATION

Packed in wooden crate	
Height	1800mm
Depth	1851mm
Width	1520mm
Weight	(659+70)kg

FEEDING AND POWER

<i>Standard feeding</i>	
A.C. V400 3N	
<i>Feeding on request</i>	
A.C. V230 3	
Frequency	50/60Hz
Max power	28,8kW
*Average power cons	14,4kWh
Connecting cable for each chamber	
type H07RN-F	
5x4mm ² (V400 3N)	
4x6mm ² (V230 3)	
Power supply (optional prover)	
A.C. V230 1N 50/60 Hz	
Max power	1,5kW
*Average power cons	0,8kWh
Conn. Cable type H07RN-F 3x1,5mm ²	

TOTAL BAKING CAPACITY

Tray (600x400)mm	9	When combined with leavening compartment or Stand:
Pizza diameter 300mm	27	Max height
Pizza diameter 450mm	12	Max weight

* This value is subject to variation according to the way in which the equipment is used

NOTE: MORETTI FORNI S.P.A. reserves the right to modify the characteristics of the products illustrated in this publication without prior notice

Amalfi C
TECHNICAL DATA

FEEDING AND POWER (REFERRED TO 1 BAKING CHAMBER)	Max power	Standard	kW	9,6
	*Average power consumption		kWh	4,8
	Max power	Boosted heating elements	kW	11,1
	*Average power consumption		kWh	5,6

TECHNICAL DATA
ONLY FOR UL MODEL

FEEDING AND POWER (EACH DECK NEEDS TO BE CONNECTED INDEPENDENTLY AND THE LOAD SHOWN BELOW ARE PER DECK)	A.C. V240 3ph 60Hz	Standard feeding	Max power	kW	10,5
			*Medium cons/hour	kWh	5,3
			Ampère Max	A/DECK	25,2
			Connecting cable	AWG/DECK	9
	A.C. V208 3ph 60Hz	Feeding on request	Max power	kW	10,5
			*Medium cons/hour	kWh	5,3
			Ampère Max	A	29,1
			Connecting cable	AWG/DECK	9
	A.C. V240 3ph 60Hz boosted heating elements	Standard feeding	Max power	kW	12,1
			*Medium cons/hour	kWh	6,1
			Ampère Max	A/DECK	29,1
			Connecting cable	AWG/DECK	7
	A.C. V208 3ph 60Hz boosted heating elements	Feeding on request	Max power	kW	12,1
			*Medium cons/hour	kWh	6,1
			Ampère Max	A/DECK	33,6
			Connecting cable	AWG/DECK	7
A.C. V(208/240) 1ph 60Hz	Proofer	Max power	kW	1,8	
		*Medium cons/hour	kWh	0,9	
		Ampère Max	A/DECK	7,5	
		Connecting cable	AWG/DECK	14	

* This value is subject to variation according to the way in which the equipment is used
NOTE: MORETTI FORNI S.P.A. reserves the right to modify the characteristics of the products illustrated in this publication without prior notice



Modular electric deck oven

2 decks composition

Amalfi consists of one or more independent baking chambers and an optional proofer or stand. The baking chamber is entirely made of refractory stone with coiled heating elements inside, allowing the perfect heat distribution over the whole surface. This oven is particularly suitable for direct pizza baking, specific for more delicate toppings and recommended for indirect baking on trays. Temperature management is electronic, power control of ceiling and floor is independent. The oven door is hinged at the bottom, with a tempered glass window to check the product during baking. The stand consists of a painted metal structure, while the proofer is a stainless steel cabinet equipped with a heating thermostat. The proofer can reach the maximum temperature of 65°C(149°F), whereas the maximum temperature of the baking chamber is 450°C (842°F).



OPERATION

- Heated by spiral heating elements
- Electronic temperature management with independent adjustment of ceiling and floor
- Maximum temperature reached 450°C (842°F)
- Continuous temperatures monitoring in baking chamber by thermocouple
- Vapour ducting using manual butterfly valve

CONSTRUCTION

- Structure made in folded stainless steel
- Side panels in painted sheet metal
- Hood in stainless steel
- Steam duct in stainless steel plate
- Stainless steel door, tempered glass
- Refractory top and side structure
- Dual halogen lighting
- Rock wool heat insulation

ACCESSORIES

- Leavening proofer on wheels height 600, 800mm
- Stand with wheels height 600, 800, 950mm
- Spacer element height 300mm
- Additional tray holder guides for compartment and stand
- Motor for hood vapours extraction 500 m3/h
- Self-condensing hood
- Frontless hood

INTERNAL BAKING DIMENSIONS

Internal height	180mm
Internal depth	1040mm
Internal width	650mm
Baking surface	0,7m ²

- Timer
- Economiser
- Independent maximum temperature safety device

TOP VIEW

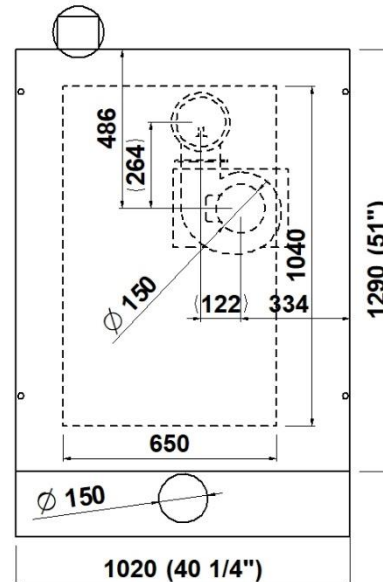

STANDARD EQUIPMENT

- 20 customisable programs

1 baking chamber height 18cm

(assembled with stand height 950mm)

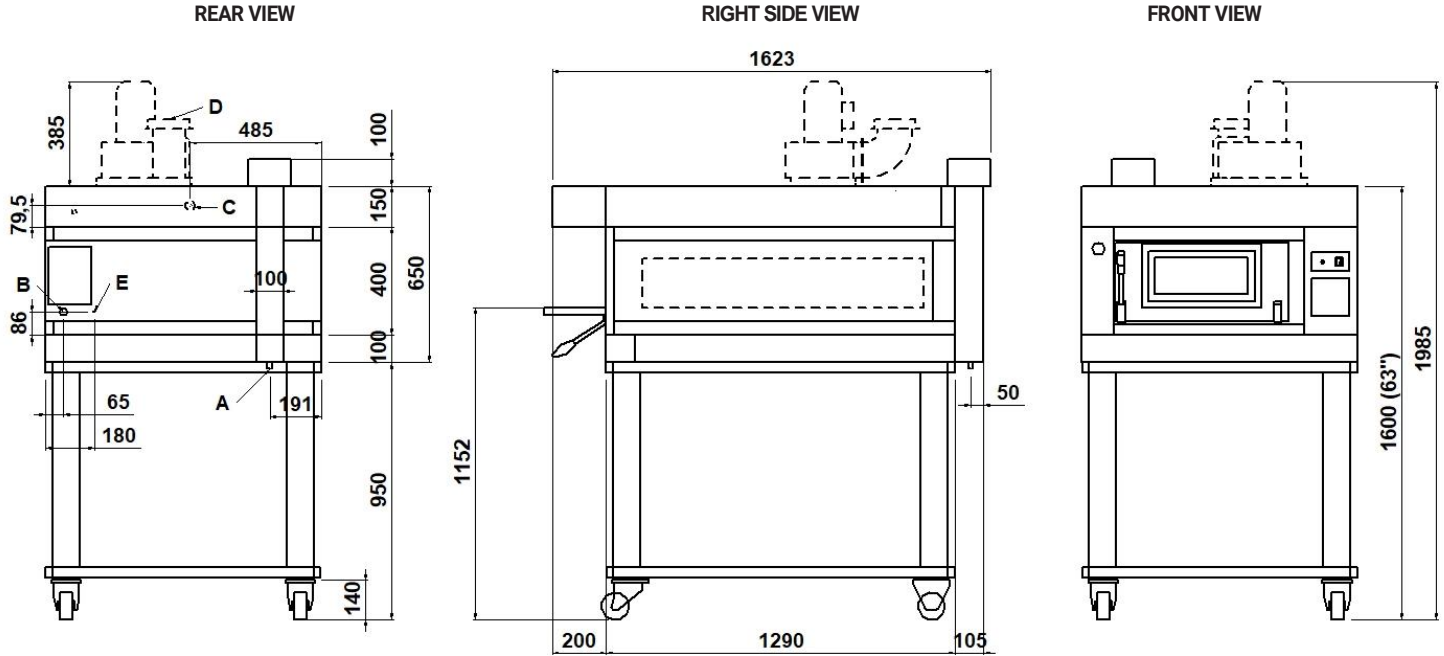

NOTE: The dimensions indicated in the views are in millimeters.

A Ø12 condensate exhaust	B fairleads	C Ø16 hood condensate exhaust	D Ø150 steam exhaust
E M6 equipotential screws			

DIMENSIONS

External height	650mm
External depth	1290mm
External width	1020mm
Weight	222kg

TOTAL BAKING CAPACITY

Tray (600x400)mm	2
Pizza diameter 300mm	6
Pizza diameter 450mm	2

SHIPPING INFORMATION

Packed in wooden crate	
Height	900mm
Depth	1851mm
Width	1220mm
Weight	(222+50)kg
When combined with leavening compartment or stand:	
Max height	1850mm
Max weight	(305+60)kg

FEEDING AND POWER

<i>Standard feeding</i>	
A.C. V400 3N	
<i>Feeding on request</i>	
A.C. V230 3	
Frequency	50/60Hz
Max power	7,1kW
*Average power cons	3,6kWh
Connecting cable for each chamber	
type H07RN-F	
5x4mm ² (V400 3N)	
4x6mm ² (V230 3)	
Power supply (optional prover)	
A.C. V230 1N 50/60 Hz	
Max power	1,5kW
*Average power cons	0,8kWh
Conn. Cable type H07RN-F 3x1,5mm ²	

* This value is subject to variation according to the way in which the equipment is used

NOTE: MORETTI FORNI S.P.A. reserves the right to modify the characteristics of the products illustrated in this publication without prior notice

2 baking chambers height 18cm
(assembled with prover height 800mm)

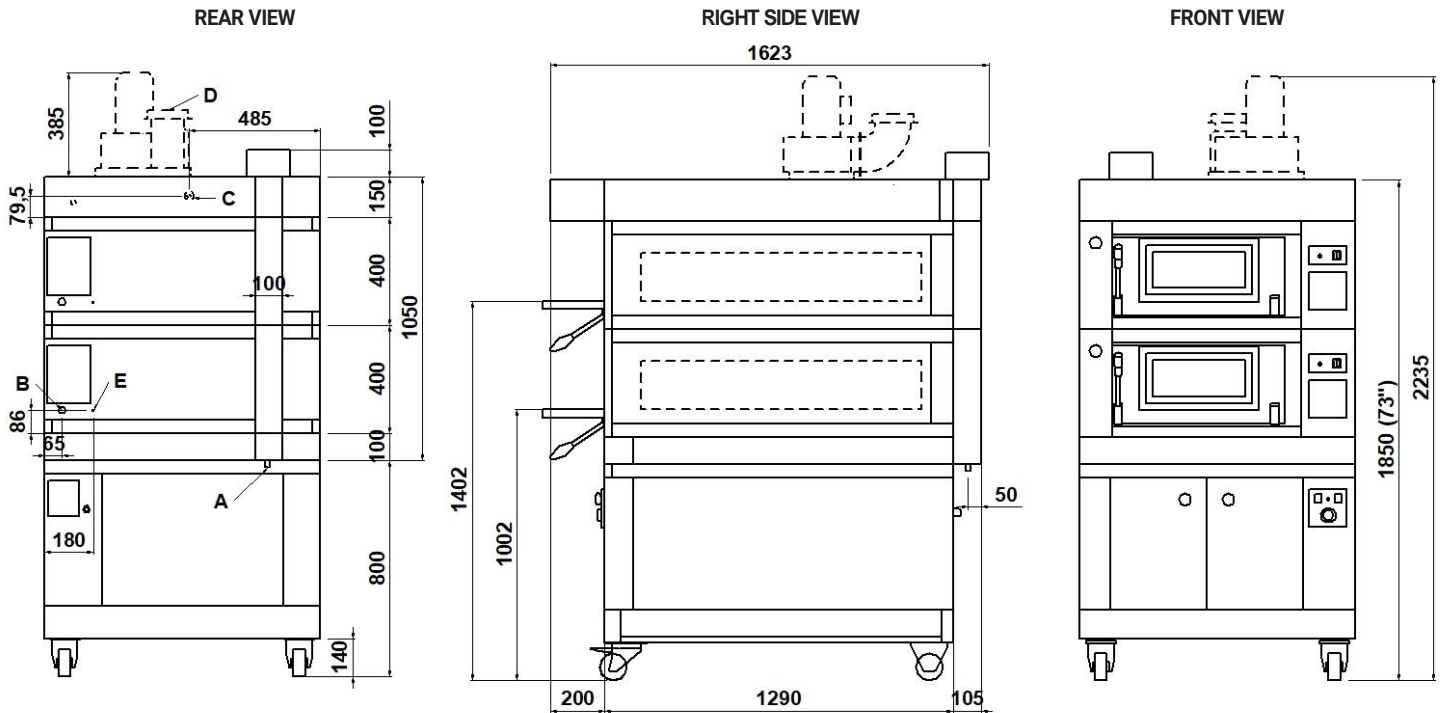

NOTE: The dimensions indicated in the views are in millimeters.

A Ø12 condensate exhaust	B fairleads	C Ø16 Hood condensate exhaust	D Ø150 steam exhaust
E M6 equipotential screws			

DIMENSIONS

External height	1050mm
External depth	1290mm
External width	1020mm
Weight	378kg

TOTAL BAKING CAPACITY

Tray (600x400)mm	4
Pizza diameter 300mm	12
Pizza diameter 450mm	4

SHIPPING INFORMATION

Packed in wooden crate	
Height	1300mm
Depth	1851mm
Width	1220mm
Weight	(378+60)kg

When combined with leavening compartment or stand:	
Max height	2250mm
Max weight	(461+70)kg

FEEDING AND POWER

<i>Standard feeding</i>	
A.C. V400 3N	
<i>Feeding on request</i>	
A.C. V230 3	
Frequency	50/60Hz
Max power	14,2kW
*Average power cons	7,1kWh
Connecting cable for each chamber	
type H07RN-F	
5x4mm ² (V400 3N)	
4x6mm ² (V230 3)	
Power supply (optional prover)	
A.C. V230 1N 50/60 Hz	
Max power	1,5kW
*Average power cons	0,8kWh
Conn. Cable type H07RN-F 3x1,5mm ²	

* This value is subject to variation according to the way in which the equipment is used

NOTE: MORETTI FORNI S.P.A. reserves the right to modify the characteristics of the products illustrated in this publication without prior notice

3 baking chambers height 18cm
(assembled with prover height 600mm)

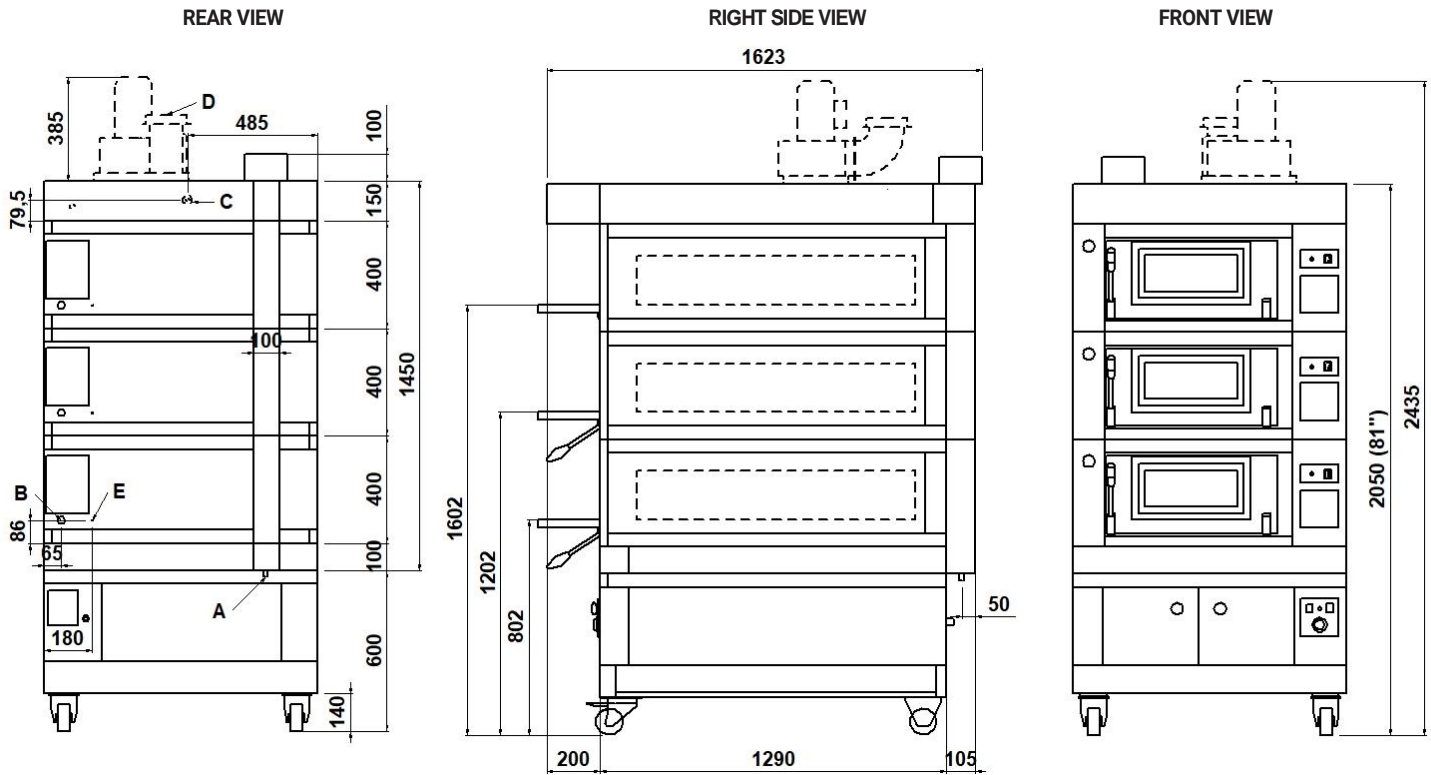

NOTE: The dimensions indicated in the views are in millimeters.

A Ø12 condensate exhaust	B fairleads	C Ø16 Hood condensate exhaust	D Ø150 steam exhaust
E M6 equipotential screws			

DIMENSIONS

External height	1450mm
External depth	1290mm
External width	1020mm
Weight	534kg

SHIPPING INFORMATION

Packed in wooden crate	
Height	1800mm
Depth	1851mm
Width	1220mm
Weight	(534+70)kg

FEEDING AND POWER

<i>Standard feeding</i>	
A.C. V400 3N	
<i>Feeding on request</i>	
A.C. V230 3	
Frequency	50/60Hz
Max power	21,3kW
*Average power cons	10,6kWh
Connecting cable for each chamber	
type H07RN-F	
5x4mm ² (V400 3N)	
4x6mm ² (V230 3)	
Power supply (optional prover)	
A.C. V230 1N 50/60 Hz	
Max power	1,5kW
*Average power cons	0,8kWh
Conn. Cable type H07RN-F 3x1,5mm ²	

TOTAL BAKING CAPACITY

Tray (600x400)mm	6	When combined with leavening compartment or stand:	
Pizza diameter 300mm	18		
Pizza diameter 450mm	6		
		Max height	2750mm
		Max weight	(617+80)kg

* This value is subject to variation according to the way in which the equipment is used

NOTE: MORETTI FORNI S.P.A. reserves the right to modify the characteristics of the products illustrated in this publication without prior notice

Amalfi A
TECHNICAL DATA

FEEDING AND POWER (REFERRED TO 1 BAKING CHAMBER)	Max power	Standard	kW	7,1
	*Average power consumption		kWh	3,6
	Max power	Boosted heating elements	kW	9,6
	*Average power consumption		kWh	4,8

TECHNICAL DATA
ONLY FOR UL MODEL

FEEDING AND POWER (EACH DECK NEEDS TO BE CONNECTED INDEPENDENTLY AND THE LOAD SHOWN BELOW ARE PER DECK)	A.C. V240 3ph 60Hz	Standard feeding	Max power	kW	7,7
			*Medium cons/hour	kWh	3,8
			Ampère Max	A/DECK	18,5
			Connecting cable	AWG/DECK	9
	A.C. V208 3ph 60Hz	Feeding on request	Max power	kW	7,7
			*Medium cons/hour	kWh	3,8
			Ampère Max	A	21,7
			Connecting cable	AWG/DECK	9
	A.C. V240 3ph 60Hz boosted heating elements	Standard feeding	Max power	kW	10,5
			*Medium cons/hour	kWh	5,3
			Ampère Max	A/DECK	25,2
			Connecting cable	AWG/DECK	9
	A.C. V208 3ph 60Hz boosted heating elements	Feeding on request	Max power	kW	10,5
			*Medium cons/hour	kWh	5,3
			Ampère Max	A/DECK	29,1
			Connecting cable	AWG/DECK	9
A.C. V(208/240) 1ph 60Hz	Proofer	Max power	kW	1,8	
		*Medium cons/hour	kWh	0,9	
		Ampère Max	A/DECK	7,5	
		Connecting cable	AWG/DECK	14	

* This value is subject to variation according to the way in which the equipment is used
NOTE: MORETTI FORNI S.P.A. reserves the right to modify the characteristics of the products illustrated in this publication without prior notice



Modular electric deck oven

2 decks composition

Amalfi consists of one or more independent baking chambers and an optional proofer or stand. The baking chamber is entirely made of refractory stone with coiled heating elements inside, allowing the perfect heat distribution over the whole surface. This oven is particularly suitable for direct pizza baking, specific for more delicate toppings and recommended for indirect baking on trays. Temperature management is electronic, power control of ceiling and floor is independent. The oven door is hinged at the bottom, with a tempered glass window to check the product during baking. The stand consists of a painted metal structure, while the proofer is a stainless steel cabinet equipped with a heating thermostat. The proofer can reach the maximum temperature of 65°C(149°F), whereas the maximum temperature of the baking chamber is 450°C (842°F).



OPERATION

- Heated by spiral heating elements
- Electronic temperature management with independent adjustment of ceiling and floor
- Maximum temperature reached 450°C (842°F)
- Continuous temperatures monitoring in baking chamber by thermocouple
- Vapour ducting using manual butterfly valve

CONSTRUCTION

- Structure made in folded stainless steel
- Side panels in painted sheet metal
- Hood in stainless steel
- Steam duct in stainless steel plate
- Stainless steel door, tempered glass
- Refractory top and side structure
- Dual halogen lighting
- Rock wool heat insulation

ACCESSORIES

- Leavening proofer on wheels height 600, 800mm
- Stand with wheels height 600, 800, 950mm
- Spacer element height 300mm
- Additional tray holder guides for compartment and stand
- Motor for hood vapours extraction 500 m3/h
- Self-condensing hood
- Frontless hood

INTERNAL BAKING DIMENSIONS

Internal height	180mm
Internal depth	1040mm
Internal width	650mm
Baking surface	0,7m ²

- Timer
- Economiser
- Independent maximum temperature safety device

TOP VIEW

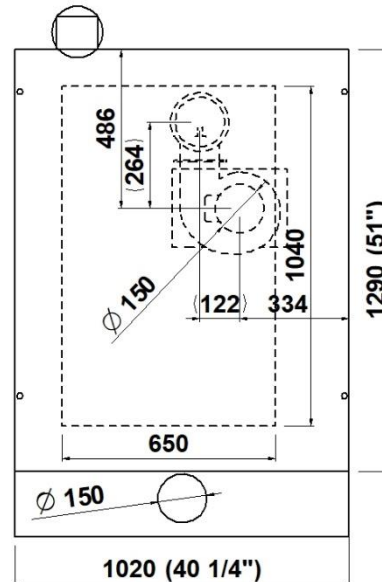

STANDARD EQUIPMENT

- 20 customisable programs

1 baking chamber height 18cm

(assembled with stand height 950mm)

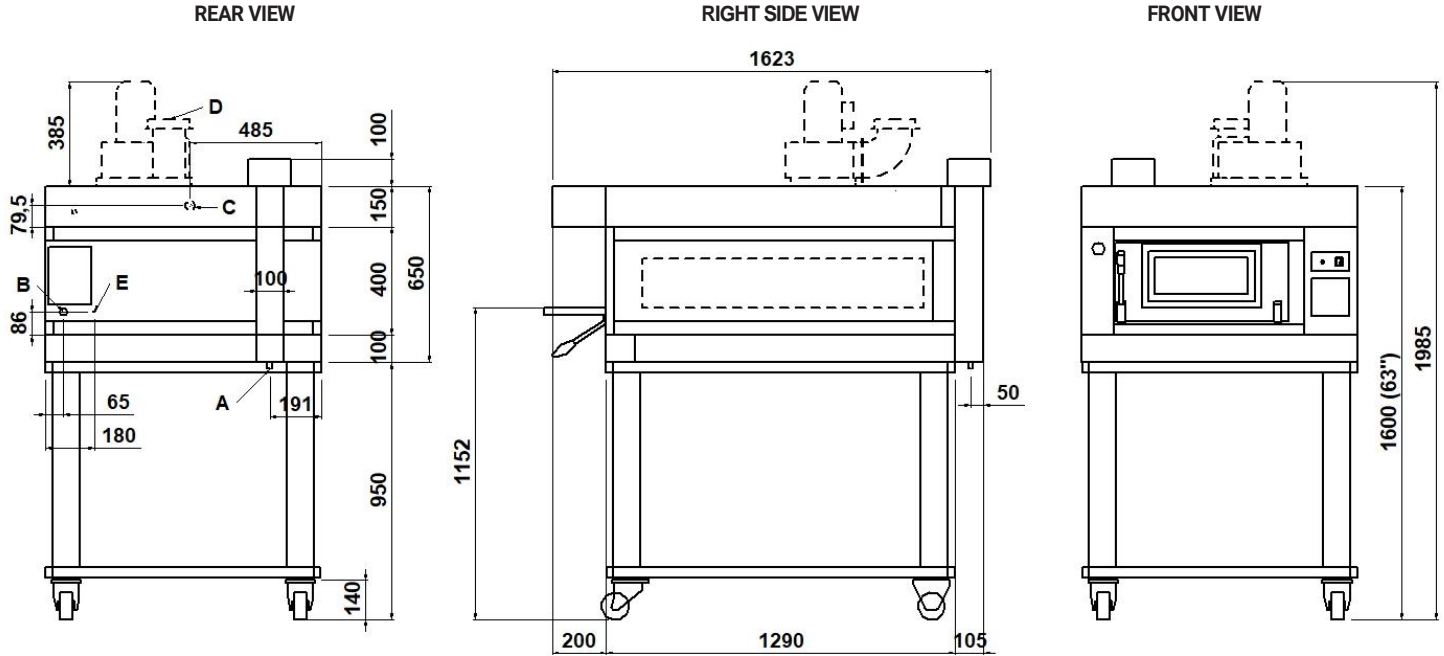

NOTE: The dimensions indicated in the views are in millimeters.

A Ø12 condensate exhaust	B fairleads	C Ø16 hood condensate exhaust	D Ø150 steam exhaust
E M6 equipotential screws			

DIMENSIONS

External height	650mm
External depth	1290mm
External width	1020mm
Weight	222kg

TOTAL BAKING CAPACITY

Tray (600x400)mm	2
Pizza diameter 300mm	6
Pizza diameter 450mm	2

SHIPPING INFORMATION

Packed in wooden crate	
Height	900mm
Depth	1851mm
Width	1220mm
Weight	(222+50)kg
When combined with leavening compartment or stand:	
Max height	1850mm
Max weight	(305+60)kg

FEEDING AND POWER

<i>Standard feeding</i>	
A.C. V400 3N	
<i>Feeding on request</i>	
A.C. V230 3	
Frequency	50/60Hz
Max power	7,1kW
*Average power cons	3,6kWh
Connecting cable for each chamber	
type H07RN-F	
5x4mm ² (V400 3N)	
4x6mm ² (V230 3)	
Power supply (optional prover)	
A.C. V230 1N 50/60 Hz	
Max power	1,5kW
*Average power cons	0,8kWh
Conn. Cable type H07RN-F 3x1,5mm ²	

* This value is subject to variation according to the way in which the equipment is used

NOTE: MORETTI FORNI S.P.A. reserves the right to modify the characteristics of the products illustrated in this publication without prior notice

2 baking chambers height 18cm
(assembled with prover height 800mm)

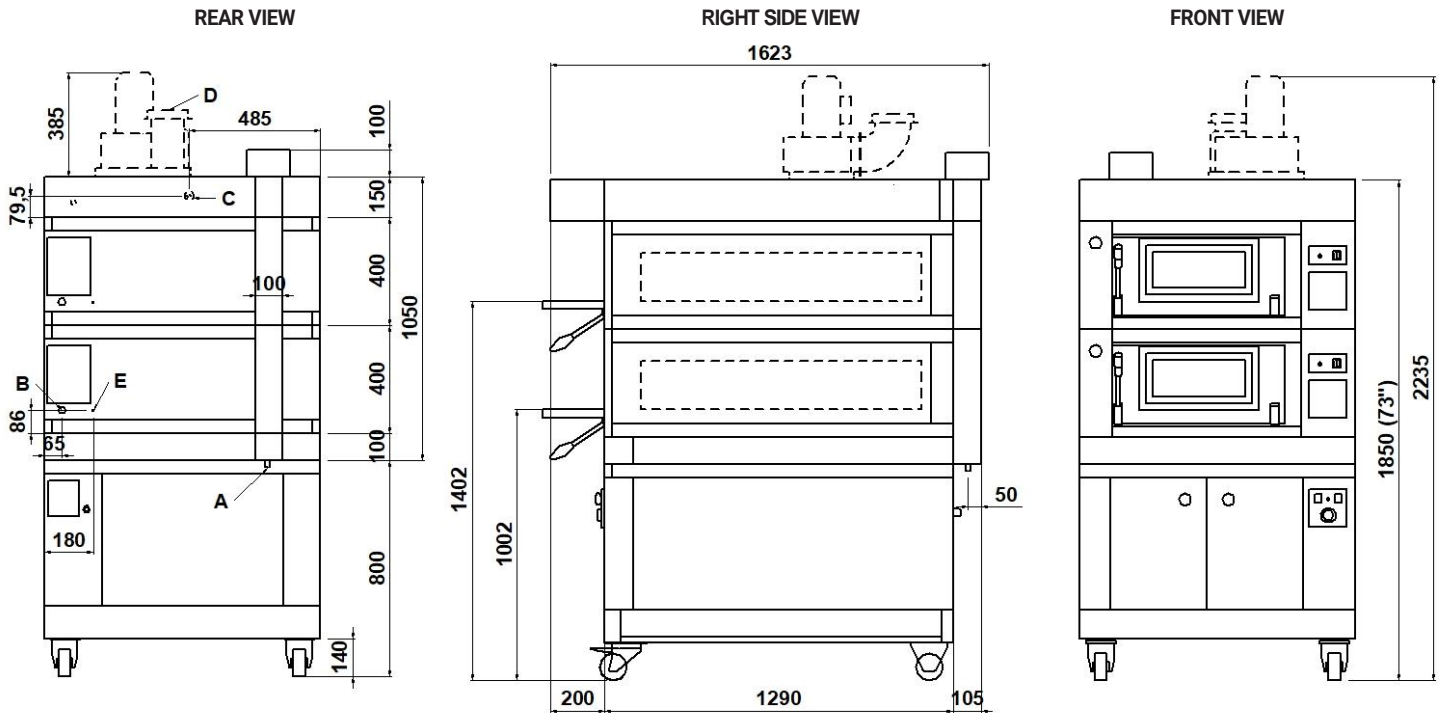

NOTE: The dimensions indicated in the views are in millimeters.

A Ø12 condensate exhaust	B fairleads	C Ø16 Hood condensate exhaust	D Ø150 steam exhaust
E M6 equipotential screws			

DIMENSIONS

External height	1050mm
External depth	1290mm
External width	1020mm
Weight	378kg

TOTAL BAKING CAPACITY

Tray (600x400)mm	4
Pizza diameter 300mm	12
Pizza diameter 450mm	4

SHIPPING INFORMATION

Packed in wooden crate	
Height	1300mm
Depth	1851mm
Width	1220mm
Weight	(378+60)kg

When combined with leavening compartment or stand:	
Max height	2250mm
Max weight	(461+70)kg

FEEDING AND POWER

<i>Standard feeding</i>	
A.C. V400 3N	
<i>Feeding on request</i>	
A.C. V230 3	
Frequency	50/60Hz
Max power	14,2kW
*Average power cons	7,1kWh
Connecting cable for each chamber	
type H07RN-F	
5x4mm ² (V400 3N)	
4x6mm ² (V230 3)	
Power supply (optional prover)	
A.C. V230 1N 50/60 Hz	
Max power	1,5kW
*Average power cons	0,8kWh
Conn. Cable type H07RN-F 3x1,5mm ²	

* This value is subject to variation according to the way in which the equipment is used

NOTE: MORETTI FORNI S.P.A. reserves the right to modify the characteristics of the products illustrated in this publication without prior notice

3 baking chambers height 18cm

(assembled with prover height 600mm)

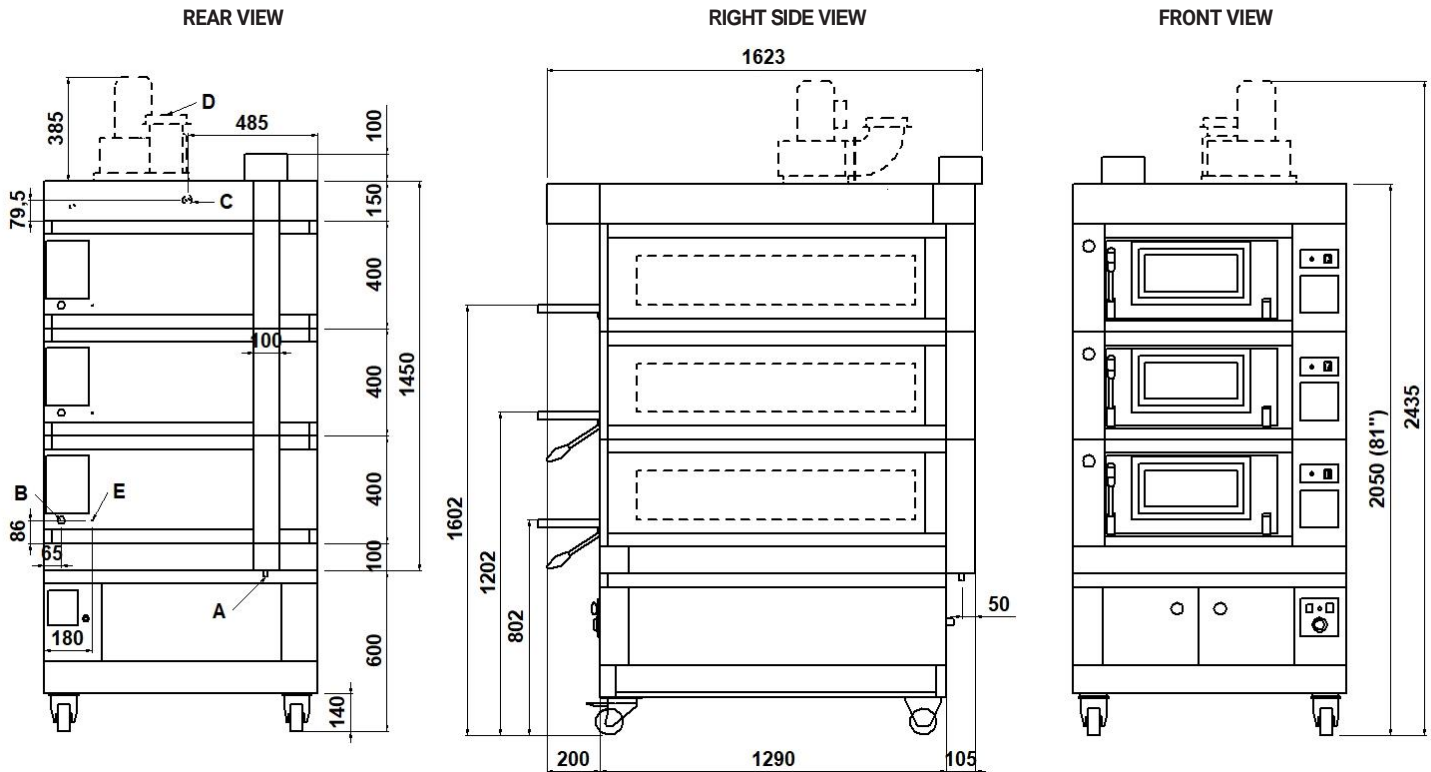

NOTE: The dimensions indicated in the views are in millimeters.

A Ø12 condensate exhaust	B fairleads	C Ø16 Hood condensate exhaust	D Ø150 steam exhaust
E M6 equipotential screws			

DIMENSIONS

External height	1450mm
External depth	1290mm
External width	1020mm
Weight	534kg

SHIPPING INFORMATION

Packed in wooden crate	
Height	1800mm
Depth	1851mm
Width	1220mm
Weight	(534+70)kg

FEEDING AND POWER

<i>Standard feeding</i>	
A.C. V400 3N	
<i>Feeding on request</i>	
A.C. V230 3	
Frequency	50/60Hz
Max power	21,3kW
*Average power cons	10,6kWh
Connecting cable for each chamber	
type H07RN-F	
5x4mm ² (V400 3N)	
4x6mm ² (V230 3)	
Power supply (optional prover)	
A.C. V230 1N 50/60 Hz	
Max power	1,5kW
*Average power cons	0,8kWh
Conn. Cable type H07RN-F 3x1,5mm ²	

TOTAL BAKING CAPACITY

Tray (600x400)mm	6	When combined with leavening compartment or stand:
Pizza diameter 300mm	18	
Pizza diameter 450mm	6	
Max height		2750mm
Max weight		(617+80)kg

* This value is subject to variation according to the way in which the equipment is used

NOTE: MORETTI FORNI S.P.A. reserves the right to modify the characteristics of the products illustrated in this publication without prior notice

Amalfi A
TECHNICAL DATA

FEEDING AND POWER (REFERRED TO 1 BAKING CHAMBER)	Max power	Standard	kW	7,1
	*Average power consumption		kWh	3,6
	Max power	Boosted heating elements	kW	9,6
	*Average power consumption		kWh	4,8

TECHNICAL DATA
ONLY FOR UL MODEL

FEEDING AND POWER (EACH DECK NEEDS TO BE CONNECTED INDEPENDENTLY AND THE LOAD SHOWN BELOW ARE PER DECK)	A.C. V240 3ph 60Hz	Standard feeding	Max power	kW	7,7
			*Medium cons/hour	kWh	3,8
			Ampère Max	A/DECK	18,5
			Connecting cable	AWG/DECK	9
	A.C. V208 3ph 60Hz	Feeding on request	Max power	kW	7,7
			*Medium cons/hour	kWh	3,8
			Ampère Max	A	21,7
			Connecting cable	AWG/DECK	9
	A.C. V240 3ph 60Hz boosted heating elements	Standard feeding	Max power	kW	10,5
			*Medium cons/hour	kWh	5,3
			Ampère Max	A/DECK	25,2
			Connecting cable	AWG/DECK	9
	A.C. V208 3ph 60Hz boosted heating elements	Feeding on request	Max power	kW	10,5
			*Medium cons/hour	kWh	5,3
			Ampère Max	A/DECK	29,1
			Connecting cable	AWG/DECK	9
A.C. V(208/240) 1ph 60Hz	Proofer	Max power	kW	1,8	
		*Medium cons/hour	kWh	0,9	
		Ampère Max	A/DECK	7,5	
		Connecting cable	AWG/DECK	14	

* This value is subject to variation according to the way in which the equipment is used
NOTE: MORETTI FORNI S.P.A. reserves the right to modify the characteristics of the products illustrated in this publication without prior notice