

INLINE

SERIES



Timeless



**Trusted.
For Life.**



Trusted.
For Life.



PROVEN PERFORMERS

BAY ESPRESSO CAFÉ AT HAWKE'S BAY AIRPORT, NEW ZEALAND - INLINE 5000 SERIES

INLINE

SERIES

Inline cabinets are classic, proven performers.

Complementing any interior design, Inline Series cabinets excel at food presentation to lift sales.

Create an impressive line-up of cabinets to showcase a wide variety of delectable delights: refrigerated, controlled ambient, heated and ambient.

Inline - food display cabinets that stand the test of time.



CAPTIVATE YOUR CUSTOMERS

Create a line-up to impress.

Inline cabinets are designed to work seamlessly together within their Series – 3000, 4000 and 5000. Choose your Series and then choose your profile - curved or square.





Inline Series cabinets include the taller freestanding Tower refrigerated display which maximises product capacity, providing very high visibility on a small footprint.



BP, BALDIVIS, WESTERN AUSTRALIA - INLINE 5000 SERIES

COMPLIANCE ASSURED

Enjoy peace of mind. All FPG cabinets are tested in our environmental test laboratory to deliver core consistent product temperatures:

Cabinet Type	Average Core Product Temperature	Environmental Test Conditions
 Refrigerated	+2°C to +4°C	Climate Class 3: 25°C / 60% RH
 Controlled Ambient	+16°C to +18°C	Climate Class 3: 25°C / 60% RH
 Heated	+65°C to +80°C	22°C / 65% RH
 Ambient	Ambient	Ambient

Inline cabinets are compliant with the international regulations for electrical safety and electromagnetic emissions.

Save more through high energy efficiency

Use less power, reduce your power bills and save money. Inline cabinets are energy efficient. Clever engineering design, technology choices and high material specifications result in lower power consumption. It's good for our planet too.



Trusted.
For Life.

INLINE

OPTIONS TO SUIT YOUR BUSINESS

**Do you serve customers? Or is your business model self-serve?
Inline counter-style cabinets are available in multiple formats
to suit your business:**

- Fixed front for serve-over customer service
- Sliding doors for self-service
- Open front for self-service of pre-packaged food

The Inline Tower Series has a fixed front and is conveniently fitted with two sets of rear sliding doors – upper and lower - for stocking and serving.



INLINE TOWER SERIES, REFRIGERATED, 800mm SQUARE, FREESTANDING, FIXED FRONT.

INLINE

SERIES



INLINE 5000 SERIES, HEATED, 1200mm SQUARE, FREESTANDING - CONFIGURED WITH 4 DISPLAY LEVELS.

L-R: FIXED FRONT, SLIDING DOORS, OPEN FRONT

WHICH INLINE SERIES IS RIGHT FOR YOU?

All Inline cabinets are made to FPG's high standards and deliver core product temperatures, energy efficiency, and extended product shelf life. The table below may help you to determine which Series is right for you.

What are you looking for?	Series	Attributes	Go to page
<p>I am looking for great value.</p> <p>I have small-medium transaction volumes - up to 60 door openings per hour.</p> <p>I need small-medium product capacity.</p> <p>I need a Bain Marie.</p>	Inline 3000	The popular, great value range for small to medium transaction volumes and small-medium capacity.	10
<p>I am looking for great value.</p> <p>I have medium-high transaction volumes - up to 85 door openings per hour.</p> <p>I need medium-large product capacity.</p>	Inline 4000	The great value range for medium to high transaction volumes and high capacity.	12
<p>I want the best.</p> <p>I have high transaction volumes - up to 120 door openings per hour.</p> <p>I have a long-term business horizon >6 years.</p> <p>I need an open front cabinet.</p> <p>Sustainability is important and I want a cabinet that maximises cabinet lifetime.</p>	Inline 5000	The premium range used by corporates to meet high operational demands and support their brand positioning.	14
<p>I want to create a focal point for high value refrigerated product.</p> <p>I have a small footprint and need to maximise vertical display height.</p>	Inline Tower	A freestanding upright refrigerated cabinet for showcasing high value product.	16

INLINE

SERIES



INLINE 4000 SERIES, SQUARE, IN-COUNTER, FIXED FRONT.

L-R: REFRIGERATED 1200mm, CONTROLLED AMBIENT 800mm, HEATED 800mm.

ADDITIONAL SHELF IN HEATED CABINET. THERMAL DIVIDER BETWEEN REFRIGERATED AND CONTROLLED AMBIENT CABINETS.



Trusted.
For Life.

INLINE 3000 SERIES

Created as a small-medium duty solution for cafés, kiosks and c-stores, Inline 3000 Series cabinets are available with curved and square profiles.

They support up to 60 door openings per hour while maintaining core product temperature. Packaged with all the benefits of the FPG Inline cabinet range, you use less energy while maintaining food safety.

The Inline 3000 Series design allows for multiple bench integration options: freestanding, in-counter or on-counter.

The cabinets are constructed from durable stainless steel, mild steel and double-glazed safety glass.



ALFAEXPRESS, INDONESIA - INLINE 3000 SERIES

INLINE

3000 SERIES

CURVED PROFILE

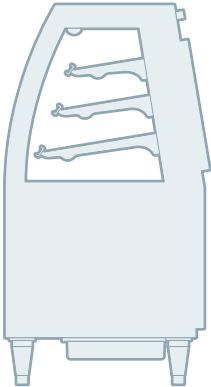

SQUARE PROFILE



FIXED FRONT



CUSTOMER SIDE SLIDING DOORS



BAIN MARIE



FREESTANDING



IN-COUNTER



ON-COUNTER





**Trusted.
For Life.**

INLINE 4000 SERIES

Created for the busy food service business, Inline 4000 Series cabinets are ideal for displaying a large quantity or wide variety of food.

They are proven for 85 door openings an hour while still maintaining core product temperature. The lighting and merchandising features create impact and increase sales. Refrigeration and heating systems are designed to keep product fresher for longer.

The Inline 4000 Series design allows for multiple counter integration options: freestanding, in-counter or on-counter.

The cabinets are constructed from:

- Durable stainless and mild steel with an attractive brushed finish.
- Double-glazed safety glass for energy efficiency and temperature control.



ANGKOR WAT CAFÉ, NEW ZEALAND - INLINE 4000 SERIES

INLINE

4000 SERIES

CURVED PROFILE

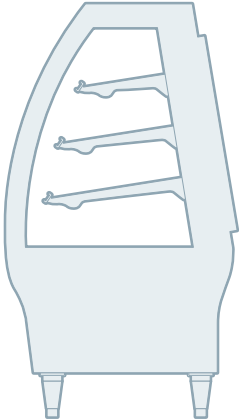

SQUARE PROFILE

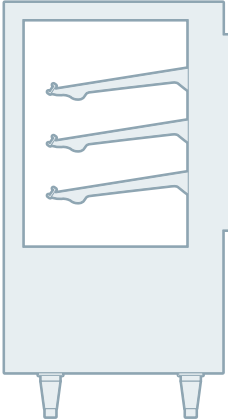

FIXED FRONT



CUSTOMER SIDE SLIDING DOORS



FREESTANDING



IN-COUNTER



ON-COUNTER





**Trusted.
For Life.**

INLINE 5000 SERIES

Our premium range of Inline cabinets is trusted by multi-national customers worldwide.

This heavy-duty cabinet supports up to 120 door openings an hour while still maintaining core product temperature. Increased capacity, robust design and individual shelf lighting enhance product offerings.

The Inline 5000 Series freestanding cabinets are designed to be installed into joinery and support any combination of refrigerated, controlled ambient, heated and ambient line-ups.

The cabinets are constructed from durable stainless steel, mild steel and fully double-glazed safety glass.



HOYTS CINEMA, HAMILTON, NEW ZEALAND - INLINE 5000 SERIES

INLINE

5000 SERIES

CURVED PROFILE

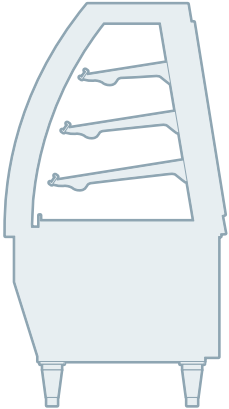

SQUARE PROFILE

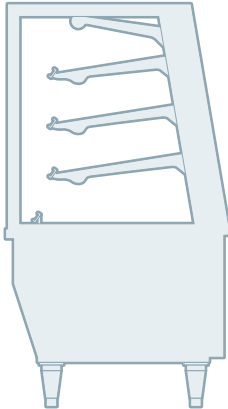

FREESTANDING (IN JOINERY)



FREESTANDING (WITH STAINLESS STEEL CHASSIS SURROUND)



TILT/FIXED FRONT



CUSTOMER SIDE SLIDING DOORS



OPEN FRONT





**Trusted.
For Life.**

INLINE TOWER

The Inline Tower cabinet maximises your refrigerated food and beverage display on a very small footprint – ideal where space is tight.

It provides large capacity and very high visibility which is enhanced with lighting delivered by long-life energy-efficient LEDs. Fitted with an upper and lower rear sliding door system, it's practical and easy to stock and serve.

This high visibility cabinet enhances product appeal to maximise your sales and ensure your product is safe and fresh.

The cabinets are constructed from durable stainless and mild steel. They are finished with a smart black trim which is 'baked' into the fully double-glazed toughened safety glass.



BAKINGTON, NEW DELHI - INLINE TOWER (WITH INLINE 3000 CABINETS)

800mm WIDTH

1200mm WIDTH

SQUARE PROFILE

FIXED FRONT

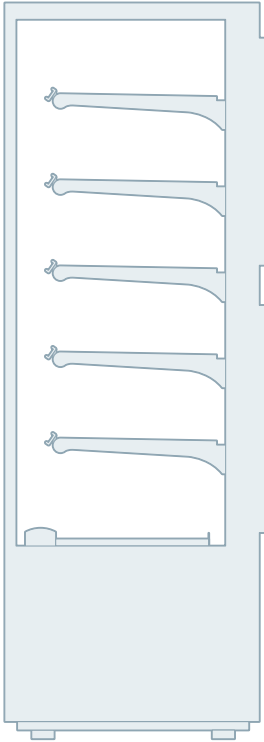

REAR UPPER SLIDING DOORS

REAR LOWER SLIDING DOORS



LIGHT IT UP

The visual appeal of food and drink merchandise is significantly enhanced by our super bright LED lighting which is fitted in all Inline cabinets, including heated cabinets.

With extended lifetimes, the LED lights do not need to be replaced very often:

Refrigerated, Controlled Ambient and Ambient:

50,000 hours

Heated: 25,000 hours

Create a merchandising display that excels in attracting customer attention and supports increased sales.

FPG can help you to explore the options to boost your brand presence and operational efficiency.¹

¹Minimum order quantity may apply



BP DRIVE CAFÉ, BONNYRIGG, AUSTRALIA - INLINE 3000 SERIES WITH LIGHTING TO TOP AND SHELVES (OPTION)

INLINE

SERIES



KINDRED ROAD, NEW ZEALAND - INLINE 3000 SERIES WITH WHITE POWDERCOATED SHELVES

MAKE IT YOUR OWN

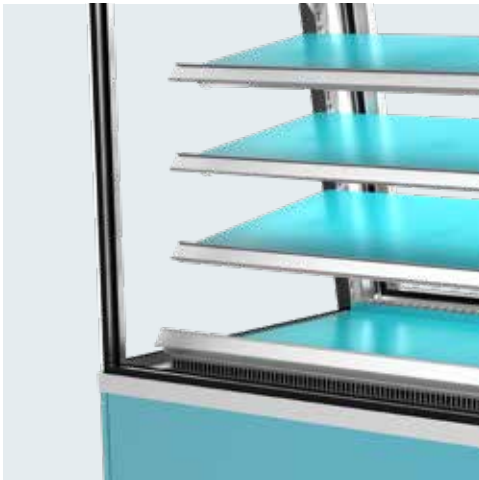

COLOUR

Specify a different colour for the chassis (Freestanding Cabinets) and/or shelves to complement your branding and create impact.
(3000/4000/5000/Tower)



WOODPRINT

Apply woodprint to shelves to create a warmer, visually-appealing display.
(3000/4000/5000/Tower)



SHELF TICKETING

Colour your shelf ticket strips (30mm height) to enhance branding.
(3000/4000/5000/Tower)



MIRROR GLASS

Request mirror glass for the sides and/or cabinet rear to create a fuller looking display and to provide a greater degree of privacy to operations behind the cabinet.
(3000/4000/5000/Tower)



BRANDED INSERTS

Add colour or graphic inserts into our unique aluminium extrusions to boost your brand presence.

(3000 Curved & Square, 4000 Curved)



CHASSIS SURROUND

Request stainless steel chassis panels for cabinets which will not be installed into joinery. (5000)



CUSTOM JOINERY SOLUTION

For self-service, attach a fascia designed to accommodate tongs, bags, and serviettes. (3000/4000/5000 Tower)



BRANDED DECALS

Apply decals to boost your brand presence.

(3000/4000/5000/Tower)

OPERATIONAL FACTORY-FITTED OPTIONS

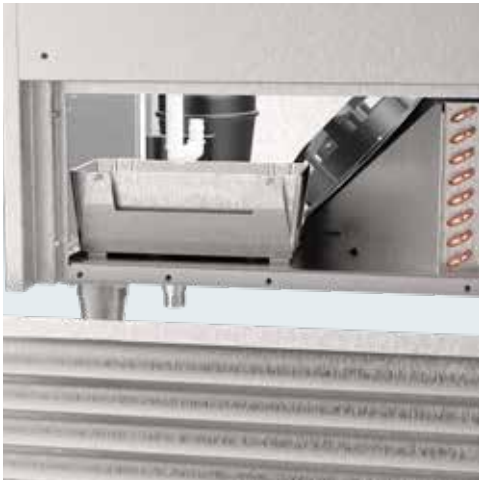

AUTO CONDENSATE REMOVAL

Upgrade to Auto Condensate Removal (ACR) – no more need to manually empty the condensate container. (3000/4000/Tower)*

*ACR is a standard feature on the Inline 5000 Series.



ADDITIONAL SHELF

Expand capacity in heated cabinets by adding an extra shelf. (3000/4000/5000)



ADD A BAIN MARIE SHELF

Add a handy temporary holding shelf in the Bain Marie. (3000)



FOLDING REAR DECK

For serve-over operations, add a folding rear deck with optional inbuilt cavities for bag and tong holders. (5000)
Fixed rear deck. (3000/4000)

INLINE

SERIES



ROLLERS OR CASTORS

If maneuverability is important to you, replace legs with unidirectional rollers or heavy-duty lockable castors. (3000/4000/5000)



FORWARD-FACING CONTROLS

Forward-facing controls and refrigeration venting to the front allow you to install your Inline cabinets against a wall. (3000/4000)



THERMAL DIVIDER PANELS

Installed between adjacent refrigerated/refrigerated, refrigerated/controlled ambient or refrigerated/ambient cabinets to mitigate the potential for condensation. (3000/4000/5000)

There are many opportunities to create a merchandising display that excels in attracting customer attention, supports increased sales, and fits your business model.

Talk to FPG about your needs and wants.



Trusted.
For Life.

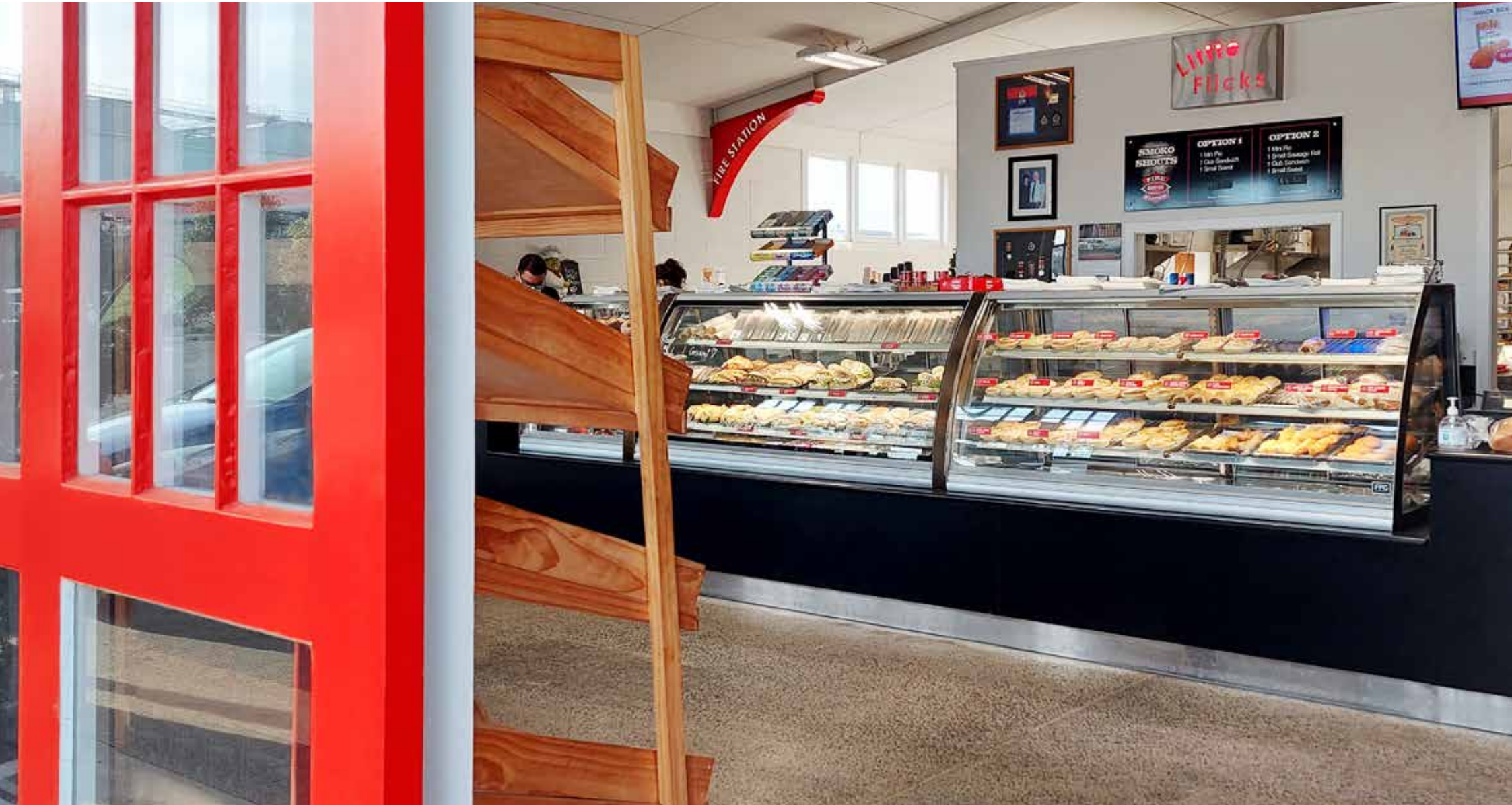

FIRE STATION CAFE, NEW ZEALAND - INLINE 5000 SERIES

TRUSTED FOR LIFE

INLINE
SERIES

Cabinet Lifetime - with regular maintenance and cleaning, extend the lifetime of your Inline cabinet.

- FPG cabinets are constructed from high quality materials and components sourced from reputable suppliers to withstand the rigours of service
- FPG stands by our cabinets for their lifetime – that means spare parts and support will always be available to your technical service providers.

Maintenance & Warranty

For Inline 5000 cabinets with integral refrigeration, regular cleaning of the pre-filter and quarterly preventative maintenance will help to maintain the energy efficiency of the cabinet, extend the life of the cabinet, and keep your warranty valid. Annual service checks of heated and ambient cabinets, and cabinets connected to remote refrigeration systems, are highly recommended to ensure your cabinet is operating optimally.

Well supported

FPG Technical Support is available online and by phone.

We publish online resources to support the service providers of our customers. These include comprehensive manuals, servicing requirements, trouble-shooting, spare parts and 'How To' videos.

We also offer to 'train the trainer' via online platforms.

FPG engineers all cabinets to meet international standards.

International safety standards for electrical refrigerated appliances: IEC 60335-1, IEC 60335-2-89, and the equivalent country-specific standards including AS/NZS and BS EN.

International safety standards for electrical heated appliances: IEC 60335-1, IEC 60335-2-49, IEC 60335-2-50 and the equivalent country-specific standards including AS/NZS and BS EN.

International standards for electromagnetic compatibility/emissions: CISPR 14-1, and the equivalent country-specific standards including AS/NZS CISPR and BS EN 55014-1.

Essential safety requirements: AS/NZS 3820 and AS/NZS 4417.

Energy efficiency for refrigerated appliances: MEPS (Australia/New Zealand).



Some countries permit self-declaration while other countries may require external testing and certificates of conformity.

Please contact us for more information.

QUICK CABINET COMPARISON¹

	INLINE 3000		INLINE 4000		INLINE 5000		TOWER
Profile	Curved	Square	Curved	Square	Curved	Square	Square
Customer Side	Fixed Front Sliding Doors	Fixed Front Sliding Doors	Fixed Front Sliding Doors	Fixed Front Sliding Doors	Tilt Front Sliding Doors Open Front	Fixed Front Tilt Front Sliding Doors Open Front	Fixed Front
Staff Side	Rear sliding doors		Rear sliding doors		Rear sliding doors		Rear sliding doors
Temperature	Refrigerated Controlled Ambient Heated Ambient		Refrigerated Controlled Ambient Heated Ambient		Refrigerated Controlled Ambient Heated Ambient		Refrigerated
Installation Options	Freestanding In-Counter On-Counter		Freestanding In-Counter On-Counter		Freestanding and designed to be installed into joinery		Freestanding
No. of shelves²	3 + base	2 + base	3 + base	3 + base	3 + base	3 + base	5 + base
Bain Marie option?	✓	✓	N/A	N/A	N/A	N/A	N/A
Robustness	Medium duty		Medium duty		Heavy duty		Medium duty

¹This table reflects default configuration of cabinet models.

²Excluding Inline 5000 Open Front cabinets, FPG does not recommend using the base for display of food in heated cabinets due to the proximity to the heating element. Please add a further shelf to expand capacity.

CABINET DIMENSIONS

Width (mm)	CURVED				SQUARE				CURVED OPEN FRONT		SQUARE OPEN FRONT		BAIN MARIE	
	Ref	CA	Heat	Amb	Ref	CA	Heat	Amb	Ref	Heat	Ref	Heat	Curved Heat	Square Heat
600					3	3	3	3						
800	3 4 5	3 4 5	3 4 5	3 4 5	4 5 T	4 5	4 5	4 5	5	5	5	5	3	
900					3	3	3	3						3
1200	3 4 5	3 4 5	3 4 5	3 4 5	3 4 5 T	3 4 5	3 4 5	3 4 5	5	5	5	5	3	3
1500	3 4 5	3 4 5	3 4 5	3 4 5	3 4 5	3 4 5	3 4 5	4 5					3	3
1800	3 4 5	3 4 5	5	5	4 5	4 5	5							
2400	5	5			5	5								

KEY

- 3 Inline 3000
- 4 Inline 4000
- 5 Inline 5000
- T Inline Tower

Ref Refrigerated +2°C - +4°C

CA Controlled Ambient +16°C - +18°C

Heat Heated +65°C - +80°C

Amb Ambient

All measurements are rounded. Please consult the specification sheet for further information on your chosen Inline Series cabinet(s) available from www.fpgwprld.com or talk to your FPG representative.



**Trusted.
For Life.**



HOSPITALITY



SPECIALITY
FOOD SERVICE



C-STORE



CAFÉ/BAKERY
QSR



SUPERMARKET



FMCG



Worldwide
contact
details:



fpgworld.com
sales@fpgworld.com