



Modular electric deck oven

2 decks composition

serieP consists of one or more independent baking chambers and an optional proofer or stand. The baking surface is made of refractory stone with coiled heating elements inside, allowing the perfect heat distribution over the whole surface. This oven is particularly suitable for direct pizza baking, on floor or on trays. Embossed stainless steel surface combined with steamer (optional) is available as an alternative to refractory stone and it is especially recommended for bakery. The baking chamber comes in two heights: 18cm or 30 cm. Temperature management is electronic, power control of ceiling and floor is independent. The oven door is hinged at the bottom, with a tempered glass window to check the product during baking. The stand consists of a painted metal structure, while the proofer is a stainless steel cabinet equipped with a heating thermostat. The proofer can reach the maximum temperature of 65°C (149°F), whereas the maximum temperature of the baking chamber is 450°C (842°F).



OPERATION

- Heated by armoured heating elements
- Electronic temperature management with independent adjustment of ceiling and floor
- Maximum temperature reached 450°C (842°F)
- Continuous temperatures monitoring in baking chamber by thermocouple
- Vapour ducting using manual butterfly valve

CONSTRUCTION

- Structure made in folded stainless steel
- Side panels in painted sheet metal
- Hood in stainless steel
- Steam duct in stainless steel plate
- Stainless steel door, tempered glass
- Aluminated steel top and side structure
- Dual halogen lighting
- Rock wool heat insulation

ACCESSORIES

- Leavening proofer on wheels height 600, 800mm
- Stand with wheels height 600, 800, 950mm
- Steamer
- Spacer element height 300mm
- Refractory brick or buckle plate surface
- Additional tray holder guides for compartment and stand
- Motor for hood vapours extraction 500 m3/h
- Self-condensing hood
- Frontless hood

INTERNAL BAKING DIMENSIONS

Internal height	180-300mm
Internal depth	1230mm
Internal width	805mm
Baking surface	1m ²

STANDARD EQUIPMENT

- 20 customisable programs
- Timer
- Economiser
- Independent maximum temperature safety device

TOP VIEW

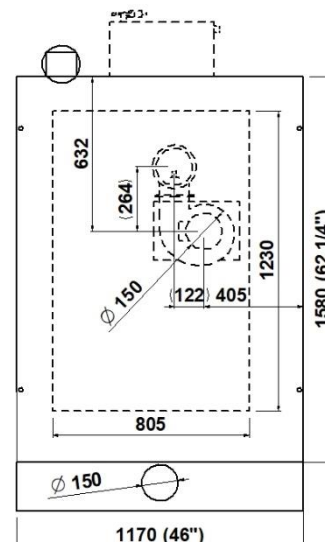

1 baking chamber height 18cm

(assembled with stand height 950mm)

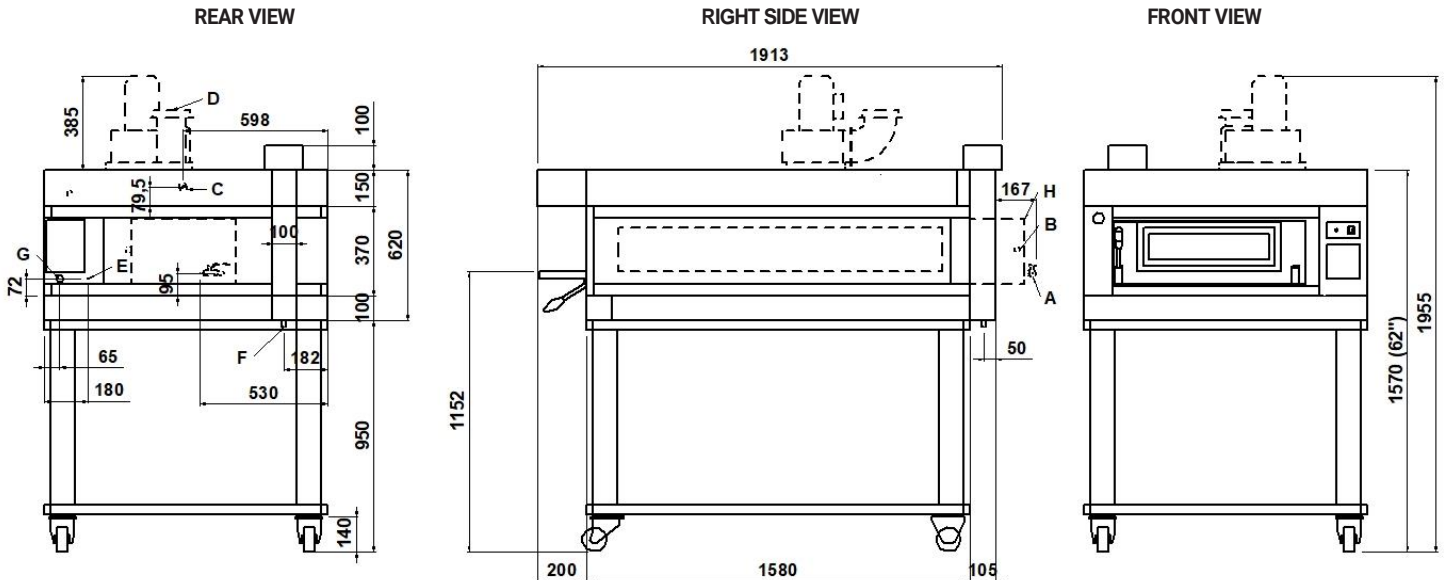

NOTE: The dimensions indicated in the views are in millimeters.

A Ø8 steamer water outlet	B 3/4" male steamer water inlet	C Ø16 hood condensate exhaust	D Ø150 steam exhaust
E M6 equipotential screws	F Ø12 condensate exhaust	G fairleads	H Steamer 1600W (see data sheet)

DIMENSIONS

External height	620mm
External depth	1941mm
External width	1170mm
Weight	211kg

TOTAL BAKING CAPACITY

Tray (600x400)mm	4
Pizza diameter 300mm	9
Pizza diameter 450mm	3

SHIPPING INFORMATION

Packed in wooden crate	
Height	870mm
Depth	2141mm
Width	1370mm
Weight	(211+50)kg

When combined with leavening compartment or stand:	
Max height	1820mm
Max weight	(305+60)kg

FEEDING AND POWER

Standard feeding	
A.C. V400 3N	
Feeding on request	
A.C. V230 3	
Frequency	50/60Hz
Max power	11kW
*Average power cons	5,5kWh
Connecting cable for each chamber	
type H07RN-F	
5x4mm ² (V400 3N)	
4x6mm ² (V230 3)	
Power supply (optional prover)	
A.C. V230 1N 50/60 Hz	
Max power	1,5kW
*Average power cons	0,8kWh
Conn. Cable type H07RN-F	3x1,5mm ²

* This value is subject to variation according to the way in which the equipment is used

NOTE: MORETTI FORNI S.P.A. reserves the right to modify the characteristics of the products illustrated in this publication without prior notice

2 baking chambers height 18cm

(assembled with prover height 800mm)

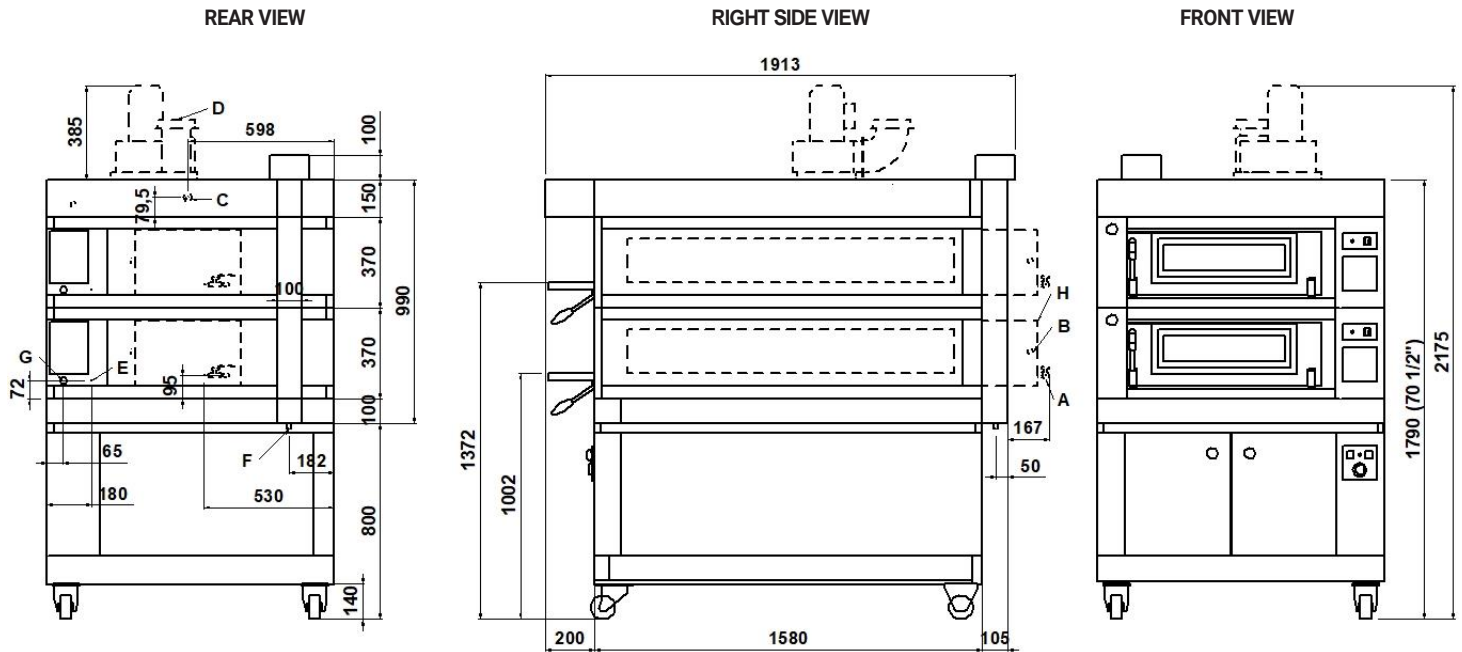

NOTE: The dimensions indicated in the views are in millimeters.

A Ø8 steamer water outlet	B 3/4" male steamer water inlet	C Ø16 Hood condensate exhaust	D Ø150 steam exhaust
E M6 equipotential screws	F Ø12 condensate exhaust	G fairleads	H Steamer 1600W (see data sheet)

DIMENSIONS

External height	990mm
External depth	1941mm
External width	1170mm
Weight	347kg

SHIPPING INFORMATION

Packed in wooden crate	
Height	1240mm
Depth	2141mm
Width	1370mm
Weight	(347+60)kg

FEEDING AND POWER

Standard feeding	
A.C. V400 3N	
Feeding on request	
A.C. V230 3	
Frequency	50/60Hz
Max power	22kW
*Average power cons	11kW
Connecting cable for each chamber	
type H07RN-F	
5x4mm ² (V400 3N)	
4x6mm ² (V230 3)	
Power supply (optional prover)	
A.C. V230 1N 50/60 Hz	
Max power	1,5kW
*Average power cons	0,8kWh
Conn. Cable type H07RN-F	3x1,5mm ²

TOTAL BAKING CAPACITY

Tray (600x400)mm	8	When combined with leavening compartment or stand:
Pizza diameter 300mm	18	Max height
Pizza diameter 450mm	6	Max weight

* This value is subject to variation according to the way in which the equipment is used

NOTE: MORETTI FORNI S.P.A. reserves the right to modify the characteristics of the products illustrated in this publication without prior notice

3 baking chambers height 18cm
(assembled with prover height 600mm)

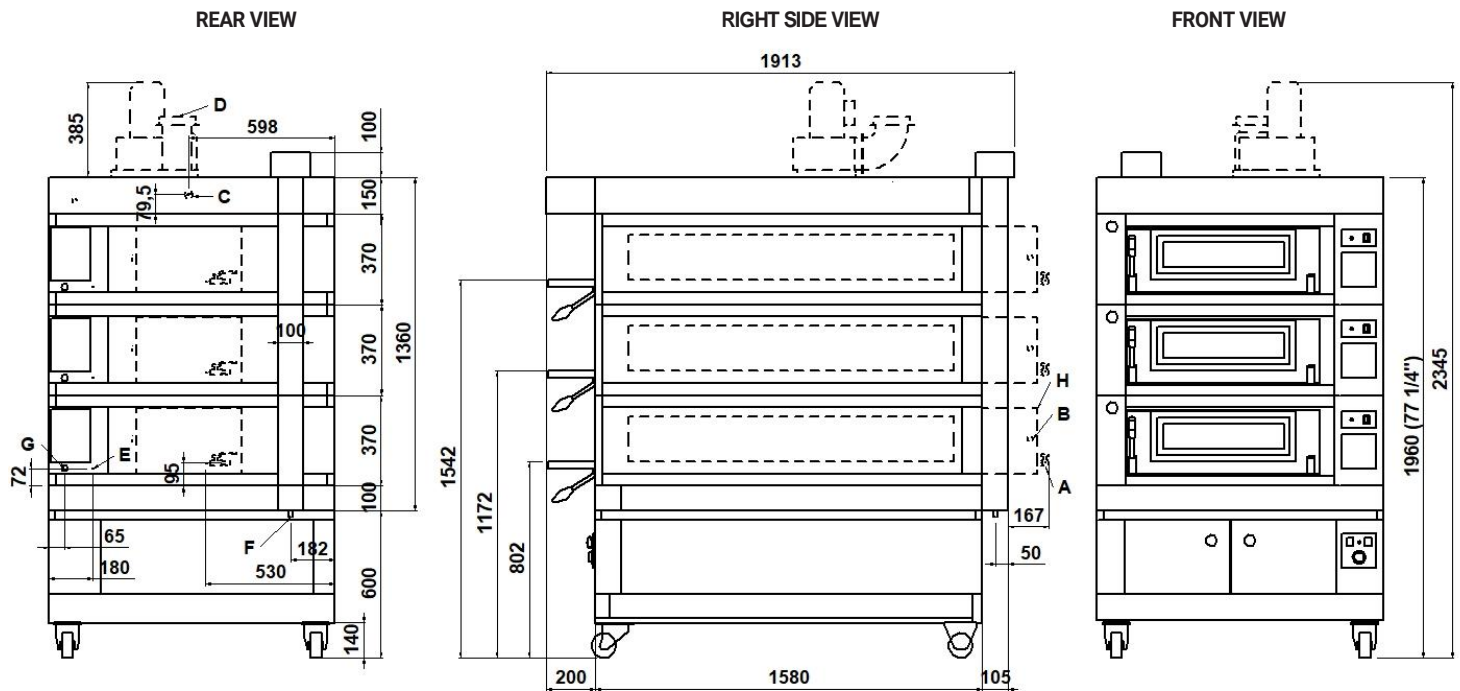

NOTE: The dimensions indicated in the views are in millimeters.

A Ø8 steamer water outlet	B 3/4" male steamer water inlet	C Ø16 Hood condensate exhaust	D Ø150 steam exhaust
E M6 equipotential screws	F Ø12 condensate exhaust	G fairleads	H Steamer 1600W (see data sheet)

DIMENSIONS

External height	1360mm
External depth	1941mm
External width	1170mm
Weight	483kg

SHIPPING INFORMATION

Packed in wooden crate	
Height	1610mm
Depth	2141mm
Width	1370mm
Weight	(483+70)kg

FEEDING AND POWER

Standard feeding	
A.C. V400 3N	
Feeding on request	
A.C. V230 3	
Frequency	50/60Hz
Max power	33kW
*Average power cons	16,5kWh
Connecting cable for each chamber	
type H07RN-F	
5x4mm ² (V400 3N)	
4x6mm ² (V230 3)	
Power supply (optional prover)	
A.C. V230 1N 50/60 Hz	
Max power	1,5kW
*Average power cons	0,8kWh
Conn. Cable type H07RN-F 3x1,5mm ²	

TOTAL BAKING CAPACITY

Tray (600x400)mm	12	When combined with leavening compartment or stand:
Pizza diameter 300mm	27	Max height
Pizza diameter 450mm	9	Max weight

* This value is subject to variation according to the way in which the equipment is used
NOTE: MORETTI FORNI S.P.A. reserves the right to modify the characteristics of the products illustrated in this publication without prior notice

2 baking chambers height 18+30 cm
(assembled with prover height 800mm)

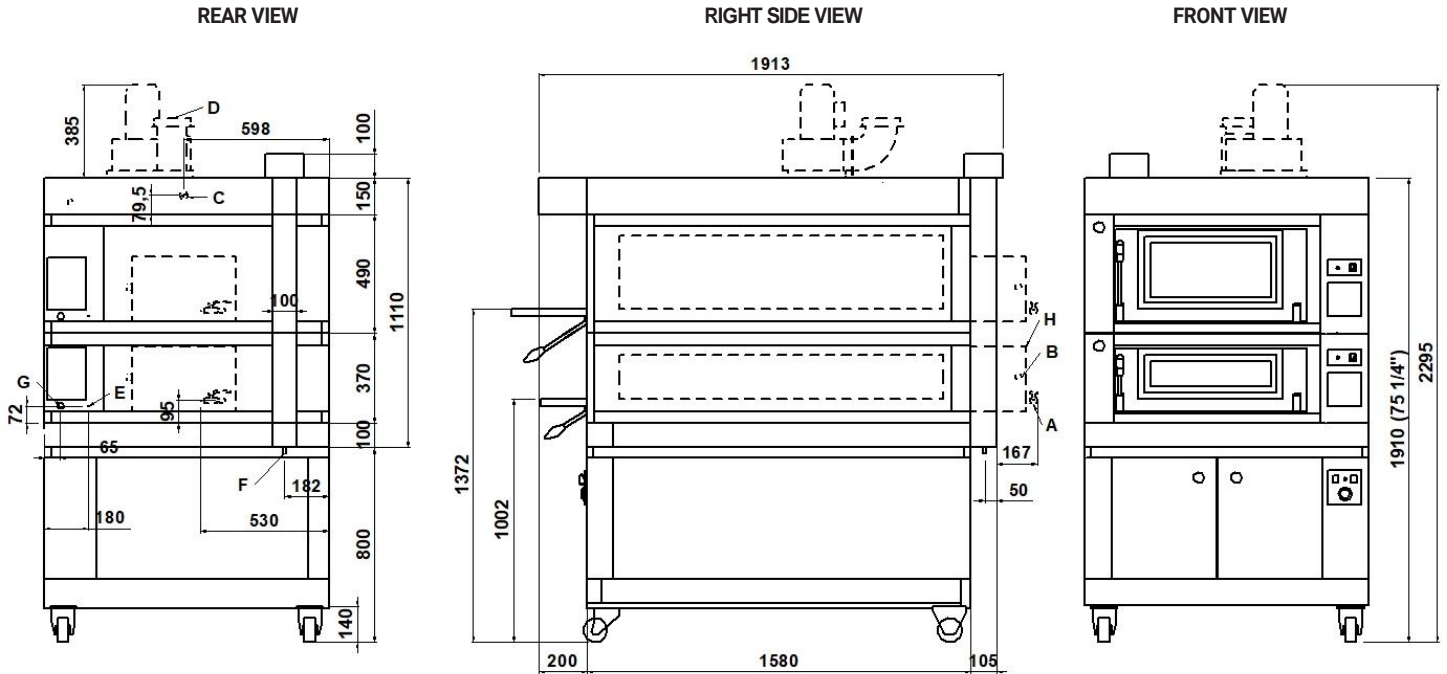

NOTE: The dimensions indicated in the views are in millimeters.

A Ø8 steamer water outlet	B 3/4" male steamer water inlet	C Ø16 Hood condensate exhaust	D Ø150 steam exhaust
E M6 equipotential screws	F Ø12 condensate exhaust	G fairleads	H Steamer 1600W (see data sheet)

DIMENSIONS

External height	1110mm
External depth	1941mm
External width	1170mm
Weight	370kg

TOTAL BAKING CAPACITY

Tray (600x400)mm	8
Pizza diameter 300mm	18
Pizza diameter 450mm	6

SHIPPING INFORMATION

Packed in wooden crate	
Height	1360mm
Depth	2141mm
Width	1370mm
Weight	(370+60)kg

When combined with leavening compartment or stand:	
Max height	2320mm
Max weight	(470+70)kg

FEEDING AND POWER

Standard feeding	
A.C. V400 3N	
Feeding on request	
A.C. V230 3	
Frequency	50/60Hz
Max power	22kW
*Average power cons	22kWh
Connecting cable for each chamber	
type H07RN-F	
5x4mm ² (V400 3N)	
4x6mm ² (V230 3)	
Power supply (optional prover)	
A.C. V230 1N 50/60 Hz	
Max power	1,5kW
*Average power cons	0,8kWh
Conn. Cable type H07RN-F 3x1,5mm ²	

* This value is subject to variation according to the way in which the equipment is used
NOTE: MORETTI FORNI S.P.A. reserves the right to modify the characteristics of the products illustrated in this publication without prior notice

3 baking chambers height 18+18+30 cm
(assembled with stand prover 600mm)

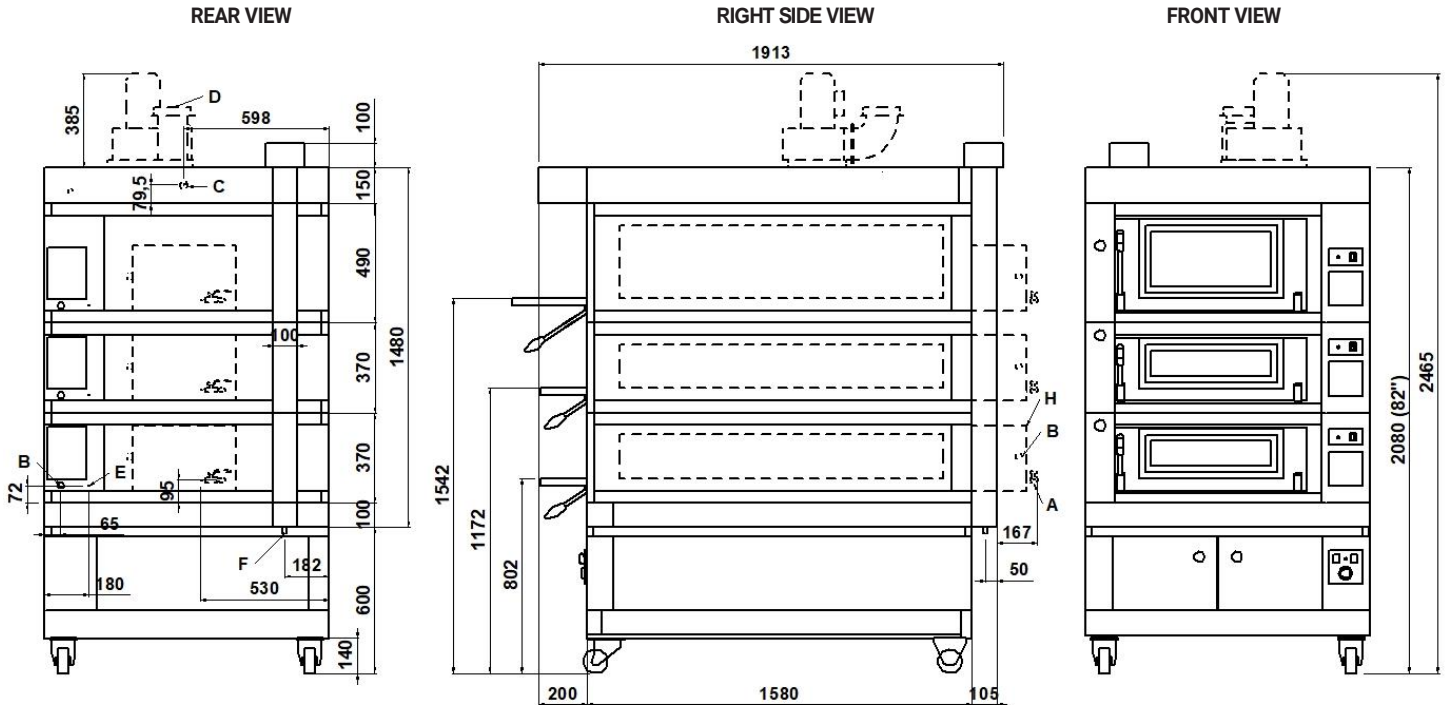

NOTE: The dimensions indicated in the views are in millimeters.

A Ø8 steamer water outlet	B 3/4" male steamer water inlet	C Ø16 Hood condensate exhaust	D Ø150 steam exhaust
E M6 equipotential screws	F Ø12 condensate exhaust	G fairleads	H Steamer 1600W (see data sheet)

DIMENSIONS

External height	1480mm
External depth	1941mm
External width	1170mm
Weight	505kg

SHIPPING INFORMATION

Packed in wooden crate	
Height	1730mm
Depth	2141mm
Width	1370mm
Weight	(505+70)kg

FEEDING AND POWER

Standard feeding	
A.C. V400 3N	
Feeding on request	
A.C. V230 3	
Frequency	50/60Hz
Max power	33kW
*Average power cons	16,5kWh
Connecting cable for each chamber	
type H07RN-F	
5x4mm ² (V400 3N)	
4x6mm ² (V230 3)	
Power supply (optional prover)	
A.C. V230 1N 50/60 Hz	
Max power	1,5kW
*Average power cons	0,8kWh
Conn. Cable type H07RN-F 3x1,5mm ²	

TOTAL BAKING CAPACITY

Tray (600x400)mm	12	When combined with leavening compartment or stand:
Pizza diameter 300mm	27	Max height
Pizza diameter 450mm	9	Max weight

* This value is subject to variation according to the way in which the equipment is used

NOTE: MORETTI FORNI S.P.A. reserves the right to modify the characteristics of the products illustrated in this publication without prior notice

P80

TECHNICAL DATA

SHIPPING INFORMATION H18		P80_1_18	P80_2_18	P80_3_18
Packed in wooden crate	Height	870mm	1240mm	1610mm
	Weight	(211+50)kg	(347+60)kg	(483+70)kg
When combined with prover or stand	Max. height	1820mm	2200mm	2560mm
	Max. weight	(305+60)kg	(441+70)kg	(570+80)kg
SHIPPING INFORMATION H30		P80_1_30	P80_2_30	P80_3_30
Packed in wooden crate	Height	990mm	1480mm	1970mm
	Weight	(225+50)kg	(375+60)kg	(525+70)kg
When combined with prover or stand	Max. height	1940mm	2440mm	2920mm
	Max. weight	(319+60)kg	(469+70)kg	(612+80)kg

FEEDING AND POWER (REFERRED TO 1 BAKING CHAMBER)	Max power	Pizzeria	kW	11
	*Average power consumption		kWh	5,5
	Max power	Pastry	kW	8,5
	*Average power consumption		kWh	4,3
	Max power	Boosted heating elements	kW	10,2
	*Average power consumption		kWh	5,1

* This value is subject to variation according to the way in which the equipment is used

NOTE: MORETTI FORNI S.P.A. reserves the right to modify the characteristics of the products illustrated in this publication without prior notice



Modular electric deck oven

2 decks composition

serieP consists of one or more independent baking chambers and an optional proofer or stand. The baking surface is made of refractory stone with coiled heating elements inside, allowing the perfect heat distribution over the whole surface. This oven is particularly suitable for direct pizza baking, on floor or on trays. Embossed stainless steel surface combined with steamer (optional) is available as an alternative to refractory stone and it is especially recommended for bakery. The baking chamber comes in two heights: 18cm or 30 cm. Temperature management is electronic, power control of ceiling and floor is independent. The oven door is hinged at the bottom, with a tempered glass window to check the product during baking. The stand consists of a painted metal structure, while the proofer is a stainless steel cabinet equipped with a heating thermostat. The proofer can reach the maximum temperature of 65°C (149°F), whereas the maximum temperature of the baking chamber is 450°C (842°F).



OPERATION

- Heated by armoured heating elements
- Electronic temperature management with independent adjustment of ceiling and floor
- Maximum temperature reached 450°C (842°F)
- Continuous temperatures monitoring in baking chamber by thermocouple
- Vapour ducting using manual butterfly valve

CONSTRUCTION

- Structure made in folded stainless steel
- Side panels in painted sheet metal
- Hood in stainless steel
- Steam duct in stainless steel plate
- Stainless steel door, tempered glass
- Aluminated steel top and side structure
- Dual halogen lighting
- Rock wool heat insulation

ACCESSORIES

- Leavening proofer on wheels height 600, 800mm
- Stand with wheels height 600, 800, 950mm
- Steamer
- Spacer element height 300mm
- Refractory brick or buckle plate surface
- Additional tray holder guides for compartment and stand
- Motor for hood vapours extraction 500 m3/h
- Self-condensing hood
- Frontless hood

INTERNAL BAKING DIMENSIONS

Internal height	180-300mm
Internal depth	1230mm
Internal width	805mm
Baking surface	1m ²

STANDARD EQUIPMENT

- 20 customisable programs
- Timer
- Economiser
- Independent maximum temperature safety device

TOP VIEW

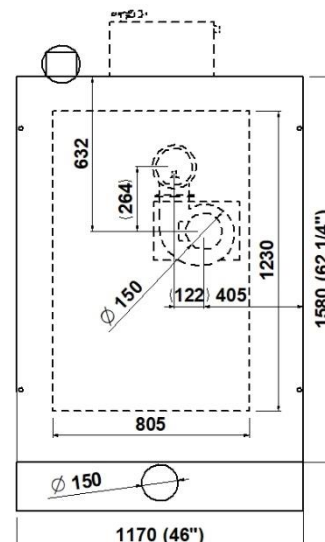

1 baking chamber height 18cm

(assembled with stand height 950mm)

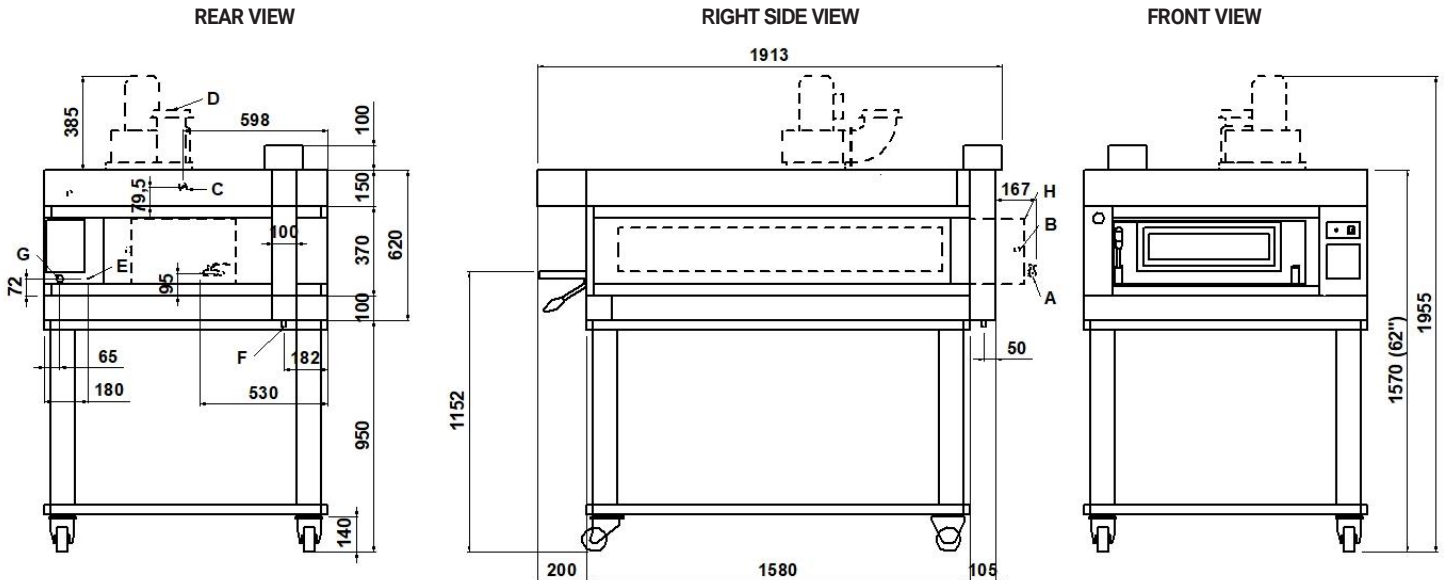

NOTE: The dimensions indicated in the views are in millimeters.

A Ø8 steamer water outlet	B 3/4" male steamer water inlet	C Ø16 hood condensate exhaust	D Ø150 steam exhaust
E M6 equipotential screws	F Ø12 condensate exhaust	G fairleads	H Steamer 1600W (see data sheet)

DIMENSIONS

External height	620mm
External depth	1941mm
External width	1170mm
Weight	211kg

SHIPPING INFORMATION

Packed in wooden crate	
Height	870mm
Depth	2141mm
Width	1370mm
Weight	(211+50)kg

FEEDING AND POWER

Standard feeding	
A.C. V400 3N	
Feeding on request	
A.C. V230 3	
Frequency	50/60Hz
Max power	11kW
*Average power cons	5,5kWh
Connecting cable for each chamber	
type H07RN-F	
5x4mm ² (V400 3N)	
4x6mm ² (V230 3)	
Power supply (optional prover)	
A.C. V230 1N 50/60 Hz	
Max power	1,5kW
*Average power cons	0,8kWh
Conn. Cable type H07RN-F	3x1,5mm ²

TOTAL BAKING CAPACITY

Tray (600x400)mm	4	When combined with leavening
Pizza diameter 300mm	9	compartment or stand:
Pizza diameter 450mm	3	Max height
		Max weight

* This value is subject to variation according to the way in which the equipment is used
NOTE: MORETTI FORNI S.P.A. reserves the right to modify the characteristics of the products illustrated in this publication without prior notice

2 baking chambers height 18cm

(assembled with prover height 800mm)

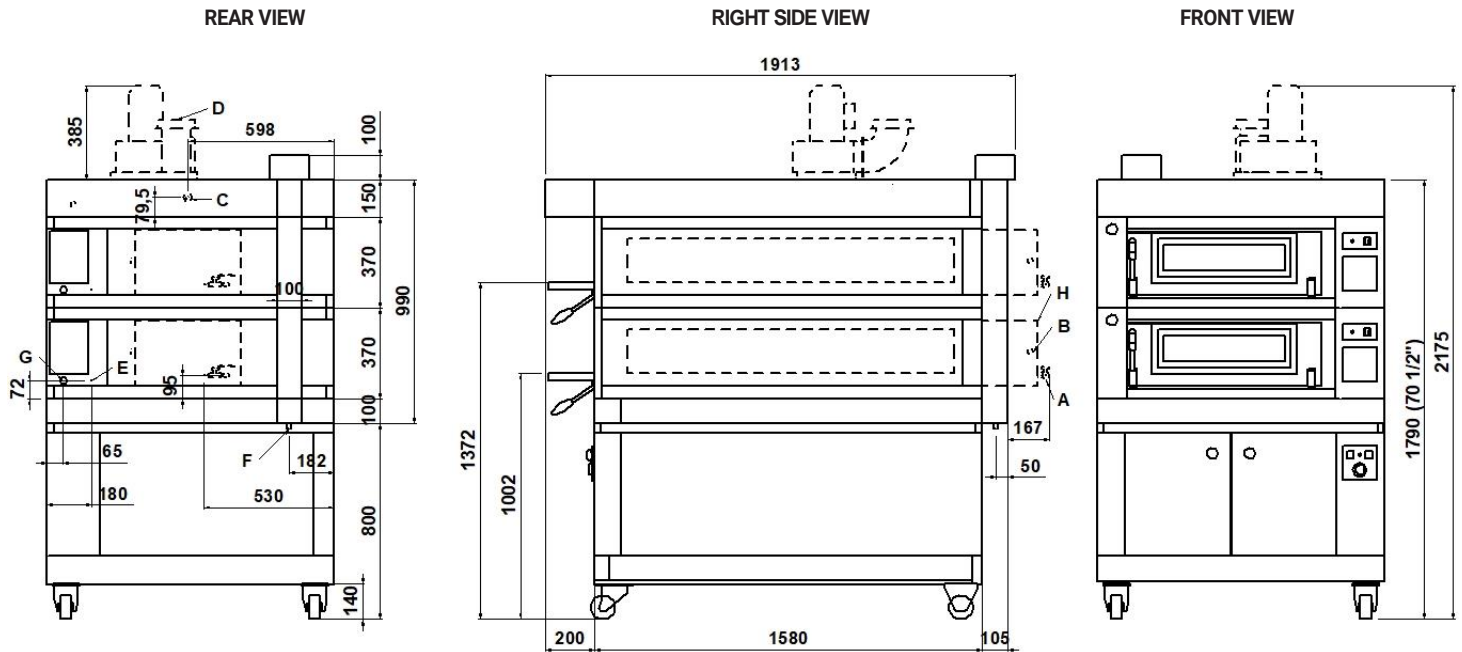

NOTE: The dimensions indicated in the views are in millimeters.

A Ø8 steamer water outlet	B 3/4" male steamer water inlet	C Ø16 Hood condensate exhaust	D Ø150 steam exhaust
E M6 equipotential screws	F Ø12 condensate exhaust	G fairleads	H Steamer 1600W (see data sheet)

DIMENSIONS

External height	990mm
External depth	1941mm
External width	1170mm
Weight	347kg

SHIPPING INFORMATION

Packed in wooden crate	
Height	1240mm
Depth	2141mm
Width	1370mm
Weight	(347+60)kg

FEEDING AND POWER

Standard feeding	
A.C. V400 3N	
Feeding on request	
A.C. V230 3	
Frequency	50/60Hz
Max power	22kW
*Average power cons	11kW
Connecting cable for each chamber	
type H07RN-F	
5x4mm ² (V400 3N)	
4x6mm ² (V230 3)	
Power supply (optional prover)	
A.C. V230 1N 50/60 Hz	
Max power	1,5kW
*Average power cons	0,8kWh
Conn. Cable type H07RN-F	3x1,5mm ²

TOTAL BAKING CAPACITY

Tray (600x400)mm	8	When combined with leavening
Pizza diameter 300mm	18	compartment or stand:
Pizza diameter 450mm	6	Max height
		Max weight

* This value is subject to variation according to the way in which the equipment is used

NOTE: MORETTI FORNI S.P.A. reserves the right to modify the characteristics of the products illustrated in this publication without prior notice

3 baking chambers height 18cm
(assembled with prover height 600mm)

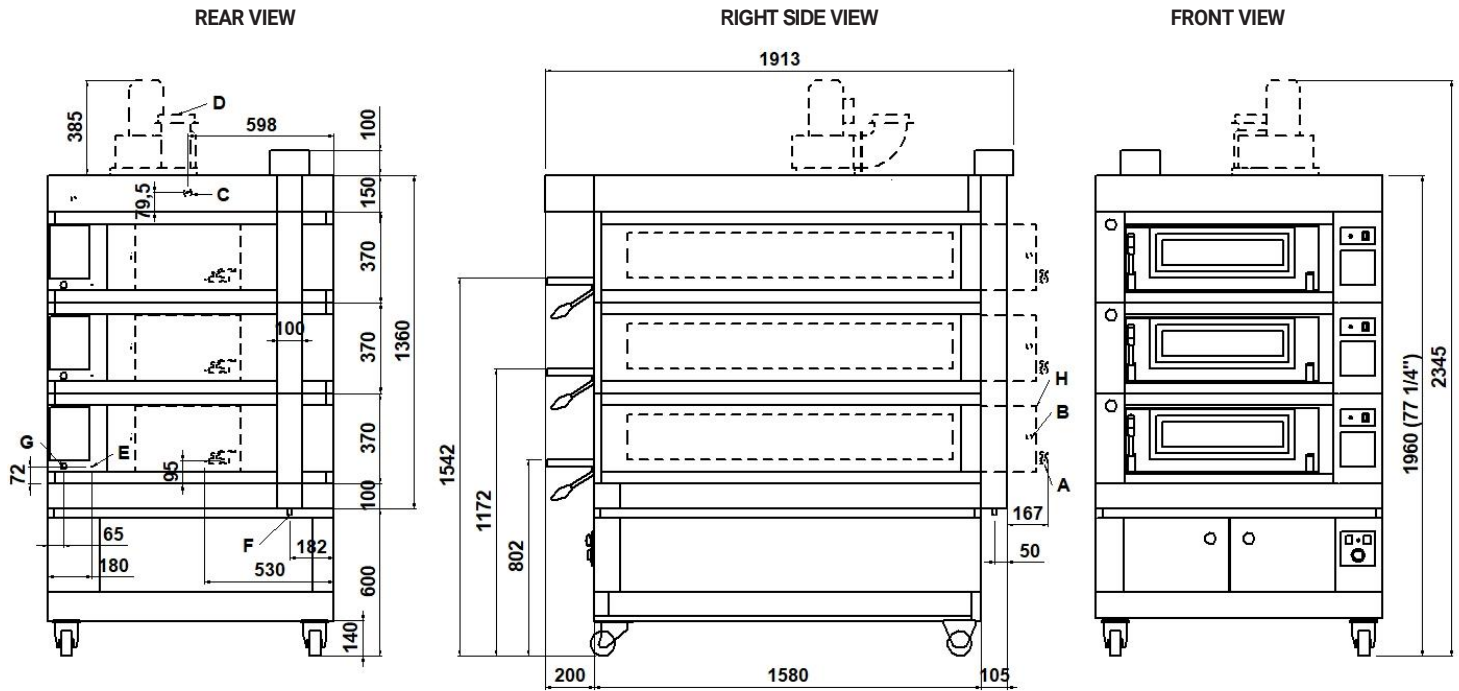

NOTE: The dimensions indicated in the views are in millimeters.

A Ø8 steamer water outlet	B 3/4" male steamer water inlet	C Ø16 Hood condensate exhaust	D Ø150 steam exhaust
E M6 equipotential screws	F Ø12 condensate exhaust	G fairleads	H Steamer 1600W (see data sheet)

DIMENSIONS

External height	1360mm
External depth	1941mm
External width	1170mm
Weight	483kg

SHIPPING INFORMATION

Packed in wooden crate	
Height	1610mm
Depth	2141mm
Width	1370mm
Weight	(483+70)kg

FEEDING AND POWER

Standard feeding	
A.C. V400 3N	
Feeding on request	
A.C. V230 3	
Frequency	50/60Hz
Max power	33kW
*Average power cons	16,5kWh
Connecting cable for each chamber	
type H07RN-F	
5x4mm ² (V400 3N)	
4x6mm ² (V230 3)	
Power supply (optional prover)	
A.C. V230 1N 50/60 Hz	
Max power	1,5kW
*Average power cons	0,8kWh
Conn. Cable type H07RN-F 3x1,5mm ²	

TOTAL BAKING CAPACITY

Tray (600x400)mm	12	When combined with leavening compartment or stand:
Pizza diameter 300mm	27	Max height
Pizza diameter 450mm	9	Max weight

* This value is subject to variation according to the way in which the equipment is used

NOTE: MORETTI FORNI S.P.A. reserves the right to modify the characteristics of the products illustrated in this publication without prior notice

2 baking chambers height 18+30 cm
(assembled with prover height 800mm)

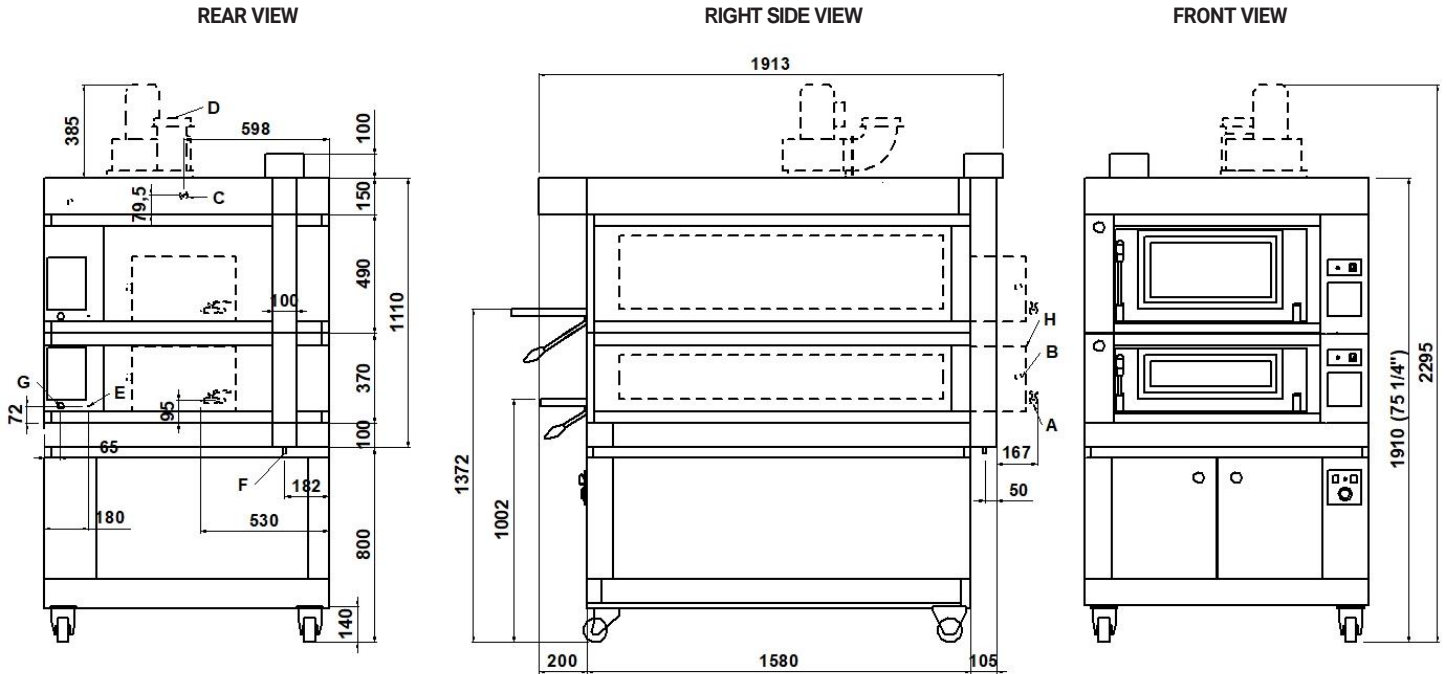

NOTE: The dimensions indicated in the views are in millimeters.

A Ø8 steamer water outlet	B 3/4" male steamer water inlet	C Ø16 Hood condensate exhaust	D Ø150 steam exhaust
E M6 equipotential screws	F Ø12 condensate exhaust	G fairleads	H Steamer 1600W (see data sheet)

DIMENSIONS

External height	1110mm
External depth	1941mm
External width	1170mm
Weight	370kg

TOTAL BAKING CAPACITY

Tray (600x400)mm	8
Pizza diameter 300mm	18
Pizza diameter 450mm	6

SHIPPING INFORMATION

Packed in wooden crate	
Height	1360mm
Depth	2141mm
Width	1370mm
Weight	(370+60)kg

When combined with leavening compartment or stand:	
Max height	2320mm
Max weight	(470+70)kg

FEEDING AND POWER

Standard feeding	
A.C. V400 3N	
Feeding on request	
A.C. V230 3	
Frequency	50/60Hz
Max power	22kW
*Average power cons	22kWh
Connecting cable for each chamber	
type H07RN-F	
5x4mm ² (V400 3N)	
4x6mm ² (V230 3)	
Power supply (optional prover)	
A.C. V230 1N 50/60 Hz	
Max power	1,5kW
*Average power cons	0,8kWh
Conn. Cable type H07RN-F 3x1,5mm ²	

* This value is subject to variation according to the way in which the equipment is used
NOTE: MORETTI FORNI S.P.A. reserves the right to modify the characteristics of the products illustrated in this publication without prior notice

3 baking chambers height 18+18+30 cm
(assembled with stand prover 600mm)

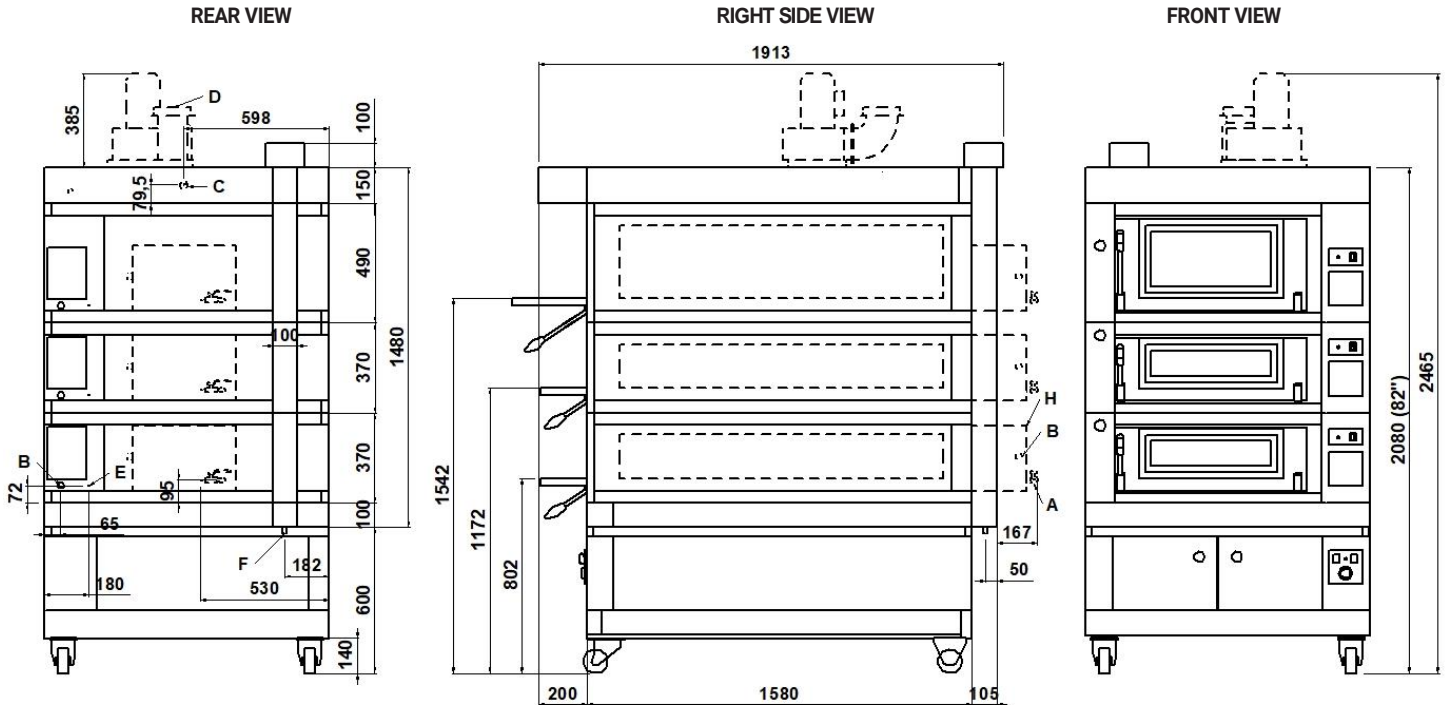

NOTE: The dimensions indicated in the views are in millimeters.

A Ø8 steamer water outlet	B 3/4" male steamer water inlet	C Ø16 Hood condensate exhaust	D Ø150 steam exhaust
E M6 equipotential screws	F Ø12 condensate exhaust	G fairleads	H Steamer 1600W (see data sheet)

DIMENSIONS

External height	1480mm
External depth	1941mm
External width	1170mm
Weight	505kg

SHIPPING INFORMATION

Packed in wooden crate	
Height	1730mm
Depth	2141mm
Width	1370mm
Weight	(505+70)kg

FEEDING AND POWER

Standard feeding	
A.C. V400 3N	
Feeding on request	
A.C. V230 3	
Frequency	50/60Hz
Max power	33kW
*Average power cons	16,5kWh
Connecting cable for each chamber	
type H07RN-F	
5x4mm ² (V400 3N)	
4x6mm ² (V230 3)	
Power supply (optional prover)	
A.C. V230 1N 50/60 Hz	
Max power	1,5kW
*Average power cons	0,8kWh
Conn. Cable type H07RN-F 3x1,5mm ²	

TOTAL BAKING CAPACITY

Tray (600x400)mm	12	When combined with leavening compartment or stand:
Pizza diameter 300mm	27	Max height
Pizza diameter 450mm	9	Max weight

* This value is subject to variation according to the way in which the equipment is used

NOTE: MORETTI FORNI S.P.A. reserves the right to modify the characteristics of the products illustrated in this publication without prior notice

P80

TECHNICAL DATA

SHIPPING INFORMATION H18		P80_1_18	P80_2_18	P80_3_18
Packed in wooden crate	Height	870mm	1240mm	1610mm
	Weight	(211+50)kg	(347+60)kg	(483+70)kg
When combined with prover or stand	Max. height	1820mm	2200mm	2560mm
	Max. weight	(305+60)kg	(441+70)kg	(570+80)kg
SHIPPING INFORMATION H30		P80_1_30	P80_2_30	P80_3_30
Packed in wooden crate	Height	990mm	1480mm	1970mm
	Weight	(225+50)kg	(375+60)kg	(525+70)kg
When combined with prover or stand	Max. height	1940mm	2440mm	2920mm
	Max. weight	(319+60)kg	(469+70)kg	(612+80)kg

FEEDING AND POWER (REFERRED TO 1 BAKING CHAMBER)	Max power	Pizzeria	kW	11
	*Average power consumption		kWh	5,5
	Max power	Pastry	kW	8,5
	*Average power consumption		kWh	4,3
	Max power	Boosted heating elements	kW	10,2
	*Average power consumption		kWh	5,1

* This value is subject to variation according to the way in which the equipment is used

NOTE: MORETTI FORNI S.P.A. reserves the right to modify the characteristics of the products illustrated in this publication without prior notice



Modular electric deck oven

2 decks composition

serieP consists of one or more independent baking chambers and an optional proofer or stand. The baking surface is made of refractory stone with coiled heating elements inside, allowing the perfect heat distribution over the whole surface. This oven is particularly suitable for direct pizza baking, on floor or on trays. Embossed stainless steel surface combined with steamer (optional) is available as an alternative to refractory stone and it is especially recommended for bakery. The baking chamber comes in two heights: 18cm or 30 cm. Temperature management is electronic, power control of ceiling and floor is independent. The oven door is hinged at the bottom, with a tempered glass window to check the product during baking. The stand consists of a painted metal structure, while the proofer is a stainless steel cabinet equipped with a heating thermostat. The proofer can reach the maximum temperature of 65°C (149°F), whereas the maximum temperature of the baking chamber is 450°C (842°F).



OPERATION

- Heated by armoured heating elements
- Electronic temperature management with independent adjustment of ceiling and floor
- Maximum temperature reached 450°C (842°F)
- Continuous temperatures monitoring in baking chamber by thermocouple
- Vapour ducting using manual butterfly valve

CONSTRUCTION

- Structure made in folded stainless steel
- Side panels in painted sheet metal
- Hood in stainless steel
- Steam duct in stainless steel plate
- Stainless steel door, tempered glass
- Aluminated steel top and side structure
- Dual halogen lighting
- Rock wool heat insulation

ACCESSORIES

- Leavening proofer on wheels height 600, 800mm
- Stand with wheels height 600, 800, 950mm
- Steamer
- Spacer element height 300mm
- Refractory brick or buckle plate surface
- Additional tray holder guides for compartment and stand
- Motor for hood vapours extraction 500 m3/h
- Self-condensing hood
- Frontless hood

INTERNAL BAKING DIMENSIONS

Internal height	180-300mm
Internal depth	1230mm
Internal width	805mm
Baking surface	1m ²

STANDARD EQUIPMENT

- 20 customisable programs
- Timer
- Economiser
- Independent maximum temperature safety device

TOP VIEW

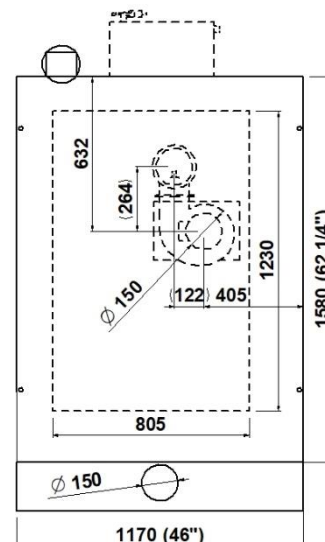

1 baking chamber height 18cm

(assembled with stand height 950mm)

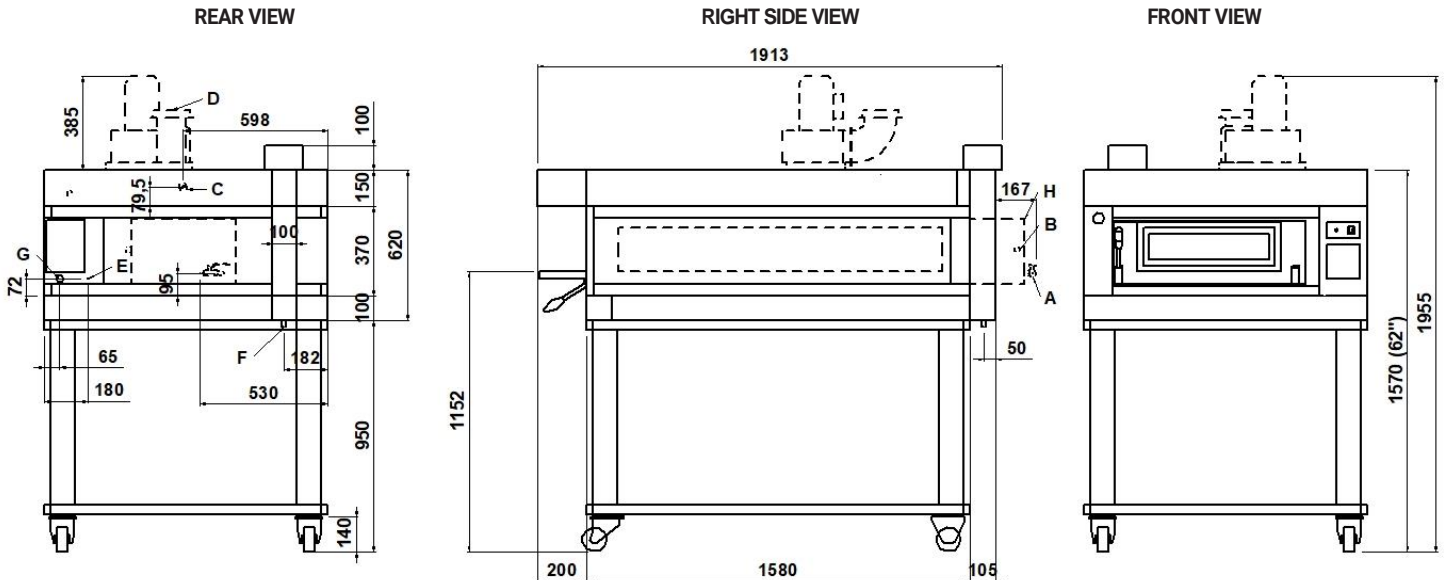

NOTE: The dimensions indicated in the views are in millimeters.

A Ø8 steamer water outlet	B 3/4" male steamer water inlet	C Ø16 hood condensate exhaust	D Ø150 steam exhaust
E M6 equipotential screws	F Ø12 condensate exhaust	G fairleads	H Steamer 1600W (see data sheet)

DIMENSIONS

External height	620mm
External depth	1941mm
External width	1170mm
Weight	211kg

SHIPPING INFORMATION

Packed in wooden crate	
Height	870mm
Depth	2141mm
Width	1370mm
Weight	(211+50)kg

FEEDING AND POWER

Standard feeding	
A.C. V400 3N	
Feeding on request	
A.C. V230 3	
Frequency	50/60Hz
Max power	11kW
*Average power cons	5,5kWh
Connecting cable for each chamber	
type H07RN-F	
5x4mm ² (V400 3N)	
4x6mm ² (V230 3)	
Power supply (optional prover)	
A.C. V230 1N 50/60 Hz	
Max power	1,5kW
*Average power cons	0,8kWh
Conn. Cable type H07RN-F	3x1,5mm ²

TOTAL BAKING CAPACITY

Tray (600x400)mm	4	When combined with leavening
Pizza diameter 300mm	9	compartment or stand:
Pizza diameter 450mm	3	Max height
		Max weight

* This value is subject to variation according to the way in which the equipment is used

NOTE: MORETTI FORNI S.P.A. reserves the right to modify the characteristics of the products illustrated in this publication without prior notice

2 baking chambers height 18cm

(assembled with prover height 800mm)

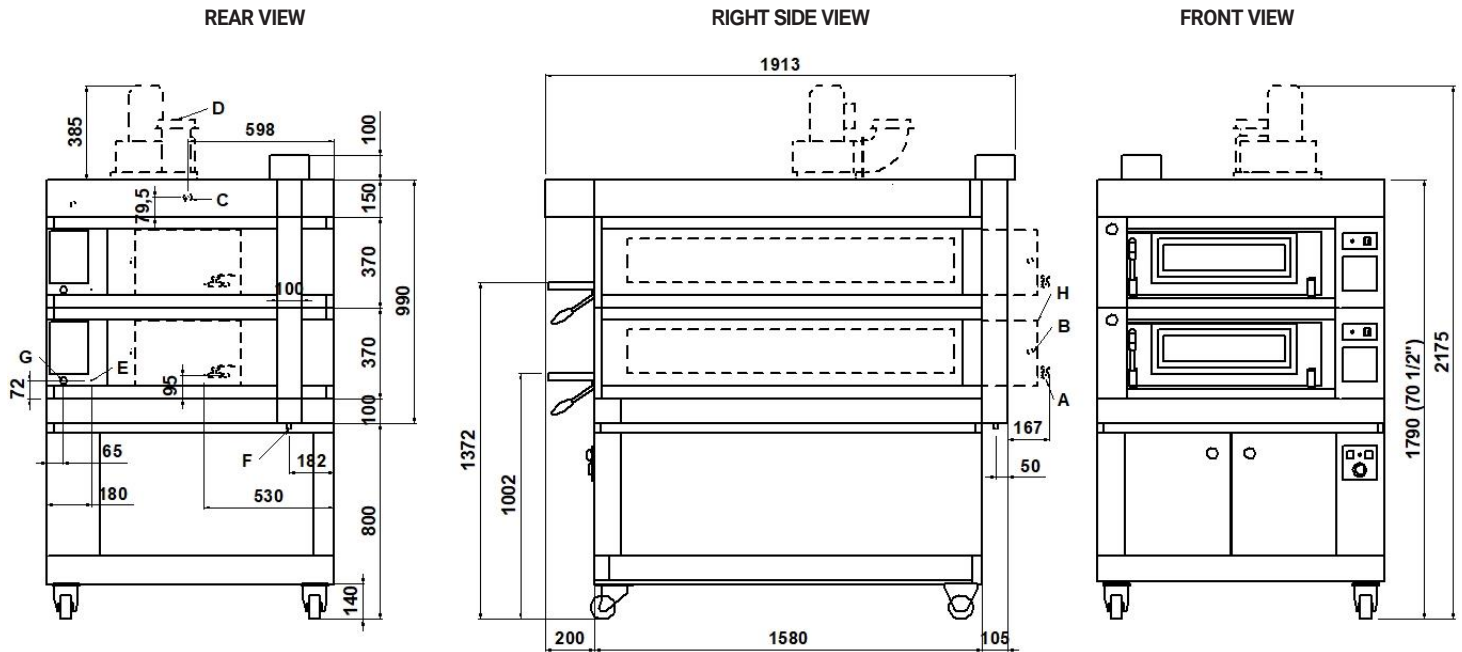

NOTE: The dimensions indicated in the views are in millimeters.

A Ø8 steamer water outlet	B 3/4" male steamer water inlet	C Ø16 Hood condensate exhaust	D Ø150 steam exhaust
E M6 equipotential screws	F Ø12 condensate exhaust	G fairleads	H Steamer 1600W (see data sheet)

DIMENSIONS

External height	990mm
External depth	1941mm
External width	1170mm
Weight	347kg

SHIPPING INFORMATION

Packed in wooden crate	
Height	1240mm
Depth	2141mm
Width	1370mm
Weight	(347+60)kg

FEEDING AND POWER

Standard feeding	
A.C. V400 3N	
Feeding on request	
A.C. V230 3	
Frequency	50/60Hz
Max power	22kW
*Average power cons	11kW
Connecting cable for each chamber	
type H07RN-F	
5x4mm ² (V400 3N)	
4x6mm ² (V230 3)	
Power supply (optional prover)	
A.C. V230 1N 50/60 Hz	
Max power	1,5kW
*Average power cons	0,8kWh
Conn. Cable type H07RN-F	3x1,5mm ²

TOTAL BAKING CAPACITY

Tray (600x400)mm	8	When combined with leavening
Pizza diameter 300mm	18	compartment or stand:
Pizza diameter 450mm	6	Max height
		Max weight

* This value is subject to variation according to the way in which the equipment is used

NOTE: MORETTI FORNI S.P.A. reserves the right to modify the characteristics of the products illustrated in this publication without prior notice

3 baking chambers height 18cm
(assembled with prover height 600mm)

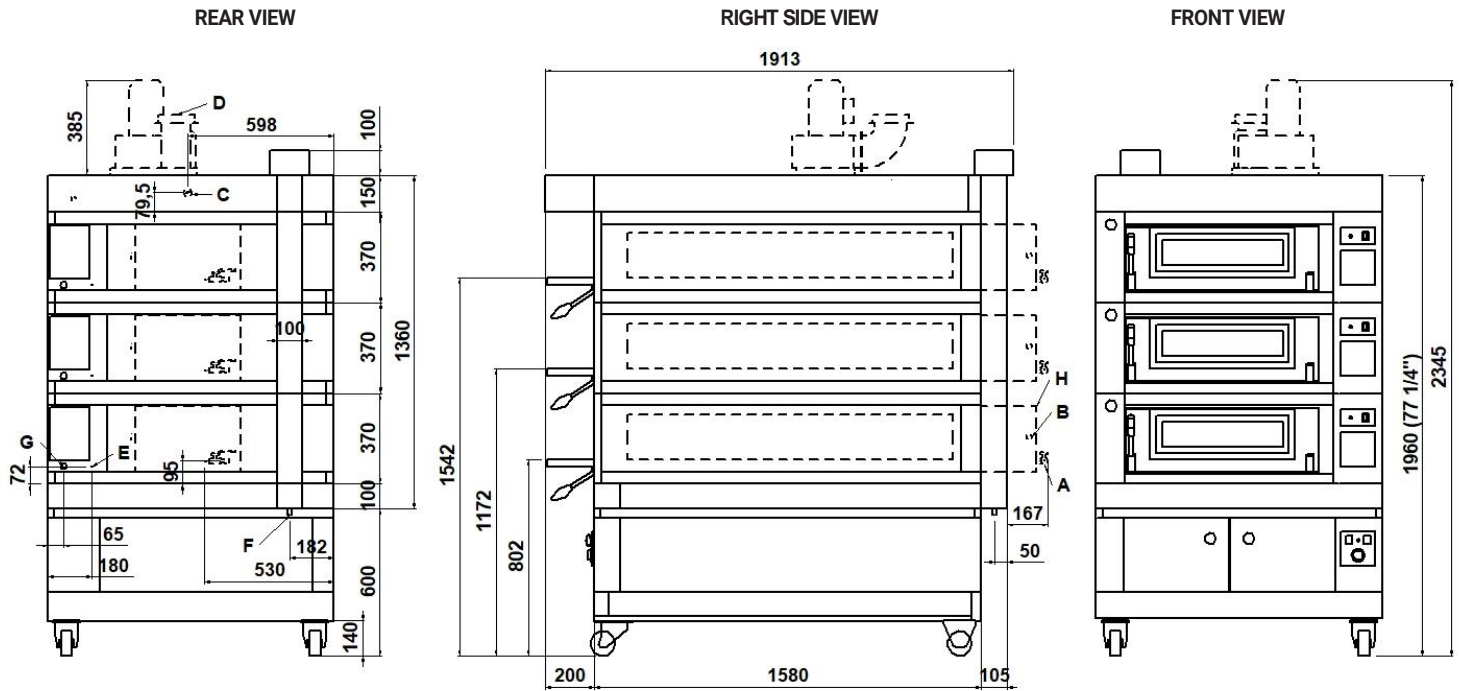

NOTE: The dimensions indicated in the views are in millimeters.

A Ø8 steamer water outlet	B 3/4" male steamer water inlet	C Ø16 Hood condensate exhaust	D Ø150 steam exhaust
E M6 equipotential screws	F Ø12 condensate exhaust	G fairleads	H Steamer 1600W (see data sheet)

DIMENSIONS

External height	1360mm
External depth	1941mm
External width	1170mm
Weight	483kg

SHIPPING INFORMATION

Packed in wooden crate	
Height	1610mm
Depth	2141mm
Width	1370mm
Weight	(483+70)kg

FEEDING AND POWER

Standard feeding	
A.C. V400 3N	
Feeding on request	
A.C. V230 3	
Frequency	50/60Hz
Max power	33kW
*Average power cons	16,5kWh
Connecting cable for each chamber	
type H07RN-F	
5x4mm ² (V400 3N)	
4x6mm ² (V230 3)	
Power supply (optional prover)	
A.C. V230 1N 50/60 Hz	
Max power	1,5kW
*Average power cons	0,8kWh
Conn. Cable type H07RN-F 3x1,5mm ²	

TOTAL BAKING CAPACITY

Tray (600x400)mm	12	When combined with leavening compartment or stand:
Pizza diameter 300mm	27	Max height
Pizza diameter 450mm	9	Max weight

* This value is subject to variation according to the way in which the equipment is used

NOTE: MORETTI FORNI S.P.A. reserves the right to modify the characteristics of the products illustrated in this publication without prior notice

2 baking chambers height 18+30 cm
(assembled with prover height 800mm)

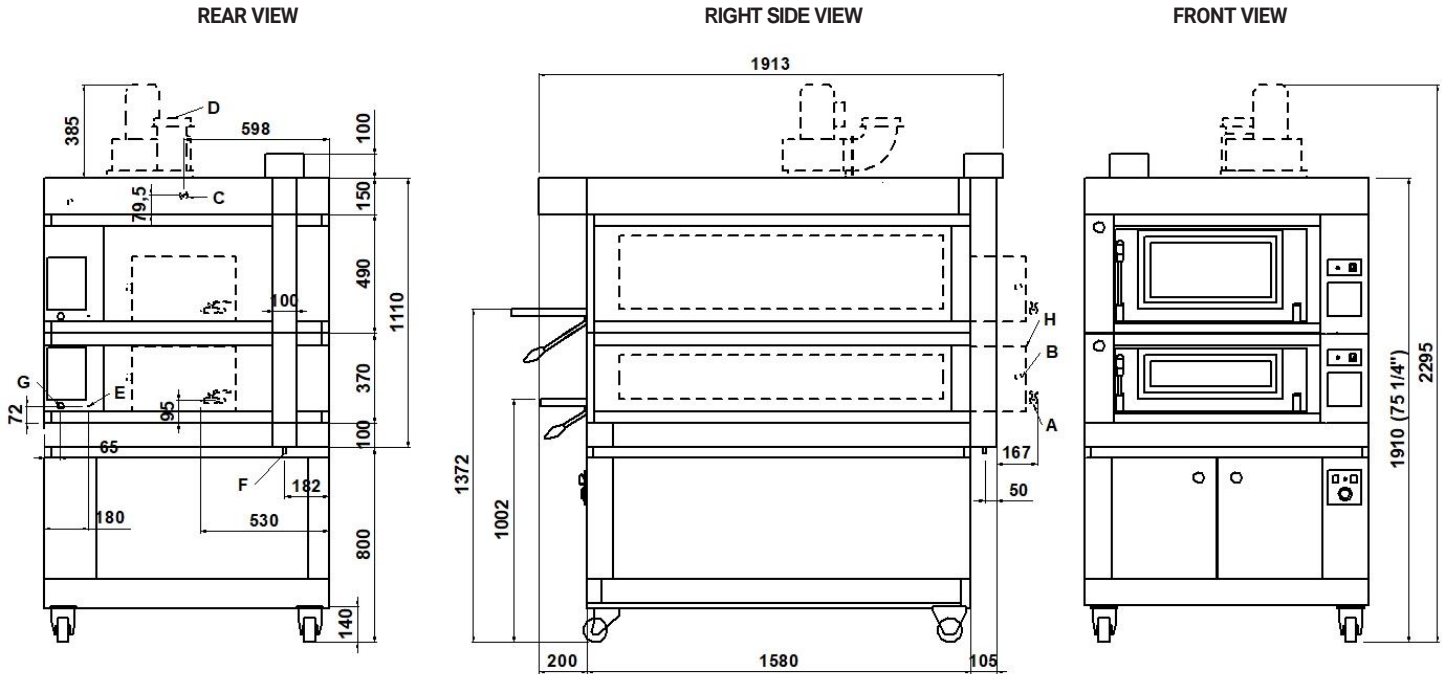

NOTE: The dimensions indicated in the views are in millimeters.

A Ø8 steamer water outlet	B 3/4" male steamer water inlet	C Ø16 Hood condensate exhaust	D Ø150 steam exhaust
E M6 equipotential screws	F Ø12 condensate exhaust	G fairleads	H Steamer 1600W (see data sheet)

DIMENSIONS

External height	1110mm
External depth	1941mm
External width	1170mm
Weight	370kg

TOTAL BAKING CAPACITY

Tray (600x400)mm	8
Pizza diameter 300mm	18
Pizza diameter 450mm	6

SHIPPING INFORMATION

Packed in wooden crate	
Height	1360mm
Depth	2141mm
Width	1370mm
Weight	(370+60)kg

When combined with leavening compartment or stand:	
Max height	2320mm
Max weight	(470+70)kg

FEEDING AND POWER

Standard feeding	
A.C. V400 3N	
Feeding on request	
A.C. V230 3	
Frequency	50/60Hz
Max power	22kW
*Average power cons	22kWh
Connecting cable for each chamber	
type H07RN-F	
5x4mm ² (V400 3N)	
4x6mm ² (V230 3)	
Power supply (optional prover)	
A.C. V230 1N 50/60 Hz	
Max power	1,5kW
*Average power cons	0,8kWh
Conn. Cable type H07RN-F 3x1,5mm ²	

* This value is subject to variation according to the way in which the equipment is used
NOTE: MORETTI FORNI S.P.A. reserves the right to modify the characteristics of the products illustrated in this publication without prior notice

3 baking chambers height 18+18+30 cm
(assembled with stand prover 600mm)

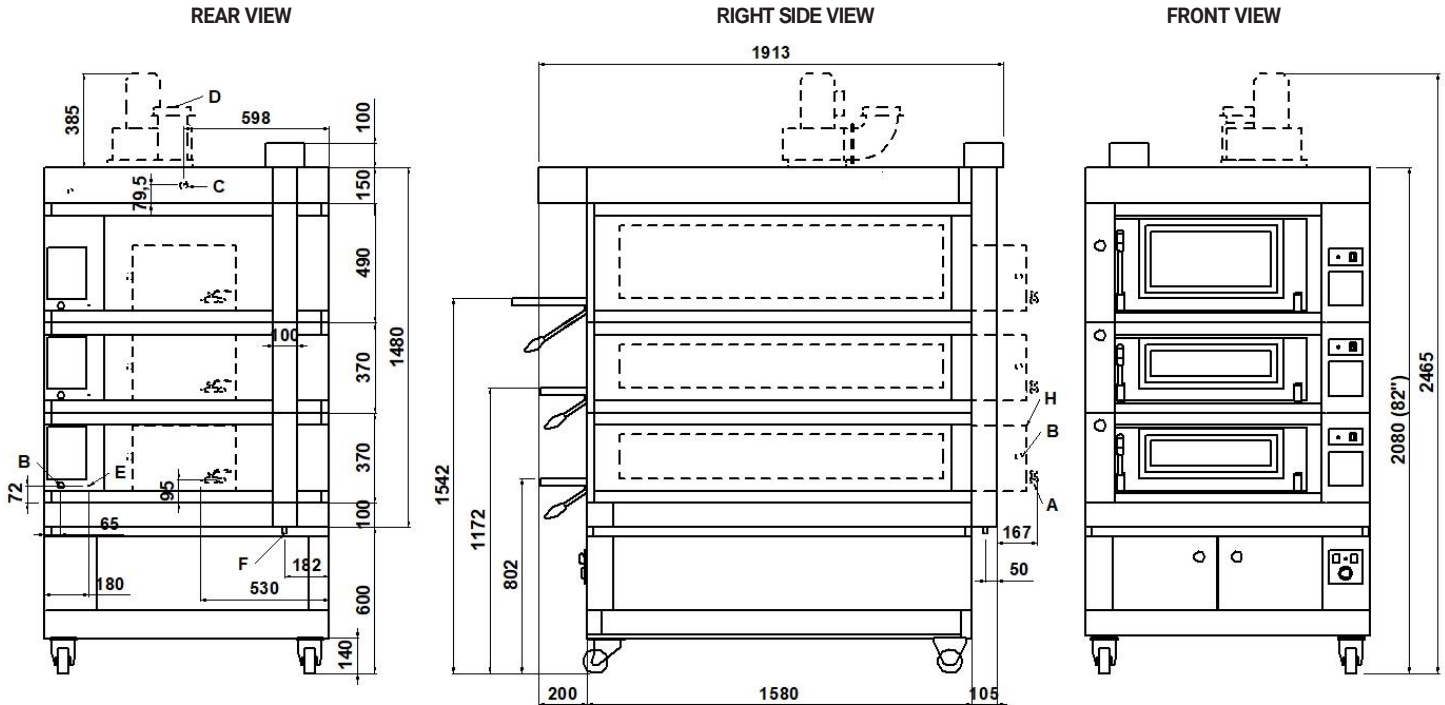

NOTE: The dimensions indicated in the views are in millimeters.

A Ø8 steamer water outlet	B 3/4" male steamer water inlet	C Ø16 Hood condensate exhaust	D Ø150 steam exhaust
E M6 equipotential screws	F Ø12 condensate exhaust	G fairleads	H Steamer 1600W (see data sheet)

DIMENSIONS

External height	1480mm
External depth	1941mm
External width	1170mm
Weight	505kg

SHIPPING INFORMATION

Packed in wooden crate	
Height	1730mm
Depth	2141mm
Width	1370mm
Weight	(505+70)kg

FEEDING AND POWER

Standard feeding	
A.C. V400 3N	
Feeding on request	
A.C. V230 3	
Frequency	50/60Hz
Max power	33kW
*Average power cons	16,5kWh
Connecting cable for each chamber	
type H07RN-F	
5x4mm ² (V400 3N)	
4x6mm ² (V230 3)	
Power supply (optional prover)	
A.C. V230 1N 50/60 Hz	
Max power	1,5kW
*Average power cons	0,8kWh
Conn. Cable type H07RN-F 3x1,5mm ²	

TOTAL BAKING CAPACITY

Tray (600x400)mm	12	When combined with leavening compartment or stand:
Pizza diameter 300mm	27	Max height
Pizza diameter 450mm	9	Max weight

* This value is subject to variation according to the way in which the equipment is used

NOTE: MORETTI FORNI S.P.A. reserves the right to modify the characteristics of the products illustrated in this publication without prior notice

P80

TECHNICAL DATA

SHIPPING INFORMATION H18		P80_1_18	P80_2_18	P80_3_18
Packed in wooden crate	Height	870mm	1240mm	1610mm
	Weight	(211+50)kg	(347+60)kg	(483+70)kg
When combined with prover or stand	Max. height	1820mm	2200mm	2560mm
	Max. weight	(305+60)kg	(441+70)kg	(570+80)kg
SHIPPING INFORMATION H30		P80_1_30	P80_2_30	P80_3_30
Packed in wooden crate	Height	990mm	1480mm	1970mm
	Weight	(225+50)kg	(375+60)kg	(525+70)kg
When combined with prover or stand	Max. height	1940mm	2440mm	2920mm
	Max. weight	(319+60)kg	(469+70)kg	(612+80)kg

FEEDING AND POWER (REFERRED TO 1 BAKING CHAMBER)	Max power	Pizzeria	kW	11
	*Average power consumption		kWh	5,5
	Max power	Pastry	kW	8,5
	*Average power consumption		kWh	4,3
	Max power	Boosted heating elements	kW	10,2
	*Average power consumption		kWh	5,1

* This value is subject to variation according to the way in which the equipment is used

NOTE: MORETTI FORNI S.P.A. reserves the right to modify the characteristics of the products illustrated in this publication without prior notice