



Modular conveyor oven

T64G, the gas modular conveyor oven, is composed of one or more **stackable baking chambers** and an optional stand. During baking, the product is placed on the conveyor belt and passes through two flows of hot air: **impingement technology**, the best system for heat distribution in the whole baking chamber for **perfect baking of pizza, pastry, bakery, and gastronomy**. Efficiently insulated and isolated, the external surfaces are cool even during use. Installable as countertop or on an optional stand closed by stainless steel doors on swivel castors. The baking chamber maximum temperature is 320°C (608°F).



OPERATION

- Heating by means of blowing burner with premixing function of air and gas
- Electronically modulated control of burner flame that allows the automatic energy control on the strength of the quantity of the baked product ADAPTIVE-GAS® TECHNOLOGY
- Electronic control of temperature
- Continuous check-up of temperature through thermocouple
- Sistema di soffiaggio aria ottenuto con ventola d'acciaio inox
- Conveyor belt with speed adjustable from 30" to 20 minutes and feed-back control at the option of belt standstill
- Programmable electronic function management ECO-SMARTBAKING®
- Different baking heating regulations between upper and lower part of the product DUAL FLOW® TECHNOLOGY
- Maximum temperature reached 320°C (608°F)
- Independent system for additional forced air cooling of the components with low noise

CONSTRUCTION

- Structure in folded stainless steel sheets
- Stainless steel door hinged on left hand side with logo BlackBar® Design
- Extractable stainless steel conveyor belt, with continuous tensioning
- Electronic control panel on front left side
- Peephole for checking the burner status
- Adjustable feet
- Baking chamber in stainless steel sheets
- Top and bottom blowers in welded stainless steel sheets, extractable for cleaning
- Low-emission (NOx, CO) stainless steel burner
- Combustion chamber entirely built with special high-temperatures stainless steel
- Rock wool heat insulation, thermal minijoints and air space COOL AROUND® Technology

ACCESSORIES

- Stand with castors, height 137, 600mm
- Loading or unloading roller
- Harvest bread basket
- Remote-Master® Technology

BAKING DIMENSIONS

Belt width L	406mm
Internal length	510mm
Total length P	1234mm
Total length P with pizza rest	1484mm
Tot. baking surface	0,2m ²

STANDARD EQUIPMENT

- 4 displays
- 20 customisable programs
- ECO-STAND BY™ TECHNOLOGY Saving device with the possibility to stop the belt for break
- Discontinuous baking cycle STEP
- Double pass baking cycle RETURN
- LOCK function
- Auto test with display of error message
- Independent maximum temperature safety device
- Stainless steel resting support (+250mm)
- SmartBaking app
- Wifi module for sw update

TOP VIEW

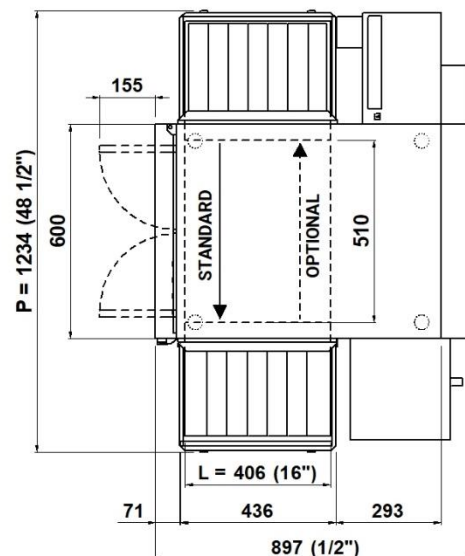

1 baking chamber

(assembled with stand height 600mm)

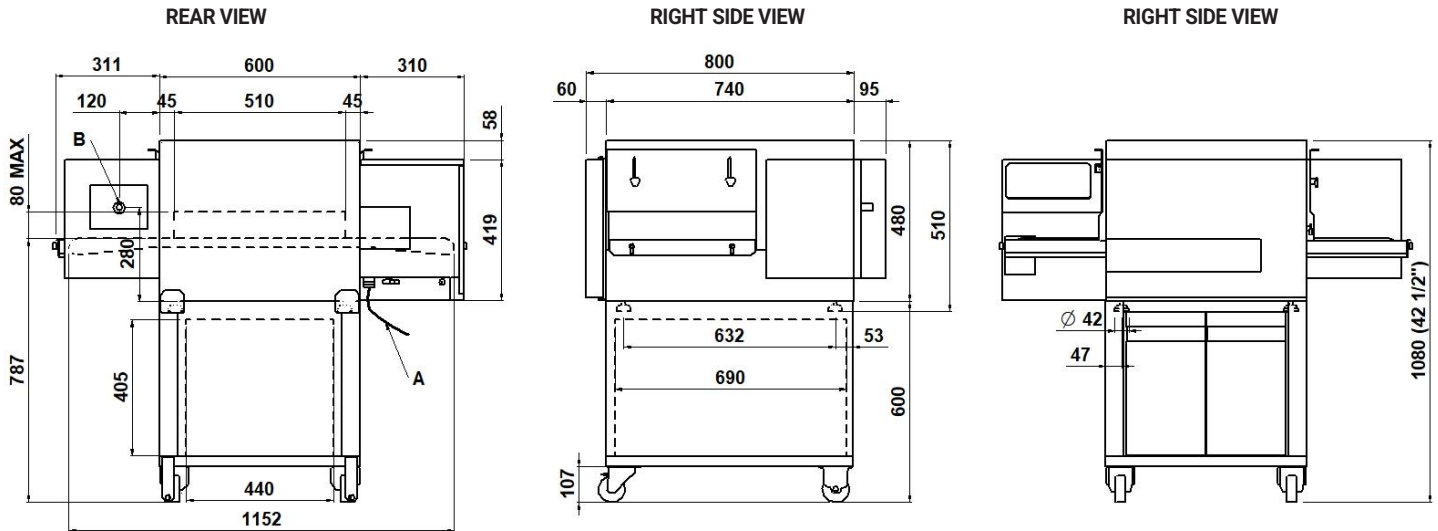

NOTE: The dimensions indicated in the views are in millimeters.

A Electrical cable length 4 meters	B Cone-shaped male gas manifold 1/2" GAS		
---	---	--	--

DIMENSIONS

External height	1080mm
External depth.	897mm
External width.	1234mm
Weight (excl. stand)	111kg

TOTAL BAKING CAPACITY

*N° Pizzas /hour	N°25
Pizzas diameter 330mm	

SHIPPING INFORMATION

Dimensions of packed oven	
Height	655mm
Depth	1040mm
Width	1380mm
Weight	(120+15)kg

Packaged stand dimensions:

Height	600mm
Depth	650mm
Width	790mm
Weight	(18+5)kg

FEEDING AND POWER

Type of equipment	A3-B23
Thermic power max	9,9kW
Therm. power reduced	3kW
Gas power: NATURAL GAS or LPG	
*Hour consumption max	
Natural gas G20	1,05m³/h
Natural gas G25	1,22m³/h
Natural gas G25.1	1,22m³/h
Natural gas G25.3	1,191m³/h
LPG G30	0,78kg/h
LPG G31	0,77kg/h
Standard electric power	
A.C. V230 1N	
Frequency	50/60Hz
Electric power	0,4kW
Connecting cable for each chamber type:	
H07RN-F	3x1,5mm²

* This value is subject to variation according to the way in which the equipment is used

NOTE: MORETTI FORNI S.P.A. reserves the right to modify the characteristics of the products illustrated in this publication without prior notice

2 baking chambers
(assembled with stand height 600mm)

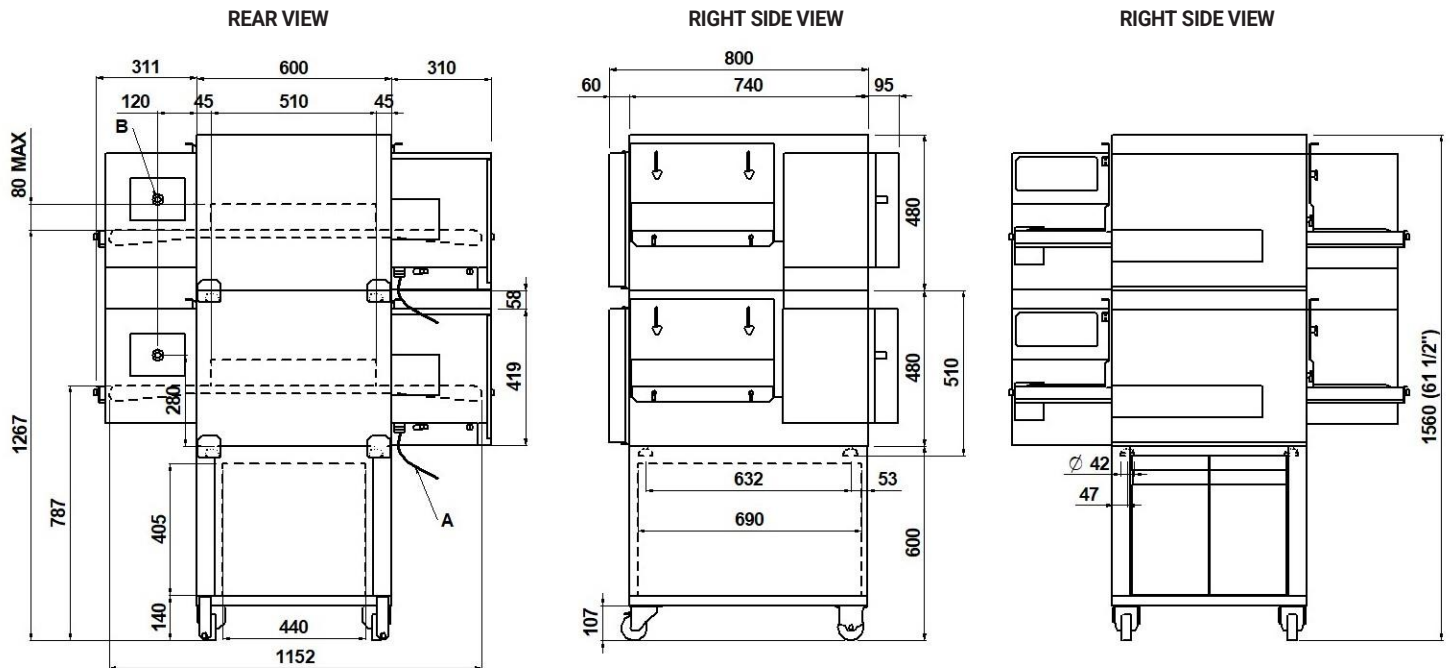

NOTE: The dimensions indicated in the views are in millimeters.

A Electrical cable length 4 meters	B Cone-shaped male gas manifold 1/2" GAS		
---	---	--	--

DIMENSIONS

External height	1560mm
External depth.	897mm
External width.	1234mm
Weight (excl. stand)	222kg

TOTAL BAKING CAPACITY

*N° Pizzas /hour	N°50
Pizzas diameter 330mm	

SHIPPING INFORMATION

Packed oven (each packed deck)	
Height	2x655mm
Depth	1040mm
Width	1380mm
Weight	(240+30)kg

Packaged stand dimensions:

Height	600mm
Depth	650mm
Width	790mm
Weight	(18+5)kg

FEEDING AND POWER

Type of equipment	A3-B23
Thermic power max	19,8kW
Therm. power reduced	6kW
Gas power: NATURAL GAS or LPG	
*Hour consumption max	
Natural gas G20	2,1m ³ /h
Natural gas G25	2,44m ³ /h
Natural gas G25.1	2,44m ³ /h
Natural gas G25.3	2,382m ³ /h
LPG G30	1,56kg/h
LPG G31	1,54kg/h
Standard electric power	
A.C. V230 1N	
Frequency	50/60Hz
Electric power	0,8kW
Connecting cable for each chamber type:	
H07RN-F	3x1,5mm ²

* This value is subject to variation according to the way in which the equipment is used

NOTE: MORETTI FORNI S.P.A. reserves the right to modify the characteristics of the products illustrated in this publication without prior notice

3 baking chambers
(assembled with stand height 137mm)

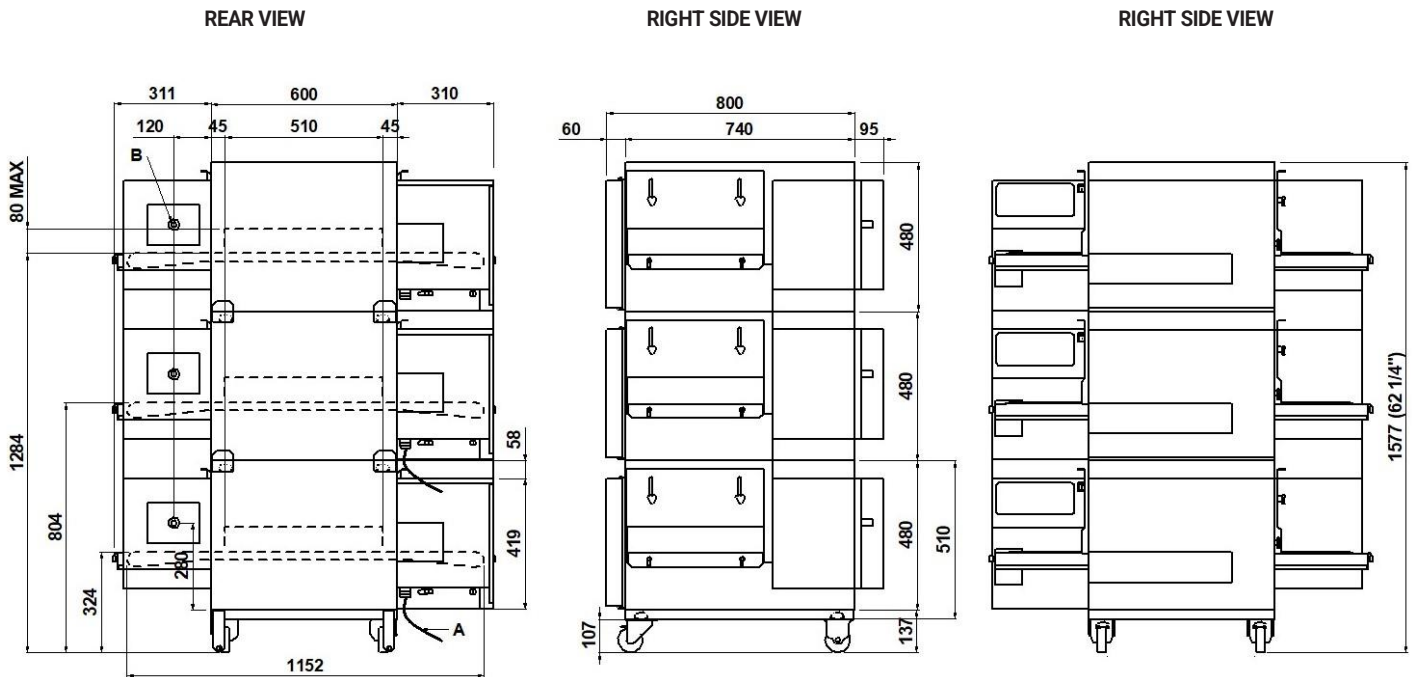

NOTE: The dimensions indicated in the views are in millimeters.

A Electrical cable length 4 meters	B Cone-shaped male gas manifold 1/2" GAS		
---	---	--	--

DIMENSIONS

External height	1577mm
External depth.	897mm
External width.	1234mm
Weight (excl. stand)	333kg

TOTAL BAKING CAPACITY

*N° Pizzas /hour	N°75
Pizzas diameter 330mm	

SHIPPING INFORMATION

Packed oven (each packed deck)	3x655mm
Height	1040mm
Depth	1380mm
Width	(360+45)kg
Weight	

Packaged stand dimensions:	
Height	200mm
Depth	630mm
Width	800mm
Weight	(15+3)kg

FEEDING AND POWER

Type of equipment	A3-B23
Thermic power max	29,7kW
Therm. power reduced	9kW
Gas power: NATURAL GAS or LPG	
*Hour consumption max	
Natural gas G20	3,15m ³ /h
Natural gas G25	3,66m ³ /h
Natural gas G25.1	3,66m ³ /h
Natural gas G25.3	3,573m ³ /h
LPG G30	2,34kg/h
LPG G31	2,31kg/h
Standard electric power	
A.C. V230 1N	
Frequency	50/60Hz
Electric power	1,2kW
Connecting cable for each chamber type:	
H07RN-F	3x1,5mm ²

* This value is subject to variation according to the way in which the equipment is used

NOTE: MORETTI FORNI S.P.A. reserves the right to modify the characteristics of the products illustrated in this publication without prior notice



Modular conveyor oven

T64G, the gas modular conveyor oven, is composed of one or more **stackable baking chambers** and an optional stand. During baking, the product is placed on the conveyor belt and passes through two flows of hot air: **impingement technology**, the best system for heat distribution in the whole baking chamber for **perfect baking of pizza, pastry, bakery, and gastronomy**. Efficiently insulated and isolated, the external surfaces are cool even during use. Installable as countertop or on an optional stand closed by stainless steel doors on swivel castors. The baking chamber maximum temperature is 320°C (608°F).



OPERATION

- Heating by means of blowing burner with premixing function of air and gas
- Electronically modulated control of burner flame that allows the automatic energy control on the strength of the quantity of the baked product ADAPTIVE-GAS® TECHNOLOGY
- Electronic control of temperature
- Continuous check-up of temperature through thermocouple
- Sistema di soffiaggio aria ottenuto con ventola d'acciaio inox
- Conveyor belt with speed adjustable from 30" to 20 minutes and feed-back control at the option of belt standstill
- Programmable electronic function management ECO-SMARTBAKING®
- Different baking heating regulations between upper and lower part of the product DUAL FLOW® TECHNOLOGY
- Maximum temperature reached 320°C (608°F)
- Independent system for additional forced air cooling of the components with low noise

CONSTRUCTION

- Structure in folded stainless steel sheets
- Stainless steel door hinged on left hand side with logo BlackBar® Design
- Extractable stainless steel conveyor belt, with continuous tensioning
- Electronic control panel on front left side
- Peephole for checking the burner status
- Adjustable feet
- Baking chamber in stainless steel sheets
- Top and bottom blowers in welded stainless steel sheets, extractable for cleaning
- Low-emission (NOx, CO) stainless steel burner
- Combustion chamber entirely built with special high-temperatures stainless steel
- Rock wool heat insulation, thermal minijoints and air space COOL AROUND® Technology

ACCESSORIES

- Stand with castors, height 137, 600mm
- Loading or unloading roller
- Harvest bread basket
- Remote-Master® Technology

BAKING DIMENSIONS

Belt width L	406mm
Internal length	510mm
Total length P	1234mm
Total length P with pizza rest	1484mm
Tot. baking surface	0,2m ²

STANDARD EQUIPMENT

- 4 displays
- 20 customisable programs
- ECO-STAND BY™ TECHNOLOGY Saving device with the possibility to stop the belt for break
- Discontinuous baking cycle STEP
- Double pass baking cycle RETURN
- LOCK function
- Auto test with display of error message
- Independent maximum temperature safety device
- Stainless steel resting support (+250mm)
- SmartBaking app
- Wifi module for sw update

TOP VIEW

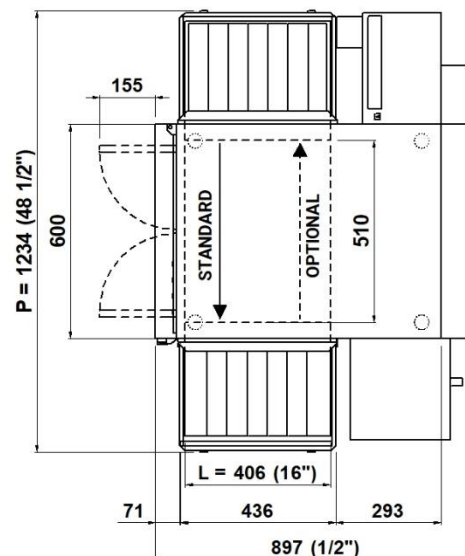

1 baking chamber

(assembled with stand height 600mm)

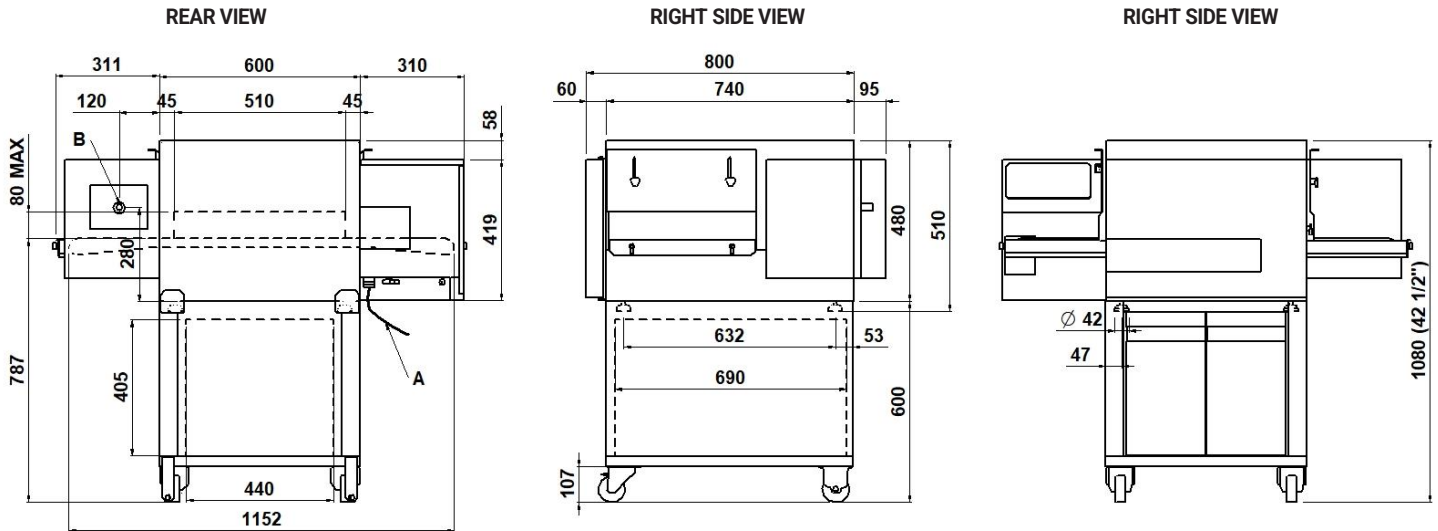

NOTE: The dimensions indicated in the views are in millimeters.

A Electrical cable length 4 meters	B Cone-shaped male gas manifold 1/2" GAS		
---	---	--	--

DIMENSIONS

External height	1080mm
External depth.	897mm
External width.	1234mm
Weight (excl. stand)	111kg

TOTAL BAKING CAPACITY

*N° Pizzas /hour	N°25
Pizzas diameter 330mm	

SHIPPING INFORMATION

Dimensions of packed oven	
Height	655mm
Depth	1040mm
Width	1380mm
Weight	(120+15)kg

Packaged stand dimensions:

Height	600mm
Depth	650mm
Width	790mm
Weight	(18+5)kg

FEEDING AND POWER

Type of equipment	A3-B23
Thermic power max	9,9kW
Therm. power reduced	3kW
Gas power: NATURAL GAS or LPG	
*Hour consumption max	
Natural gas G20	1,05m ³ /h
Natural gas G25	1,22m ³ /h
Natural gas G25.1	1,22m ³ /h
Natural gas G25.3	1,191m ³ /h
LPG G30	0,78kg/h
LPG G31	0,77kg/h
Standard electric power	
A.C. V230 1N	
Frequency	50/60Hz
Electric power	0,4kW
Connecting cable for each chamber type:	
H07RN-F	3x1,5mm ²

* This value is subject to variation according to the way in which the equipment is used

NOTE: MORETTI FORNI S.P.A. reserves the right to modify the characteristics of the products illustrated in this publication without prior notice

2 baking chambers
(assembled with stand height 600mm)

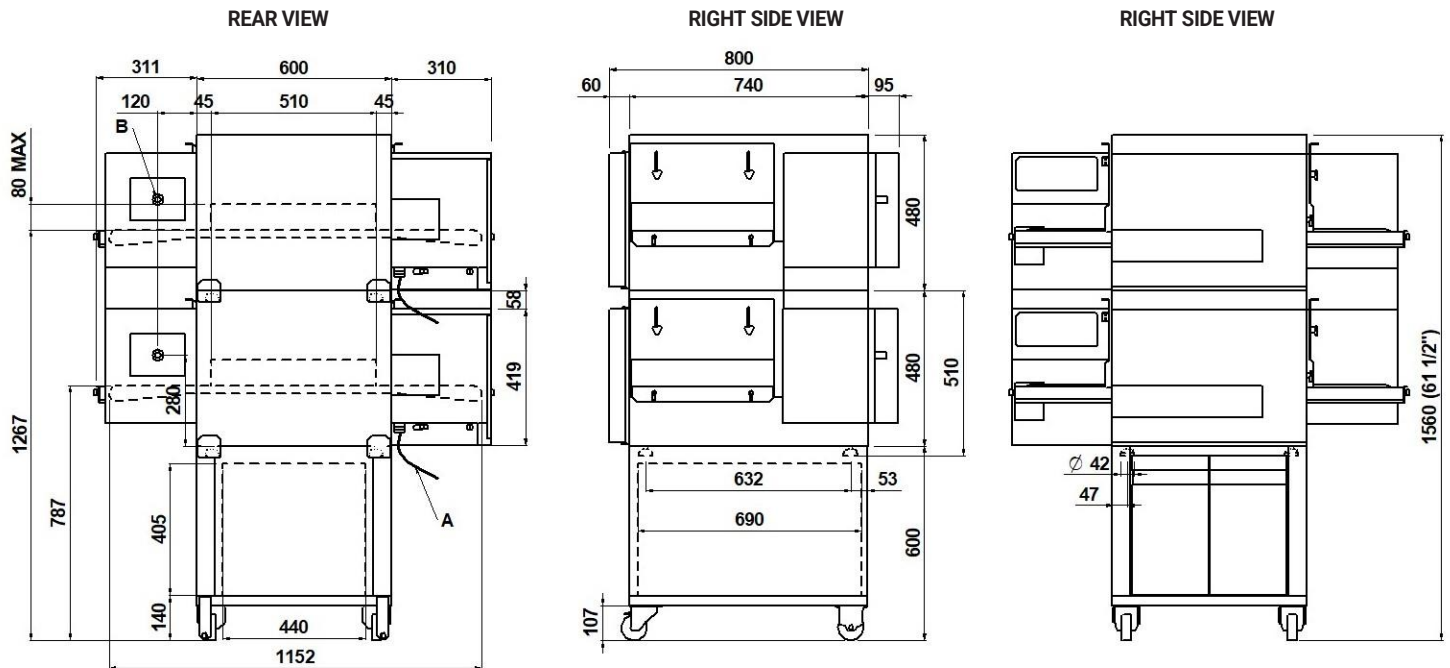

NOTE: The dimensions indicated in the views are in millimeters.

A Electrical cable length 4 meters	B Cone-shaped male gas manifold 1/2" GAS		
---	---	--	--

DIMENSIONS

External height	1560mm
External depth.	897mm
External width.	1234mm
Weight (excl. stand)	222kg

TOTAL BAKING CAPACITY

*N° Pizzas /hour	N°50
Pizzas diameter 330mm	

SHIPPING INFORMATION

Packed oven (each packed deck)	
Height	2x655mm
Depth	1040mm
Width	1380mm
Weight	(240+30)kg

Packaged stand dimensions:

Height	600mm
Depth	650mm
Width	790mm
Weight	(18+5)kg

FEEDING AND POWER

Type of equipment	A3-B23
Thermic power max	19,8kW
Therm. power reduced	6kW
Gas power: NATURAL GAS or LPG	
*Hour consumption max	
Natural gas G20	2,1m ³ /h
Natural gas G25	2,44m ³ /h
Natural gas G25.1	2,44m ³ /h
Natural gas G25.3	2,382m ³ /h
LPG G30	1,56kg/h
LPG G31	1,54kg/h
Standard electric power	
A.C. V230 1N	
Frequency	50/60Hz
Electric power	0,8kW
Connecting cable for each chamber type:	
H07RN-F	3x1,5mm ²

* This value is subject to variation according to the way in which the equipment is used

NOTE: MORETTI FORNI S.P.A. reserves the right to modify the characteristics of the products illustrated in this publication without prior notice

3 baking chambers
(assembled with stand height 137mm)

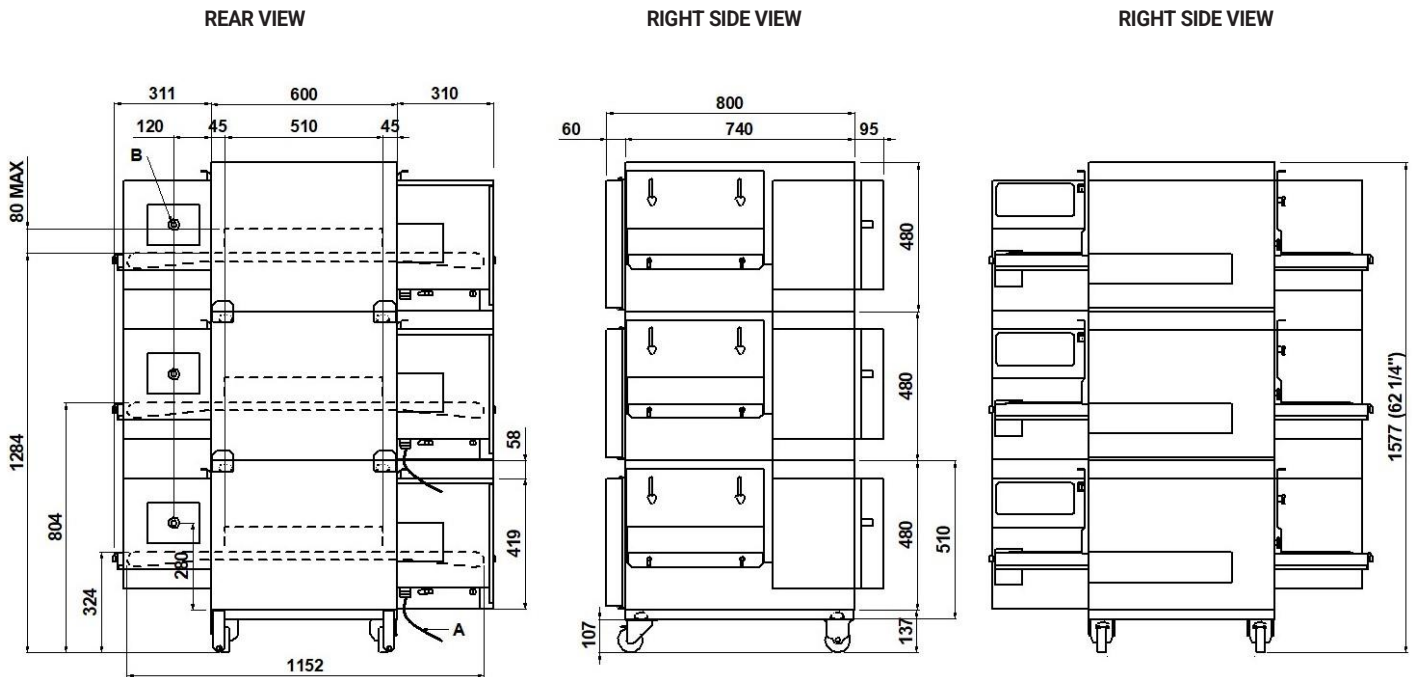

NOTE: The dimensions indicated in the views are in millimeters.

A Electrical cable length 4 meters	B Cone-shaped male gas manifold 1/2" GAS		
---	---	--	--

DIMENSIONS

External height	1577mm
External depth.	897mm
External width.	1234mm
Weight (excl. stand)	333kg

TOTAL BAKING CAPACITY

*N° Pizzas /hour	N°75
Pizzas diameter 330mm	

SHIPPING INFORMATION

Packed oven (each packed deck)	3x655mm
Height	1040mm
Depth	1380mm
Width	(360+45)kg
Weight	

Packaged stand dimensions:

Height	200mm
Depth	630mm
Width	800mm
Weight	(15+3)kg

FEEDING AND POWER

Type of equipment	A3-B23
Thermic power max	29,7kW
Therm. power reduced	9kW
Gas power: NATURAL GAS or LPG	
*Hour consumption max	
Natural gas G20	3,15m ³ /h
Natural gas G25	3,66m ³ /h
Natural gas G25.1	3,66m ³ /h
Natural gas G25.3	3,573m ³ /h
LPG G30	2,34kg/h
LPG G31	2,31kg/h
Standard electric power	
A.C. V230 1N	
Frequency	50/60Hz
Electric power	1,2kW
Connecting cable for each chamber type:	
H07RN-F	3x1,5mm ²

* This value is subject to variation according to the way in which the equipment is used

NOTE: MORETTI FORNI S.P.A. reserves the right to modify the characteristics of the products illustrated in this publication without prior notice



Modular conveyor oven

T64G, the gas modular conveyor oven, is composed of one or more **stackable baking chambers** and an optional stand. During baking, the product is placed on the conveyor belt and passes through two flows of hot air: **impingement technology**, the best system for heat distribution in the whole baking chamber for **perfect baking of pizza, pastry, bakery, and gastronomy**. Efficiently insulated and isolated, the external surfaces are cool even during use. Installable as countertop or on an optional stand closed by stainless steel doors on swivel castors. The baking chamber maximum temperature is 320°C (608°F).



OPERATION

- Heating by means of blowing burner with premixing function of air and gas
- Electronically modulated control of burner flame that allows the automatic energy control on the strength of the quantity of the baked product ADAPTIVE-GAS® TECHNOLOGY
- Electronic control of temperature
- Continuous check-up of temperature through thermocouple
- Sistema di soffiaggio aria ottenuto con ventola d'acciaio inox
- Conveyor belt with speed adjustable from 30" to 20 minutes and feed-back control at the option of belt standstill
- Programmable electronic function management ECO-SMARTBAKING®
- Different baking heating regulations between upper and lower part of the product DUAL FLOW® TECHNOLOGY
- Maximum temperature reached 320°C (608°F)
- Independent system for additional forced air cooling of the components with low noise

CONSTRUCTION

- Structure in folded stainless steel sheets
- Stainless steel door hinged on left hand side with logo BlackBar® Design
- Extractable stainless steel conveyor belt, with continuous tensioning
- Electronic control panel on front left side
- Peephole for checking the burner status
- Adjustable feet
- Baking chamber in stainless steel sheets
- Top and bottom blowers in welded stainless steel sheets, extractable for cleaning
- Low-emission (NOx, CO) stainless steel burner
- Combustion chamber entirely built with special high-temperatures stainless steel
- Rock wool heat insulation, thermal minijoints and air space COOL AROUND® Technology

ACCESSORIES

- Stand with castors, height 137, 600mm
- Loading or unloading roller
- Harvest bread basket
- Remote-Master® Technology

BAKING DIMENSIONS

Belt width L	406mm
Internal length	510mm
Total length P	1234mm
Total length P with pizza rest	1484mm
Tot. baking surface	0,2m ²

STANDARD EQUIPMENT

- 4 displays
- 20 customisable programs
- ECO-STAND BY™ TECHNOLOGY Saving device with the possibility to stop the belt for break
- Discontinuous baking cycle STEP
- Double pass baking cycle RETURN
- LOCK function
- Auto test with display of error message
- Independent maximum temperature safety device
- Stainless steel resting support (+250mm)
- SmartBaking app
- Wifi module for sw update

TOP VIEW

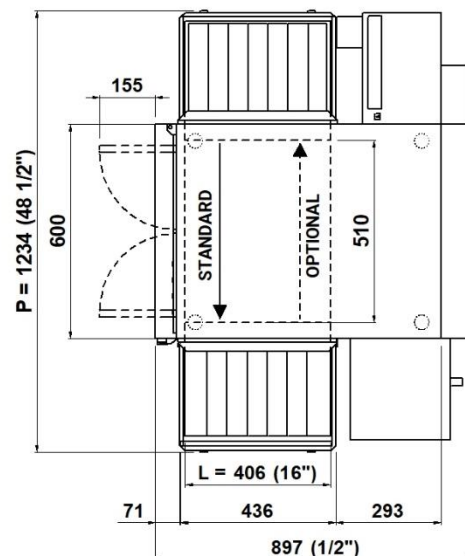

1 baking chamber

(assembled with stand height 600mm)

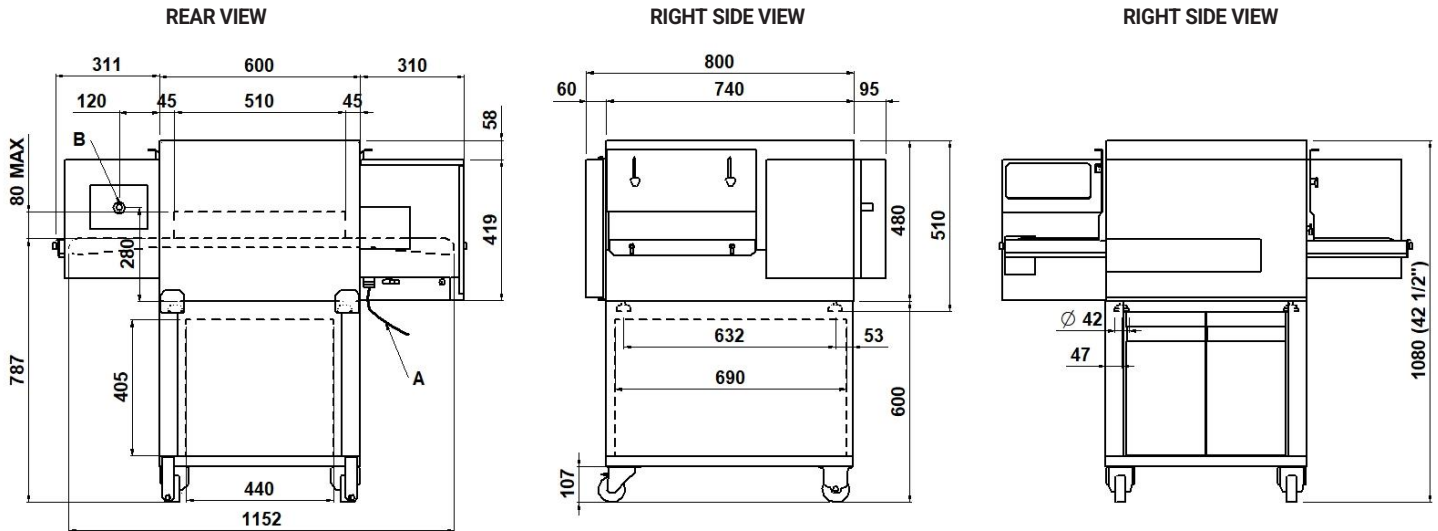

NOTE: The dimensions indicated in the views are in millimeters.

A Electrical cable length 4 meters	B Cone-shaped male gas manifold 1/2" GAS		
---	---	--	--

DIMENSIONS

External height	1080mm
External depth.	897mm
External width.	1234mm
Weight (excl. stand)	111kg

TOTAL BAKING CAPACITY

*N° Pizzas /hour	N°25
Pizzas diameter 330mm	

SHIPPING INFORMATION

Dimensions of packed oven	
Height	655mm
Depth	1040mm
Width	1380mm
Weight	(120+15)kg

Packaged stand dimensions:

Height	600mm
Depth	650mm
Width	790mm
Weight	(18+5)kg

FEEDING AND POWER

Type of equipment	A3-B23
Thermic power max	9,9kW
Therm. power reduced	3kW
Gas power: NATURAL GAS or LPG	
*Hour consumption max	
Natural gas G20	1,05m ³ /h
Natural gas G25	1,22m ³ /h
Natural gas G25.1	1,22m ³ /h
Natural gas G25.3	1,191m ³ /h
LPG G30	0,78kg/h
LPG G31	0,77kg/h
Standard electric power	
A.C. V230 1N	
Frequency	50/60Hz
Electric power	0,4kW
Connecting cable for each chamber type:	
H07RN-F	3x1,5mm ²

* This value is subject to variation according to the way in which the equipment is used

NOTE: MORETTI FORNI S.P.A. reserves the right to modify the characteristics of the products illustrated in this publication without prior notice

2 baking chambers
(assembled with stand height 600mm)

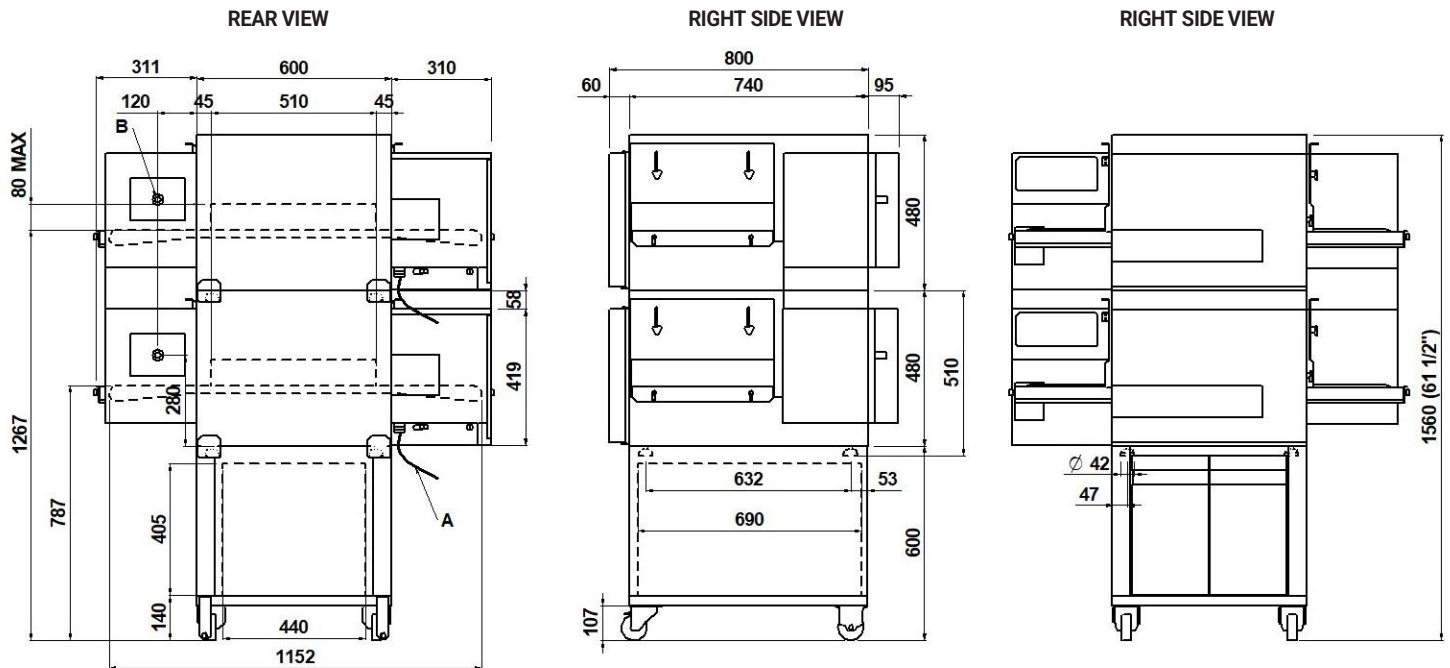

NOTE: The dimensions indicated in the views are in millimeters.

A Electrical cable length 4 meters	B Cone-shaped male gas manifold 1/2" GAS		
---	---	--	--

DIMENSIONS

External height	1560mm
External depth.	897mm
External width.	1234mm
Weight (excl. stand)	222kg

TOTAL BAKING CAPACITY

*N° Pizzas /hour	N°50
Pizzas diameter 330mm	

SHIPPING INFORMATION

Packed oven (each packed deck)	Height 2x655mm
Depth	1040mm
Width	1380mm
Weight	(240+30)kg

Packaged stand dimensions:

Height	600mm
Depth	650mm
Width	790mm
Weight	(18+5)kg

FEEDING AND POWER

Type of equipment	A3-B23
Thermic power max	19,8kW
Therm. power reduced	6kW
Gas power: NATURAL GAS or LPG	
*Hour consumption max	
Natural gas G20	2,1m ³ /h
Natural gas G25	2,44m ³ /h
Natural gas G25.1	2,44m ³ /h
Natural gas G25.3	2,382m ³ /h
LPG G30	1,56kg/h
LPG G31	1,54kg/h
Standard electric power	
A.C. V230 1N	
Frequency	50/60Hz
Electric power	0,8kW
Connecting cable for each chamber type:	
H07RN-F	3x1,5mm ²

* This value is subject to variation according to the way in which the equipment is used

NOTE: MORETTI FORNI S.P.A. reserves the right to modify the characteristics of the products illustrated in this publication without prior notice

3 baking chambers
(assembled with stand height 137mm)

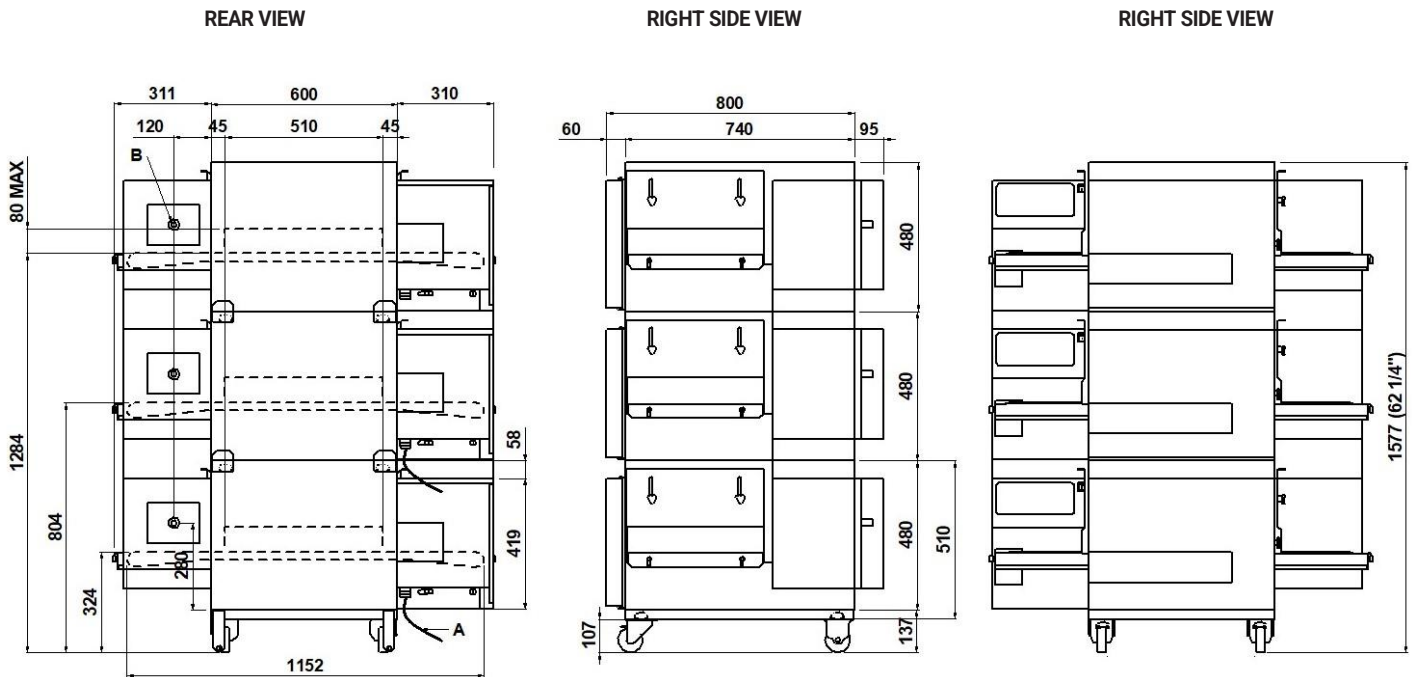

NOTE: The dimensions indicated in the views are in millimeters.

A Electrical cable length 4 meters	B Cone-shaped male gas manifold 1/2" GAS		
--	--	--	--

DIMENSIONS

External height	1577mm
External depth.	897mm
External width.	1234mm
Weight (excl. stand)	333kg

TOTAL BAKING CAPACITY

*N° Pizzas /hour	N°75
Pizzas diameter 330mm	

SHIPPING INFORMATION

Packed oven (each packed deck)	3x655mm
Height	1040mm
Depth	1380mm
Width	(360+45)kg
Weight	

Packaged stand dimensions:

Height	200mm
Depth	630mm
Width	800mm
Weight	(15+3)kg

FEEDING AND POWER

Type of equipment	A3-B23
Thermic power max	29,7kW
Therm. power reduced	9kW
Gas power: NATURAL GAS or LPG	
*Hour consumption max	
Natural gas G20	3,15m ³ /h
Natural gas G25	3,66m ³ /h
Natural gas G25.1	3,66m ³ /h
Natural gas G25.3	3,573m ³ /h
LPG G30	2,34kg/h
LPG G31	2,31kg/h
Standard electric power	
A.C. V230 1N	
Frequency	50/60Hz
Electric power	1,2kW
Connecting cable for each chamber type:	
H07RN-F	3x1,5mm ²

* This value is subject to variation according to the way in which the equipment is used

NOTE: MORETTI FORNI S.P.A. reserves the right to modify the characteristics of the products illustrated in this publication without prior notice