



Modular conveyor oven

T65E, the electric modular conveyor oven, is composed of one or more **stackable baking chambers** and an optional stand. During baking, the product is placed on the conveyor belt and passes through two flows of hot air: **impingement technology**, the best system for heat distribution in the whole baking chamber for **perfect baking of pizza, pastry, bakery, and gastronomy**. Management of needed power is automatic according to the load. The power control of ceiling and floor is independent and managed by two probes. The conveyor speed is adjustable. Efficiently insulated and isolated, the external surfaces are cool even during use. Installable as countertop or on an optional stand closed by stainless steel doors on swivel castors. The baking chamber maximum temperature is 320°C (608°F).



OPERATION

- Heated by armoured heating elements
- Control of power PID (Proportional Supplementary Derivative) can allow the automatic regulation of energy necessary on the basis of the quantity of the batch product **ADAPTIVE-POWER® TECHNOLOGY**
- Independent adjustment and control of ceiling and floor, with continuous temperature detection using 2 high sensitive thermocouples **DUAL-TEMP® TECHNOLOGY**
- Air blowing system using stainless steel fan
- Conveyor belt with speed adjustable from 30" to 20 minutes and feed-back control at the option of belt standstill
- Programmable electronic function management **ECO-SMARTBAKING®**
- Maximum temperature reached 320°C (608°F)
- Independent system for additional forced air cooling of the components with low noise

CONSTRUCTION

- Structure in folded stainless steel sheets
- Stainless steel door hinged on left hand side with logo **BlackBar® Design**
- Extractable stainless steel conveyor belt, with continuous tensioning
- Electronic control panel on front left side
- Adjustable feet
- Baking chamber in stainless steel sheets
- Top and bottom blowers in welded stainless steel sheets, extractable for cleaning
- Rock wool heat insulation, thermal minijoints and air space **COOL AROUND® Technology**

ACCESSORIES

- Stand with castors, height 137, 600mm
- Loading or unloading roller
- Hood for vapour extraction
- Remote-Master® Technology

BAKING DIMENSIONS

Belt width L	500mm
Internal length	590mm
Total length P	1314mm
Total length P with pizza rest	1564mm
Tot. baking surface	0,3m ²

STANDARD EQUIPMENT

- 4 displays
- 20 customisable programs
- **ECO-STAND BY™ TECHNOLOGY** Saving device with the possibility to stop the belt for break
- Discontinuous baking cycle **STEP**
- Double pass baking cycle **RETURN**
- **LOCK** function
- Auto test with display of error message
- Independent maximum temperature safety device
- Stainless steel resting support (+250mm)
- Integrated WiFi module
- SmartBaking app

TOP VIEW

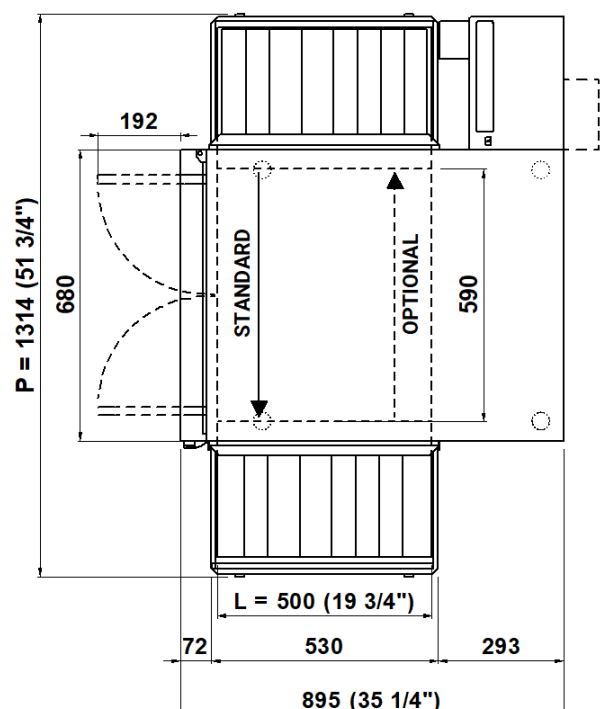

1 baking chamber

(assembled with stand height 600mm)

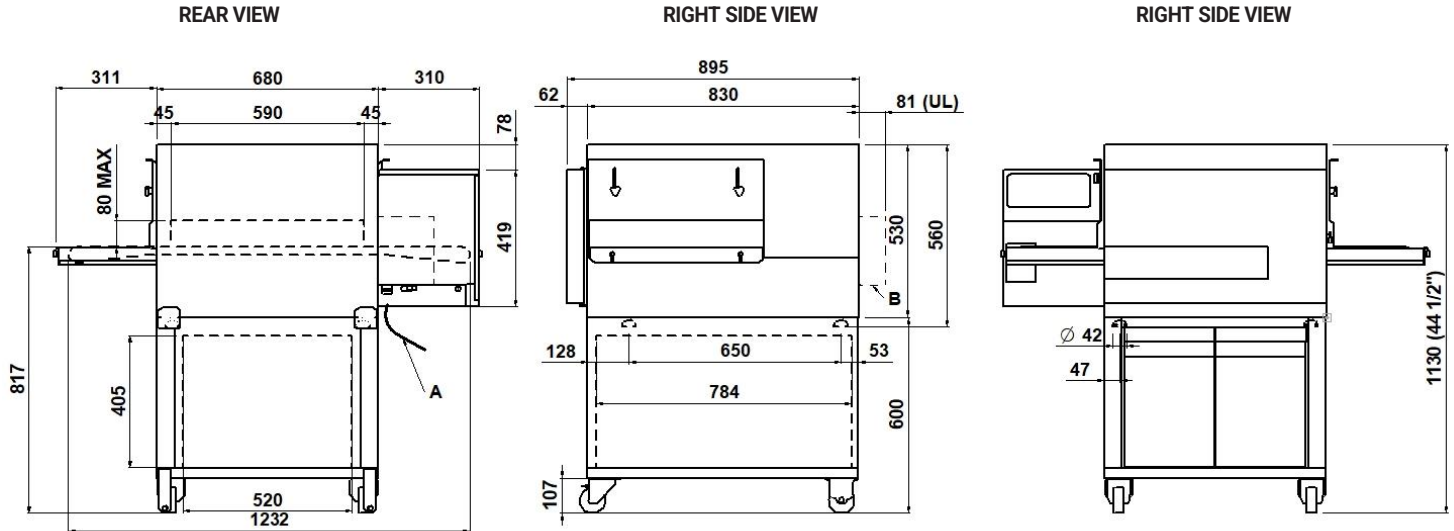

NOTE: The dimensions indicated in the views are in millimeters.

A Electrical cable length 4 meters	B Only for UL model fairlead		
-------------------------------------------------	-------------------------------------------	--	--

DIMENSIONS

External height	1130mm
External depth.	895mm
External width.	1314mm
Weight (excl. stand)	121kg

TOTAL BAKING CAPACITY

*N° Pizzas /hour	
Pizzas diameter 330mm	N°31
Pizzas diameter 450mm	N°20

SHIPPING INFORMATION

Dimensions of packed oven	
Height	705mm
Depth	1020mm
Width	1465mm
Weight	(121+21)kg

Packaged stand dimensions:	
Height	625mm
Depth	745mm
Width	900mm
Weight	(22+7)kg

FEEDING AND POWER

Standard feeding	
A.C. V400 3N	
Feeding on request	
A.C. V230 3 V230 1N	
Frequency	50/60Hz
Max power	8,9kW
*Medium cons/hour	4,5kWh
Connecting cable for each chamber	
tipo H07RN-F	
5x4mm ² (V400 3N)	
4x6 mm ² (V230 3)	
3x10mm ² (V230 1N)	

* This value is subject to variation according to the way in which the equipment is used

NOTE: MORETTI FORNI S.P.A. reserves the right to modify the characteristics of the products illustrated in this publication without prior notice

2 baking chambers

(assembled with stand height 600mm)

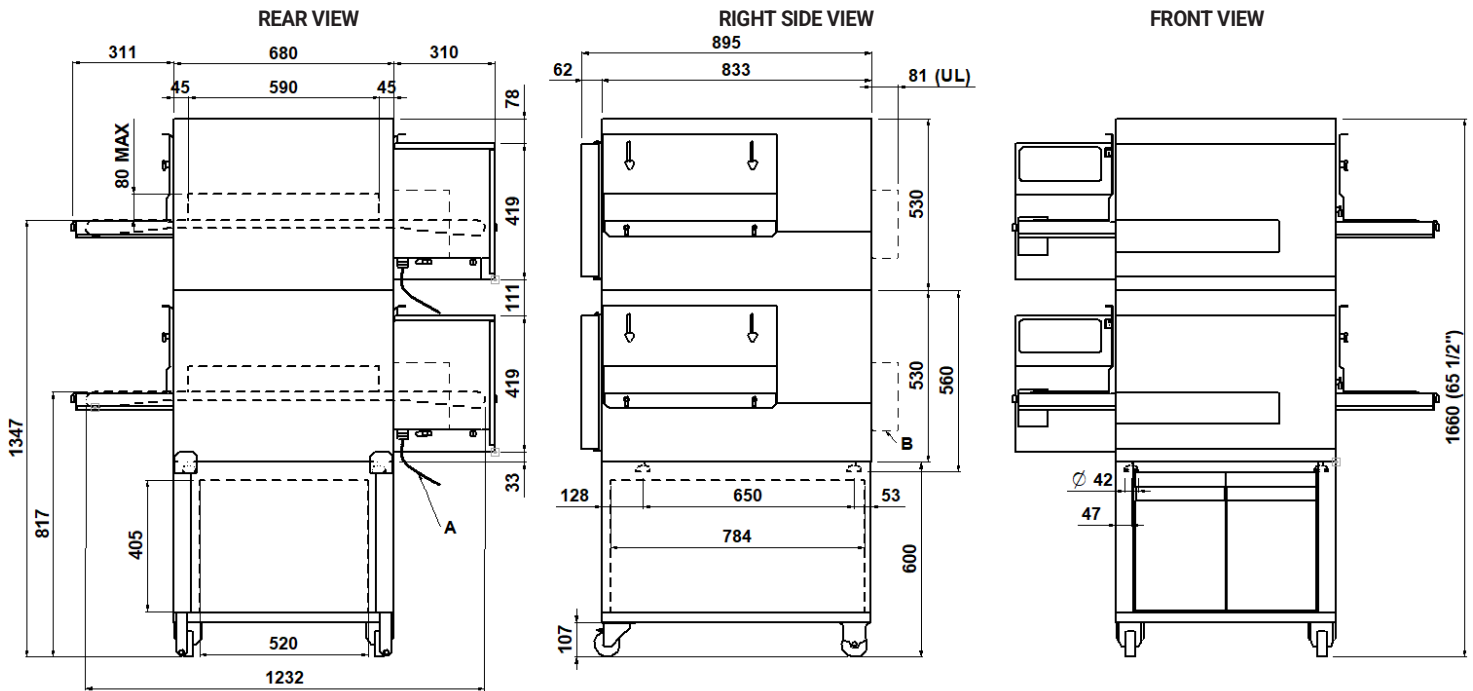

NOTE: The dimensions indicated in the views are in millimeters.

A	B		
Electrical cable length 4 meters	Only for UL model fairleads		

DIMENSIONS

External height	1660mm
External depth	895mm
External width	1314mm
Weight (excl. stand)	242kg

TOTAL BAKING CAPACITY

*N° Pizzas /hour	
Pizzas diameter 330mm	N°62
Pizzas diameter 450mm	N°40

SHIPPING INFORMATION

Packed oven (each packed deck)	
Height	2x705mm
Depth	1020mm
Width	1465mm
Weight	(242+42)kg

Packaged stand dimensions:

Height	625mm
Depth	745mm
Width	900mm
Weight	(22+7)kg

FEEDING AND POWER

Standard feeding	
A.C. V400 3N	
Feeding on request	
A.C. V230 3 V230 1N	
Frequency	50/60Hz
Max power	17,8kW
*Medium cons/hour	9kWh
Connecting cable for each chamber	
tipo H07RN-F	
5x4mm ² (V400 3N)	
4x6 mm ² (V230 3)	
3x10mm ² (V230 1N)	

* This value is subject to variation according to the way in which the equipment is used

NOTE: MORETTI FORNI S.P.A. reserves the right to modify the characteristics of the products illustrated in this publication without prior notice

3 baking chambers
(assembled with stand height 137mm)

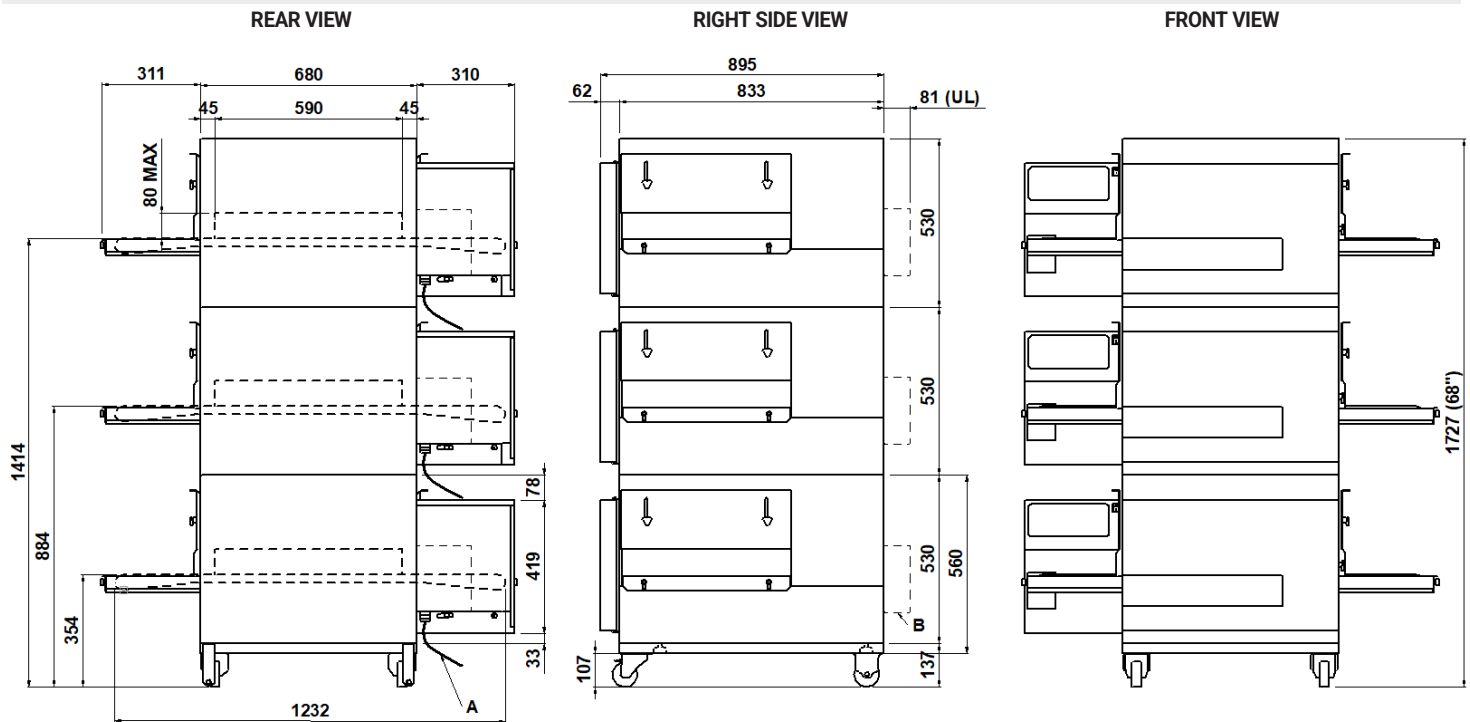

NOTE: The dimensions indicated in the views are in millimeters.

A Electrical cable length 4 meters	B Only for UL model fairleads		
----------------------------------------------	-----------------------------------------	--	--

DIMENSIONS

External height.	1727mm
External depth	895mm
External width	1314mm
Weight(excl.stand)	363kg

SHIPPING INFORMATION

Packed oven (each packed deck)	3x705mm
Height	1020mm
Depth	1465mm
Weight	(363+63)kg

FEEDING AND POWER

Standard feeding	A.C. V400 3N
Feeding on request	A.C. V230 3 V230 1N
Frequency	50/60Hz

TOTAL BAKING CAPACITY

*N° Pizzas /hour	N°93
Pizzas diameter 330mm	N°40
Pizzas diameter 450mm	

Packaged stand dimensions:	
Height	225mm
Depth	735mm
Width	920mm
Weight	(15+3)kg

Max power	26,7kW
*Medium cons/hour	13,5kWh
Connecting cable for each chamber	tipo H07RN-F
	5x4mm ² (V400 3N)
	4x6 mm ² (V230 3)
	3x10mm ² (V230 1N)

* This value is subject to variation according to the way in which the equipment is used
NOTE: MORETTI FORNI S.P.A. reserves the right to modify the characteristics of the products illustrated in this publication without prior notice



Modular conveyor oven

T65E, the electric modular conveyor oven, is composed of one or more **stackable baking chambers** and an optional stand. During baking, the product is placed on the conveyor belt and passes through two flows of hot air: **impingement technology**, the best system for heat distribution in the whole baking chamber for **perfect baking of pizza, pastry, bakery, and gastronomy**. Management of needed power is automatic according to the load. The power control of ceiling and floor is independent and managed by two probes. The conveyor speed is adjustable. Efficiently insulated and isolated, the external surfaces are cool even during use. Installable as countertop or on an optional stand closed by stainless steel doors on swivel castors. The baking chamber maximum temperature is 320°C (608°F).



OPERATION

- Heated by armoured heating elements
- Control of power PID (Proportional Supplementary Derivative) can allow the automatic regulation of energy necessary on the basis of the quantity of the batch product **ADAPTIVE-POWER® TECHNOLOGY**
- Independent adjustment and control of ceiling and floor, with continuous temperature detection using 2 high sensitive thermocouples **DUAL-TEMP® TECHNOLOGY**
- Air blowing system using stainless steel fan
- Conveyor belt with speed adjustable from 30" to 20 minutes and feed-back control at the option of belt standstill
- Programmable electronic function management **ECO-SMARTBAKING®**
- Maximum temperature reached 320°C (608°F)
- Independent system for additional forced air cooling of the components with low noise

CONSTRUCTION

- Structure in folded stainless steel sheets
- Stainless steel door hinged on left hand side with logo **BlackBar® Design**
- Extractable stainless steel conveyor belt, with continuous tensioning
- Electronic control panel on front left side
- Adjustable feet
- Baking chamber in stainless steel sheets
- Top and bottom blowers in welded stainless steel sheets, extractable for cleaning
- Rock wool heat insulation, thermal minijoints and air space **COOL AROUND® Technology**

ACCESSORIES

- Stand with castors, height 137, 600mm
- Loading or unloading roller
- Hood for vapour extraction
- Remote-Master® Technology

BAKING DIMENSIONS

Belt width L	500mm
Internal length	590mm
Total length P	1314mm
Total length P with pizza rest	1564mm
Tot. baking surface	0,3m ²

STANDARD EQUIPMENT

- 4 displays
- 20 customisable programs
- **ECO-STAND BY™ TECHNOLOGY** Saving device with the possibility to stop the belt for break
- Discontinuous baking cycle **STEP**
- Double pass baking cycle **RETURN**
- **LOCK** function
- Auto test with display of error message
- Independent maximum temperature safety device
- Stainless steel resting support (+250mm)
- Integrated WiFi module
- SmartBaking app

TOP VIEW

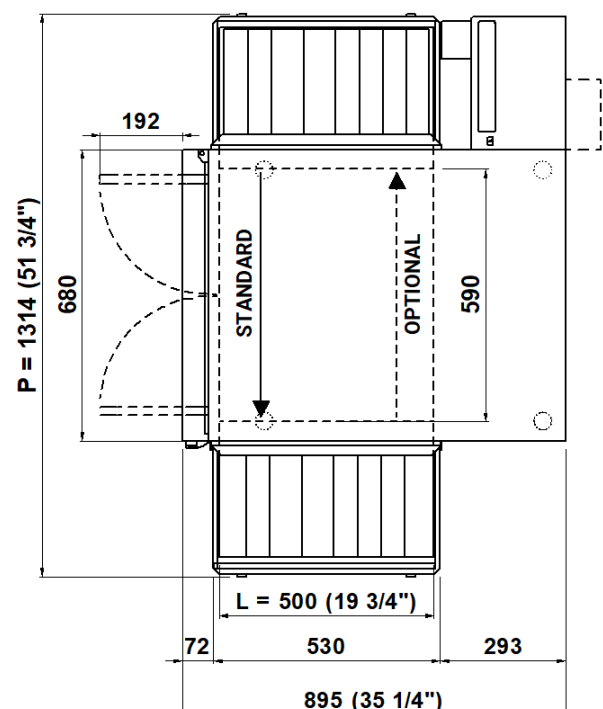

1 baking chamber

(assembled with stand height 600mm)

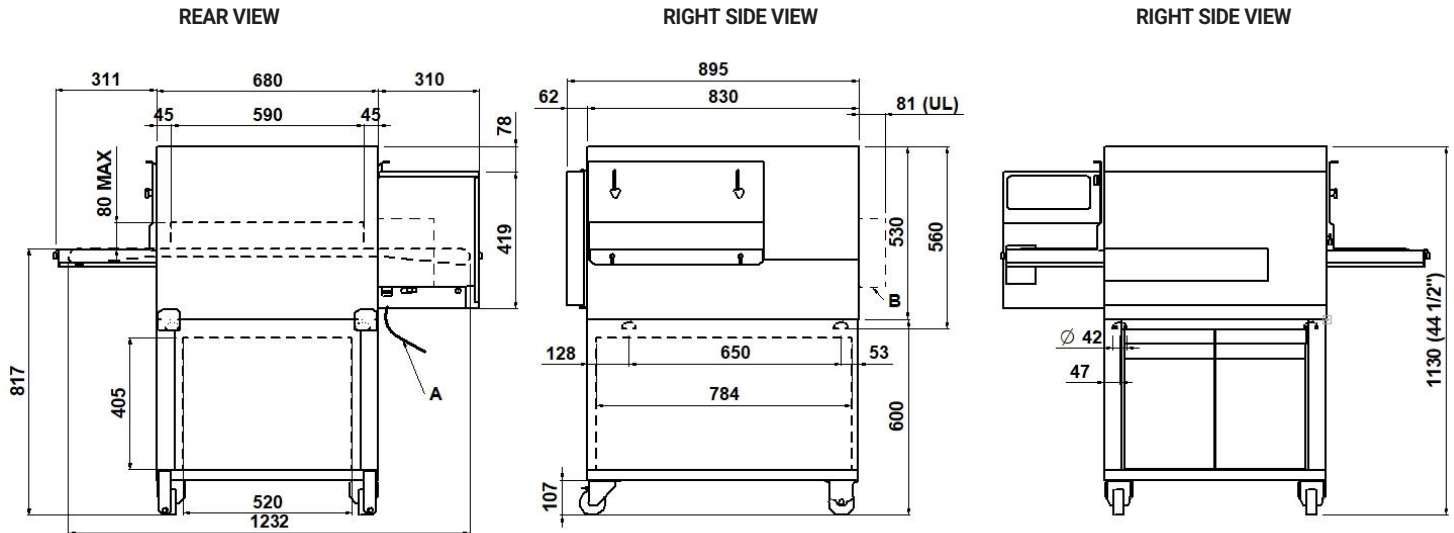

NOTE: The dimensions indicated in the views are in millimeters.

A	B		
Electrical cable length 4 meters	Only for UL model fairlead		

DIMENSIONS

External height	1130mm
External depth.	895mm
External width.	1314mm
Weight (excl. stand)	121kg

TOTAL BAKING CAPACITY

*N° Pizzas /hour	
Pizzas diameter 330mm	N°31
Pizzas diameter 450mm	N°20

SHIPPING INFORMATION

Dimensions of packed oven	
Height	705mm
Depth	1020mm
Width	1465mm
Weight	(121+21)kg

Packaged stand dimensions:	
Height	625mm
Depth	745mm
Width	900mm
Weight	(22+7)kg

FEEDING AND POWER

Standard feeding	
A.C. V400 3N	
Feeding on request	
A.C. V230 3 V230 1N	
Frequency	50/60Hz
Max power	8,9kW
*Medium cons/hour	4,5kWh
Connecting cable for each chamber	
tipo H07RN-F	
5x4mm ² (V400 3N)	
4x6 mm ² (V230 3)	
3x10mm ² (V230 1N)	

* This value is subject to variation according to the way in which the equipment is used

NOTE: MORETTI FORNI S.P.A. reserves the right to modify the characteristics of the products illustrated in this publication without prior notice

2 baking chambers

(assembled with stand height 600mm)

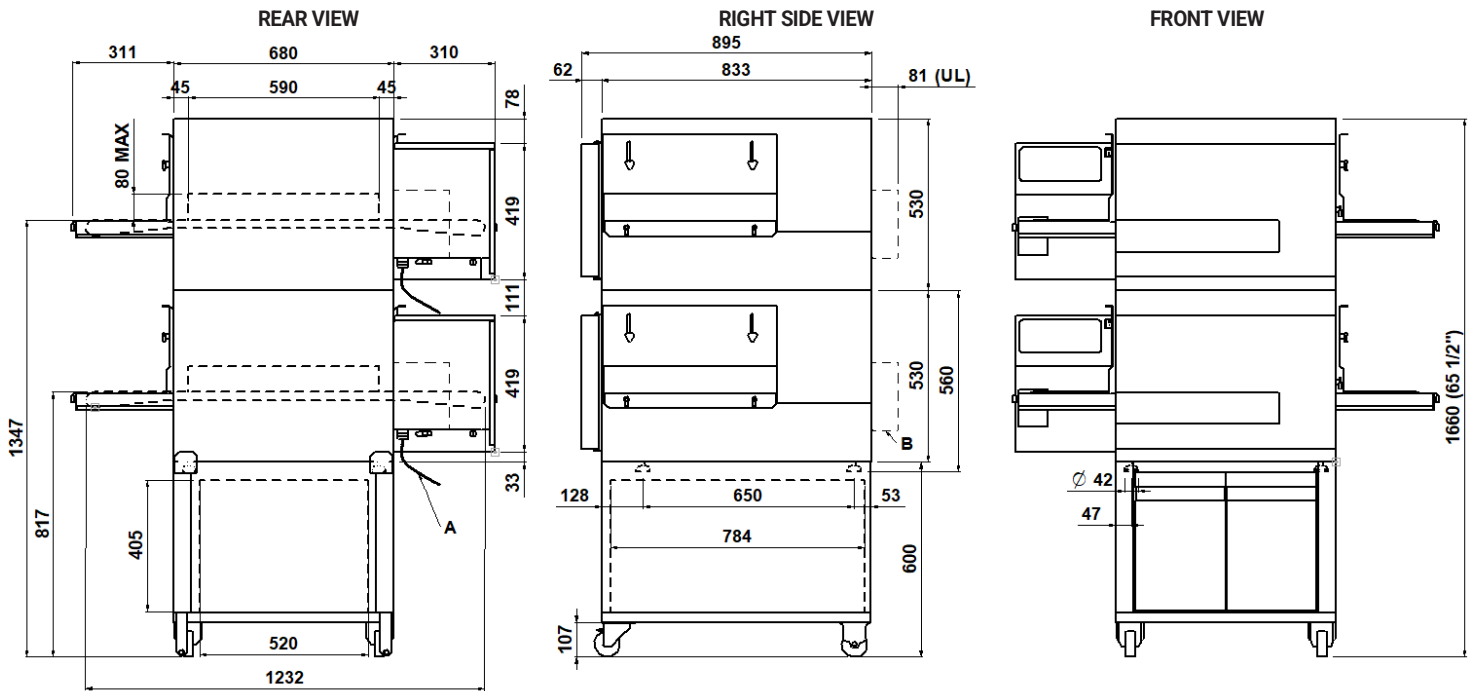

NOTE: The dimensions indicated in the views are in millimeters.

A Electrical cable length 4 meters	B Only for UL model fairleads		
----------------------------------------------	-----------------------------------------	--	--

DIMENSIONS

External height	1660mm
External depth	895mm
External width	1314mm
Weight (excl. stand)	242kg

TOTAL BAKING CAPACITY

*N° Pizzas /hour	
Pizzas diameter 330mm	N°62
Pizzas diameter 450mm	N°40

SHIPPING INFORMATION

Packed oven (each packed deck)	
Height	2x705mm
Depth	1020mm
Width	1465mm
Weight	(242+42)kg

Packaged stand dimensions:

Height	625mm
Depth	745mm
Width	900mm
Weight	(22+7)kg

FEEDING AND POWER

Standard feeding	
A.C. V400 3N	
Feeding on request	
A.C. V230 3 V230 1N	
Frequency	50/60Hz

Max power	17,8kW
*Medium cons/hour	9kWh
Connecting cable for each chamber	
tipo H07RN-F	
5x4mm ² (V400 3N)	
4x6 mm ² (V230 3)	
3x10mm ² (V230 1N)	

* This value is subject to variation according to the way in which the equipment is used
NOTE: MORETTI FORNI S.P.A. reserves the right to modify the characteristics of the products illustrated in this publication without prior notice

3 baking chambers
(assembled with stand height 137mm)

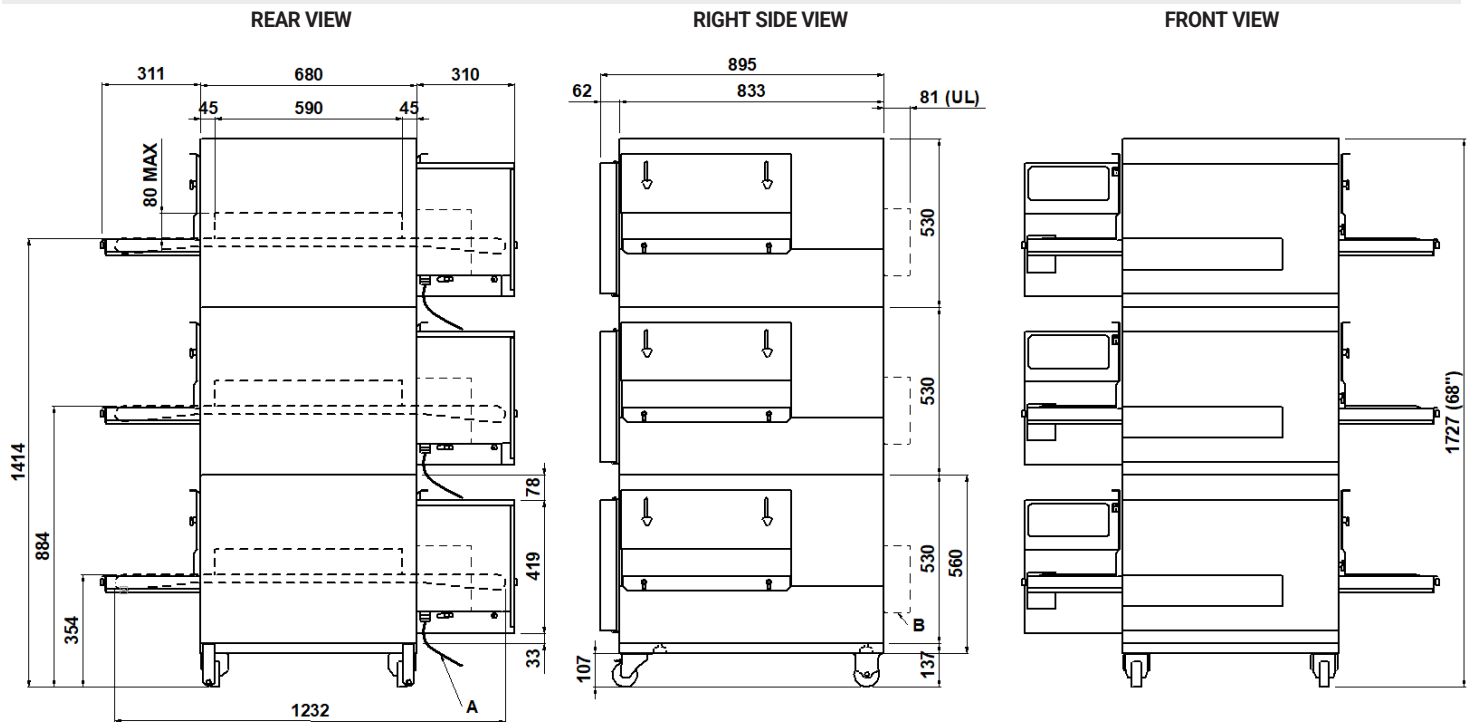

NOTE: The dimensions indicated in the views are in millimeters.

A Electrical cable length 4 meters	B Only for UL model fairleads		
-------------------------------------------------	--------------------------------------------	--	--

DIMENSIONS

External height.	1727mm
External depth	895mm
External width	1314mm
Weight(excl. stand)	363kg

SHIPPING INFORMATION

Packed oven (each packed deck)	3x705mm
Height	1020mm
Depth	1465mm
Weight	(363+63)kg

FEEDING AND POWER

Standard feeding	A.C. V400 3N
Feeding on request	A.C. V230 3 V230 1N
Frequency	50/60Hz

TOTAL BAKING CAPACITY

*N° Pizzas /hour	N°93
Pizzas diameter 330mm	N°40
Pizzas diameter 450mm	

Packaged stand dimensions:	
Height	225mm
Depth	735mm
Width	920mm
Weight	(15+3)kg

Max power	26,7kW
*Medium cons/hour	13,5kWh
Connecting cable for each chamber	tipo H07RN-F
	5x4mm ² (V400 3N)
	4x6 mm ² (V230 3)
	3x10mm ² (V230 1N)

* This value is subject to variation according to the way in which the equipment is used
NOTE: MORETTI FORNI S.P.A. reserves the right to modify the characteristics of the products illustrated in this publication without prior notice



Modular conveyor oven

T65E, the electric modular conveyor oven, is composed of one or more **stackable baking chambers** and an optional stand. During baking, the product is placed on the conveyor belt and passes through two flows of hot air: **impingement technology**, the best system for heat distribution in the whole baking chamber for **perfect baking of pizza, pastry, bakery, and gastronomy**. Management of needed power is automatic according to the load. The power control of ceiling and floor is independent and managed by two probes. The conveyor speed is adjustable. Efficiently insulated and isolated, the external surfaces are cool even during use. Installable as countertop or on an optional stand closed by stainless steel doors on swivel castors. The baking chamber maximum temperature is 320°C (608°F).



OPERATION

- Heated by armoured heating elements
- Control of power PID (Proportional Supplementary Derivative) can allow the automatic regulation of energy necessary on the basis of the quantity of the batch product **ADAPTIVE-POWER® TECHNOLOGY**
- Independent adjustment and control of ceiling and floor, with continuous temperature detection using 2 high sensitive thermocouples **DUAL-TEMP® TECHNOLOGY**
- Air blowing system using stainless steel fan
- Conveyor belt with speed adjustable from 30" to 20 minutes and feed-back control at the option of belt standstill
- Programmable electronic function management **ECO-SMARTBAKING®**
- Maximum temperature reached 320°C (608°F)
- Independent system for additional forced air cooling of the components with low noise

CONSTRUCTION

- Structure in folded stainless steel sheets
- Stainless steel door hinged on left hand side with logo **BlackBar® Design**
- Extractable stainless steel conveyor belt, with continuous tensioning
- Electronic control panel on front left side
- Adjustable feet
- Baking chamber in stainless steel sheets
- Top and bottom blowers in welded stainless steel sheets, extractable for cleaning
- Rock wool heat insulation, thermal minijoints and air space **COOL AROUND® Technology**

ACCESSORIES

- Stand with castors, height 137, 600mm
- Loading or unloading roller
- Hood for vapour extraction
- Remote-Master® Technology

BAKING DIMENSIONS

Belt width L	500mm
Internal length	590mm
Total length P	1314mm
Total length P with pizza rest	1564mm
Tot. baking surface	0,3m ²

STANDARD EQUIPMENT

- 4 displays
- 20 customisable programs
- **ECO-STAND BY™ TECHNOLOGY** Saving device with the possibility to stop the belt for break
- Discontinuous baking cycle **STEP**
- Double pass baking cycle **RETURN**
- **LOCK** function
- Auto test with display of error message
- Independent maximum temperature safety device
- Stainless steel resting support (+250mm)
- Integrated WiFi module
- SmartBaking app

TOP VIEW

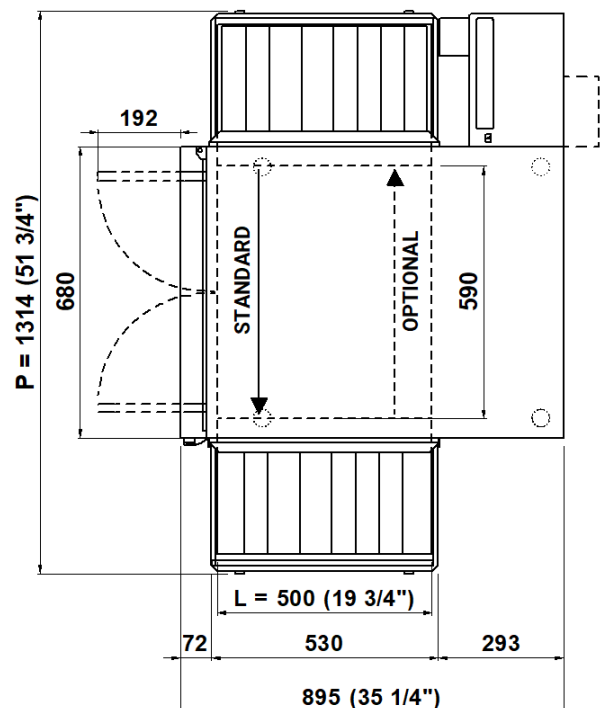

1 baking chamber

(assembled with stand height 600mm)

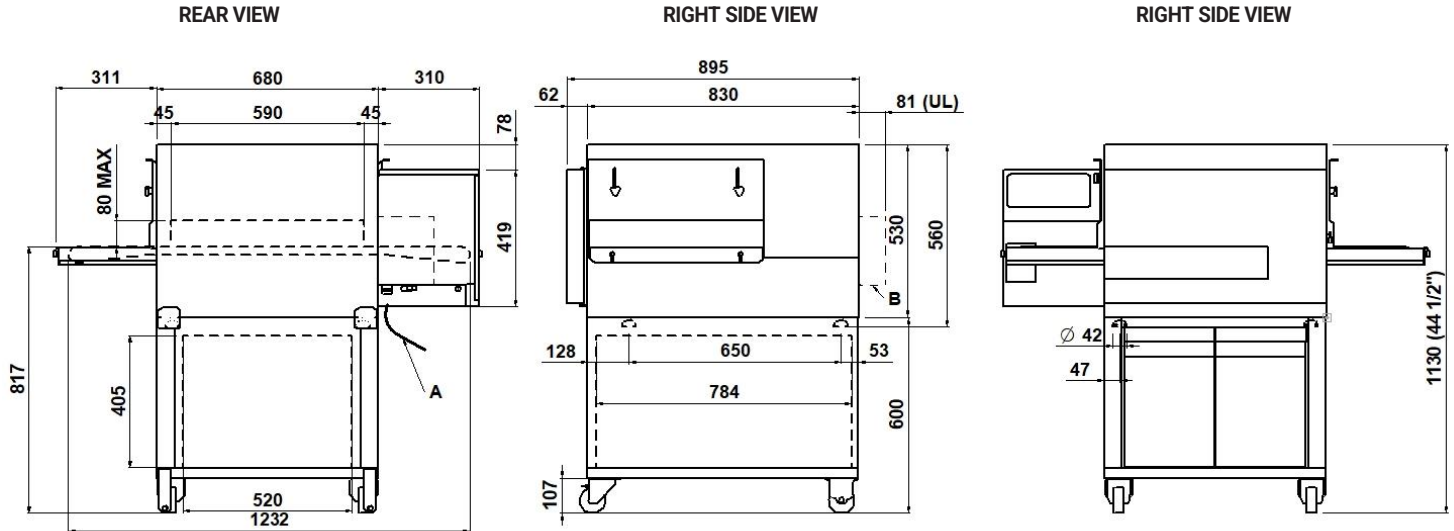

NOTE: The dimensions indicated in the views are in millimeters.

A Electrical cable length 4 meters	B Only for UL model fairlead		
-------------------------------------------------	-------------------------------------------	--	--

DIMENSIONS

External height	1130mm
External depth.	895mm
External width.	1314mm
Weight (excl. stand)	121kg

TOTAL BAKING CAPACITY

*N° Pizzas /hour	
Pizzas diameter 330mm	N°31
Pizzas diameter 450mm	N°20

SHIPPING INFORMATION

Dimensions of packed oven	
Height	705mm
Depth	1020mm
Width	1465mm
Weight	(121+21)kg

Packaged stand dimensions:	
Height	625mm
Depth	745mm
Width	900mm
Weight	(22+7)kg

FEEDING AND POWER

Standard feeding	
A.C. V400 3N	
Feeding on request	
A.C. V230 3 V230 1N	
Frequency	50/60Hz
Max power	8,9kW
*Medium cons/hour	4,5kWh
Connecting cable for each chamber	
tipo H07RN-F	
5x4mm ² (V400 3N)	
4x6 mm ² (V230 3)	
3x10mm ² (V230 1N)	

* This value is subject to variation according to the way in which the equipment is used

NOTE: MORETTI FORNI S.P.A. reserves the right to modify the characteristics of the products illustrated in this publication without prior notice

2 baking chambers

(assembled with stand height 600mm)

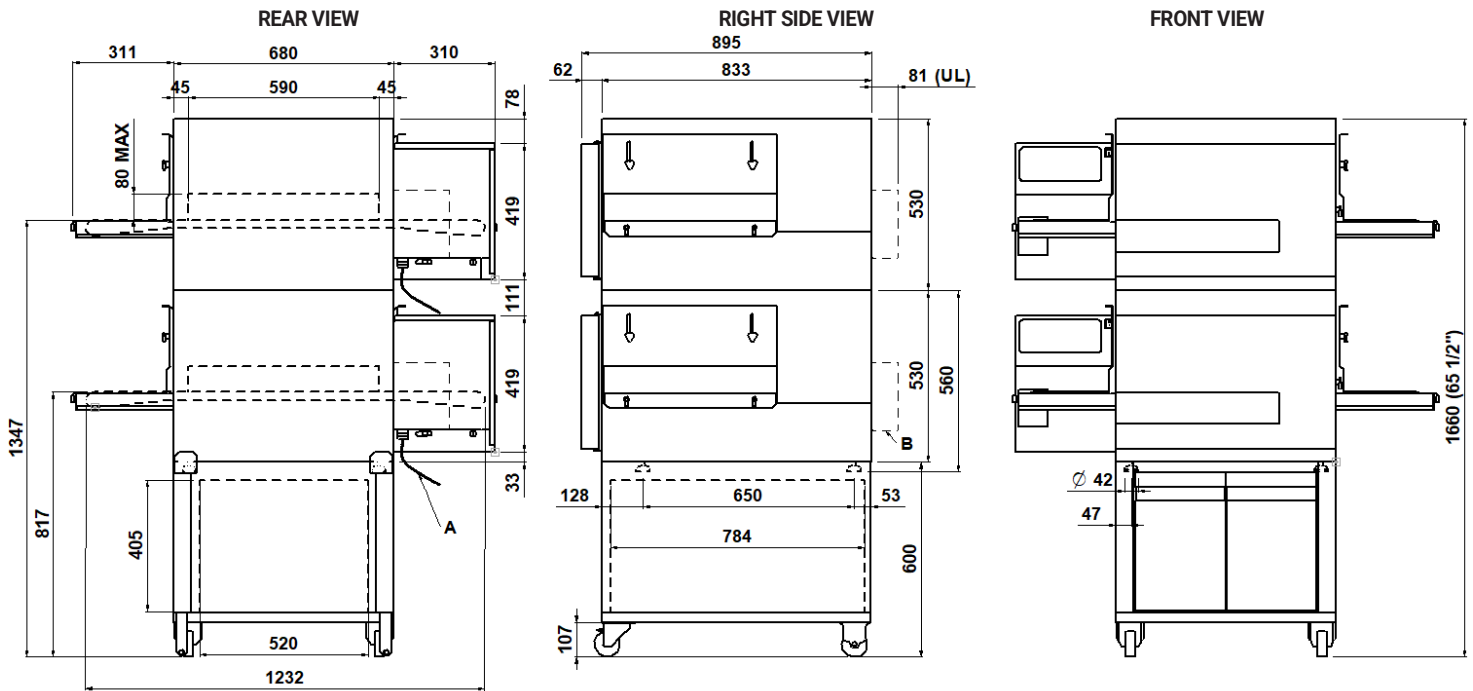

NOTE: The dimensions indicated in the views are in millimeters.

A	B		
Electrical cable length 4 meters	Only for UL model fairleads		

DIMENSIONS

External height	1660mm
External depth	895mm
External width	1314mm
Weight (excl. stand)	242kg

TOTAL BAKING CAPACITY

*N° Pizzas /hour	
Pizzas diameter 330mm	N°62
Pizzas diameter 450mm	N°40

SHIPPING INFORMATION

Packed oven (each packed deck)	
Height	2x705mm
Depth	1020mm
Width	1465mm
Weight	(242+42)kg

Packaged stand dimensions:

Height	625mm
Depth	745mm
Width	900mm
Weight	(22+7)kg

FEEDING AND POWER

Standard feeding	
A.C. V400 3N	
Feeding on request	
A.C. V230 3 V230 1N	
Frequency	50/60Hz

Max power	17,8kW
*Medium cons/hour	9kWh
Connecting cable for each chamber	
tipo H07RN-F	
5x4mm ² (V400 3N)	
4x6 mm ² (V230 3)	
3x10mm ² (V230 1N)	

* This value is subject to variation according to the way in which the equipment is used
NOTE: MORETTI FORNI S.P.A. reserves the right to modify the characteristics of the products illustrated in this publication without prior notice

3 baking chambers
(assembled with stand height 137mm)

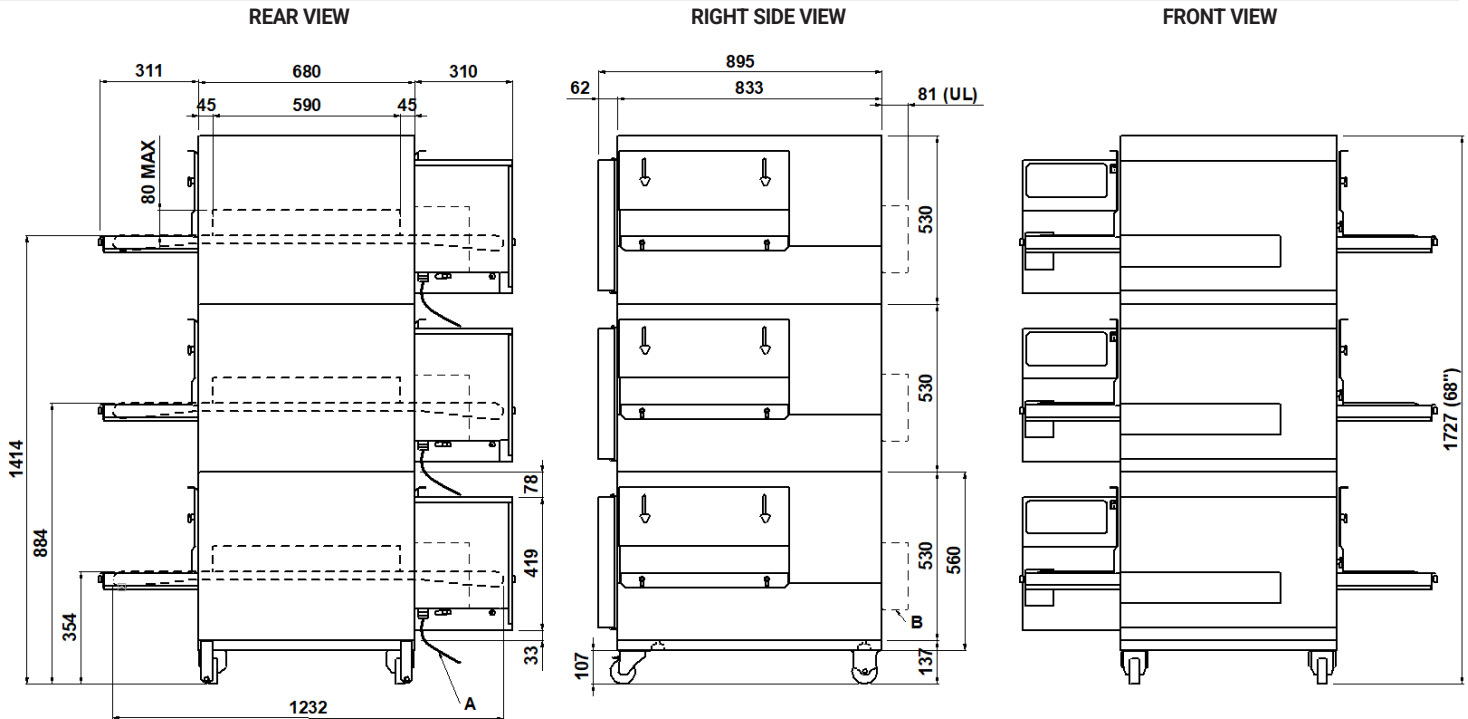

NOTE: The dimensions indicated in the views are in millimeters.

A Electrical cable length 4 meters	B Only for UL model fairleads		
----------------------------------------------	-----------------------------------------	--	--

DIMENSIONS

External height.	1727mm
External depth	895mm
External width	1314mm
Weight(excl. stand)	363kg

TOTAL BAKING CAPACITY

*N° Pizzas /hour	
Pizzas diameter 330mm	N°93
Pizzas diameter 450mm	N°40

SHIPPING INFORMATION

Packed oven (each packed deck)	3x705mm
Height	1020mm
Depth	1465mm
Weight	(363+63)kg

Packaged stand dimensions:

Height	225mm
Depth	735mm
Width	920mm
Weight	(15+3)kg

FEEDING AND POWER

Standard feeding	
A.C. V400 3N	
Feeding on request	
A.C. V230 3 V230 1N	
Frequency	50/60Hz

Max power	26,7kW
*Medium cons/hour	13,5kWh
Connecting cable for each chamber	
tipo H07RN-F	
5x4mm ² (V400 3N)	
4x6 mm ² (V230 3)	
3x10mm ² (V230 1N)	

* This value is subject to variation according to the way in which the equipment is used
NOTE: MORETTI FORNI S.P.A. reserves the right to modify the characteristics of the products illustrated in this publication without prior notice