



Modular conveyor oven

TT98G, the gas modular conveyor oven, is composed of one or more **stackable baking chambers** and an optional stand. During baking, the product is placed on the conveyor belt and passes through two flows of hot air: **impingement technology**, the best system for heat distribution in the whole baking chamber for **perfect baking of pizza, pastry, bakery, and gastronomy**. Efficiently insulated and isolated, the external surfaces are cool even during use. The baking chamber maximum temperature is 320°C (608°F).



OPERATION

- Heating by means of two blowing burners with premixing function of air and gas
- Electronically modulated control of two burners flames that allows the automatic energy control on the strength of the quantity of the baked product and the position located inside the baking chamber ADAPTIVE-GAS® TECHNOLOGY
- Independent regulation and control both the input side and the output side of the baked product with continuous temperatures survey with 2 high sensitive thermocouples DUAL-TEMP® TECHNOLOGY
- Air blowing system using 2 stainless steel fans independently motorized
- Conveyor belt with speed adjustable from 2 to 20 minutes and feed-back control at the option of belt standstill
- Programmable electronic function management ECO-SMARTBAKING®
- Different baking heating regulations between upper and lower part of the product DUAL FLOW® TECHNOLOGY
- Maximum temperature reached 320°C (608°F)
- Independent system for additional forced air cooling of the components with low noise

CONSTRUCTION

- Structure in folded stainless steel sheets
- Stainless steel door hinged on left hand side with logo BlackBar® Design
- Stainless steel access flap hinged at bottom
- Tempered glass window
- Low-cluttered handle
- Extractable stainless steel conveyor belt, with continuous tensioning
- Electronic control panel on front left side
- Double Peephole for checking the burner status
- Baking chamber in stainless steel sheets
- Top and bottom blowers in welded stainless steel sheets, extractable for cleaning
- Double Low-emission (NOx, CO) stainless steel burner
- Double Combustion chamber entirely built with special high-temperatures stainless steel
- Rock wool heat insulation, thermal joints and air space COOL AROUND® Technology

ACCESSORIES

- Stand with castors, height 153, 600mm complete with pocket for screens
- Remote-Master® Technology
- Thick mesh for direct baking of low-moisture doughs or for grilling vegetables
- Fast tape adjustable from 45 seconds to 10 minutes

BAKING DIMENSIONS

Belt width L	810mm
Internal length	910mm
Total length P	2050mm
Total length P with pizza rest	2475mm
Tot. baking surface	0,74m ²

STANDARD EQUIPMENT

- Color multilanguage display TFT 5"
- 100 customisable programs
- ECO-STAND BY™ TECHNOLOGY Saving device with the possibility to stop the belt for break
- Discontinuous baking cycle STEP
- Start-Stop function to move tape to the set point is reached
- LOCK function
- Customized Hotkey with recurring control
- Auto test with display of error message
- USB input and wifi module for sw update
- Double independent maximum temperature and minimum blow pressure safety devices
- Stainless steel resting support (+475mm)
- SmartBaking app

TOP VIEW

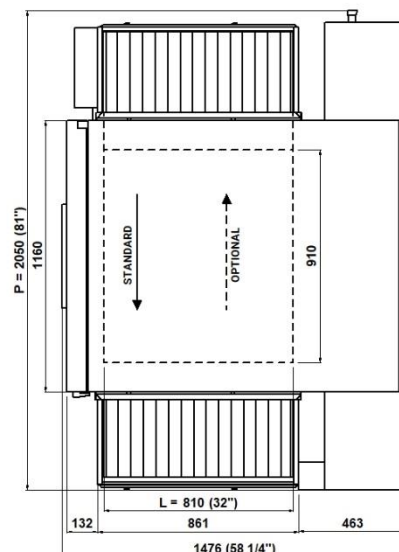

1 baking chamber
(assembled with stand height 600mm)

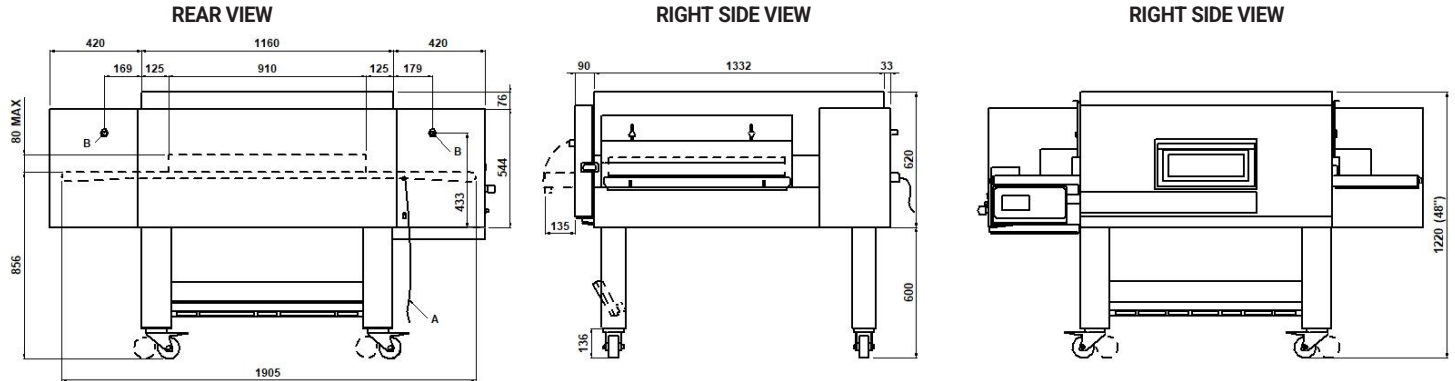

NOTE: The dimensions indicated in the views are in millimeters.

A Electrical cable length 2 meters	B Cone-shaped male gas manifold 3/4" GAS		
---	---	--	--

DIMENSIONS

External height	1220mm
External depth.	1476mm
External width.	2050mm
Weight (excl. stand)	365kg

TOTAL BAKING CAPACITY

*N° Pizzas /hour	
Pizzas diameter 330mm	N°125
Pizzas diameter 450mm	N°48

SHIPPING INFORMATION

Dimensions of packed oven	
Height	790mm
Depth	1725mm
Width	2152mm
Weight	(365+30)kg

Packaged stand dimensions:

Height	200mm
Depth	600mm
Width	1150mm
Weight	(28+2)kg

FEEDING AND POWER

Type of equipment	A3-B23
Thermic power max	30kW
Therm. power reduced	7,5kW
Gas power: NATURAL GAS or LPG	
*Hour consumption max	
Natural gas G20	3,174m ³ /h
Natural gas G25	3,69m ³ /h
Natural gas G25.1	3,686m ³ /h
Natural gas G25.3	3,61m ³ /h
LPG G30	2,366kg/h
LPG G31	2,331kg/h
Standard electric power	
A.C. V230 1N	
Frequency	50/60Hz
Electric power	0,7kW
Connecting cable for each chamber type:	
H07RN-F	3x1,5mm ²

* This value is subject to variation according to the way in which the equipment is used

NOTE: MORETTI FORNI S.P.A. reserves the right to modify the characteristics of the products illustrated in this publication without prior notice

2 baking chambers
(assembled with stand height 600mm)

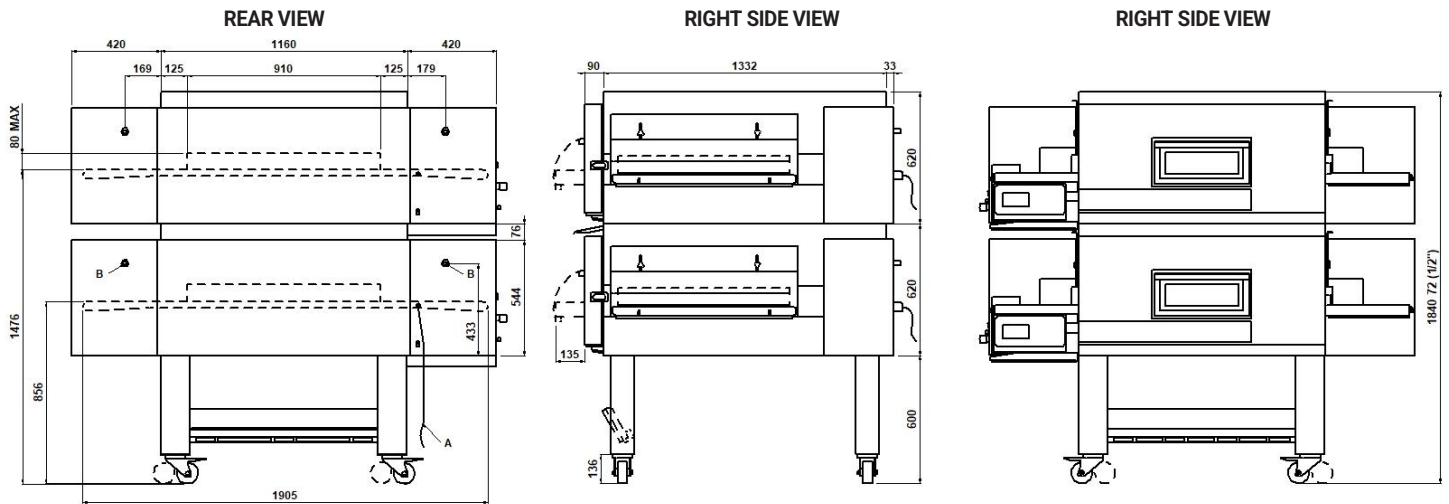

NOTE: The dimensions indicated in the views are in millimeters.

A	B		
Electrical cable length 2 meters	Cone-shaped male gas manifold 3/4" GAS		

DIMENSIONS

External height	1840mm
External depth.	1476mm
External width.	2050mm
Weight (excl. stand)	730kg

TOTAL BAKING CAPACITY

*N° Pizzas /hour	
Pizzas diameter 330mm	N°250
Pizzas diameter 450mm	N°96

SHIPPING INFORMATION

Packed oven (each packed deck)	
Height	2x790mm
Depth	1725mm
Width	2152mm
Weight	(730+60)kg

Packaged stand dimensions:

Height	200mm
Depth	600mm
Width	1150mm
Weight	(28+2)kg

FEEDING AND POWER

Type of equipment	A3-B23
Thermic power max	60kW
Therm. power reduced	15kW
Gas power: NATURAL GAS or LPG	
*Hour consumption max	
Natural gas G20	6,348m ³ /h
Natural gas G25	7,38m ³ /h
Natural gas G25.1	7,372m ³ /h
Natural gas G25.3	7,22m ³ /h
LPG G30	4,732kg/h
LPG G31	4,662kg/h
Standard electric power	
A.C. V230 1N	
Frequency	50/60Hz
Electric power	1,4kW
Connecting cable for each chamber type:	
H07RN-F	3x1,5mm ²

* This value is subject to variation according to the way in which the equipment is used
NOTE: MORETTI FORNI S.P.A. reserves the right to modify the characteristics of the products illustrated in this publication without prior notice

3 baking chambers
(assembled with stand height 153mm)

REAR VIEW

RIGHT SIDE VIEW

RIGHT SIDE VIEW

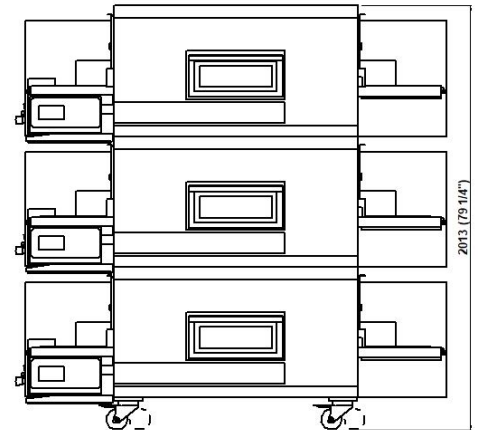
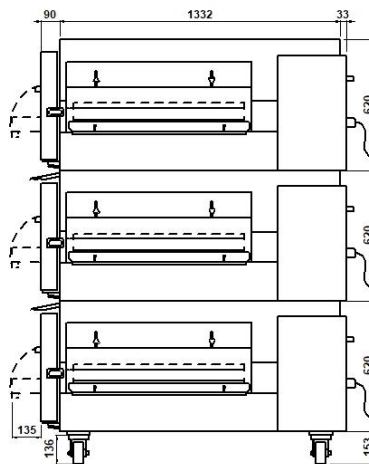
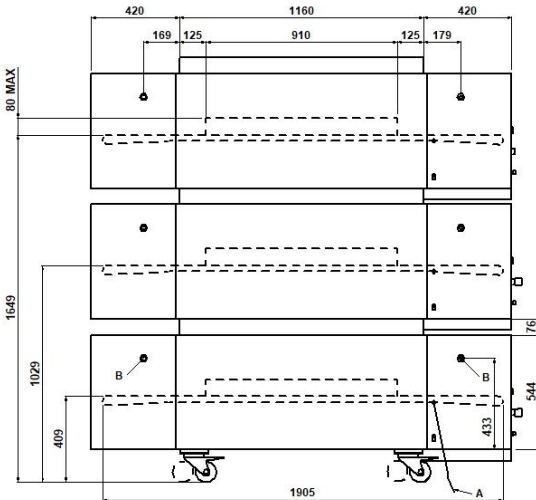

NOTE: The dimensions indicated in the views are in millimeters.

A

Electrical cable
length 2 meters

B

Cone-shaped male gas manifold
3/4" GAS

DIMENSIONS

External height	2013mm
External depth.	1476mm
External width.	2050mm
Weight (excl. stand)	1095kg

TOTAL BAKING CAPACITY

*N° Pizzas /hour	
Pizzas diameter 330mm	N°375
Pizzas diameter 450mm	N°144

SHIPPING INFORMATION

Packed oven (each packed deck)	3x790mm
Height	1725mm
Depth	2152mm
Width	(1095+90)kg
Weight	

Packaged stand dimensions:

Height	280mm
Depth	420mm
Width	270mm
Weight	(16+1)kg

FEEDING AND POWER

Type of equipment	A3-B23
Thermic power max	90kW
Therm. power reduced	22,5kW
Gas power: NATURAL GAS or LPG	
*Hour consumption max	
Natural gas G20	9,522m ³ /h
Natural gas G25	11,07m ³ /h
Natural gas G25.1	11,058m ³ /h
Natural gas G25.3	10,83m ³ /h
LPG G30	7,098kg/h
LPG G31	6,993kg/h
Standard electric power	
A.C. V230 1N	
Frequency	50/60Hz
Electric power	2,1kW
Connecting cable for each chamber type:	
H07RN-F	3x1,5mm ²

* This value is subject to variation according to the way in which the equipment is used

NOTE: MORETTI FORNI S.P.A. reserves the right to modify the characteristics of the products illustrated in this publication without prior notice



Modular conveyor oven

TT98G, the gas modular conveyor oven, is composed of one or more **stackable baking chambers** and an optional stand. During baking, the product is placed on the conveyor belt and passes through two flows of hot air: **impingement technology**, the best system for heat distribution in the whole baking chamber for **perfect baking of pizza, pastry, bakery, and gastronomy**. Efficiently insulated and isolated, the external surfaces are cool even during use. The baking chamber maximum temperature is 320°C (608°F).



OPERATION

- Heating by means of two blowing burners with premixing function of air and gas
- Electronically modulated control of two burners flames that allows the automatic energy control on the strength of the quantity of the baked product and the position located inside the baking chamber ADAPTIVE-GAS® TECHNOLOGY
- Independent regulation and control both the input side and the output side of the baked product with continuous temperatures survey with 2 high sensitive thermocouples DUAL-TEMP® TECHNOLOGY
- Air blowing system using 2 stainless steel fans independently motorized
- Conveyor belt with speed adjustable from 2 to 20 minutes and feed-back control at the option of belt standstill
- Programmable electronic function management ECO-SMARTBAKING®
- Different baking heating regulations between upper and lower part of the product DUAL FLOW® TECHNOLOGY
- Maximum temperature reached 320°C (608°F)
- Independent system for additional forced air cooling of the components with low noise

CONSTRUCTION

- Structure in folded stainless steel sheets
- Stainless steel door hinged on left hand side with logo BlackBar® Design
- Stainless steel access flap hinged at bottom
- Tempered glass window
- Low-cluttered handle
- Extractable stainless steel conveyor belt, with continuous tensioning
- Electronic control panel on front left side
- Double Peephole for checking the burner status
- Baking chamber in stainless steel sheets
- Top and bottom blowers in welded stainless steel sheets, extractable for cleaning
- Double Low-emission (NOx, CO) stainless steel burner
- Double Combustion chamber entirely built with special high-temperatures stainless steel
- Rock wool heat insulation, thermal joints and air space COOL AROUND® Technology

ACCESSORIES

- Stand with castors, height 153, 600mm complete with pocket for screens
- Remote-Master® Technology
- Thick mesh for direct baking of low-moisture doughs or for grilling vegetables
- Fast tape adjustable from 45 seconds to 10 minutes

BAKING DIMENSIONS

Belt width L	810mm
Internal length	910mm
Total length P	2050mm
Total length P with pizza rest	2475mm
Tot. baking surface	0,74m ²

STANDARD EQUIPMENT

- Color multilanguage display TFT 5"
- 100 customisable programs
- ECO-STAND BY™ TECHNOLOGY Saving device with the possibility to stop the belt for break
- Discontinuous baking cycle STEP
- Start-Stop function to move tape to the set point is reached
- LOCK function
- Customized Hotkey with recurring control
- Auto test with display of error message
- USB input and wifi module for sw update
- Double independent maximum temperature and minimum blow pressure safety devices
- Stainless steel resting support (+475mm)
- SmartBaking app

TOP VIEW

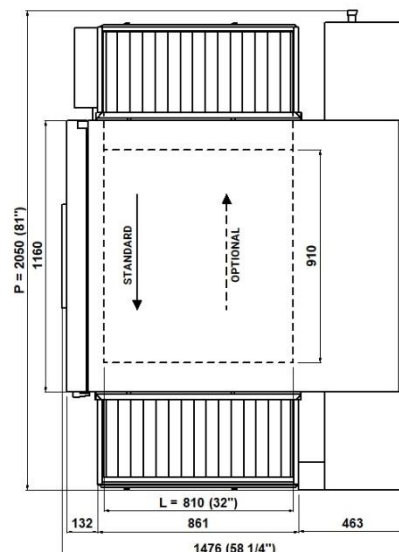

1 baking chamber
(assembled with stand height 600mm)

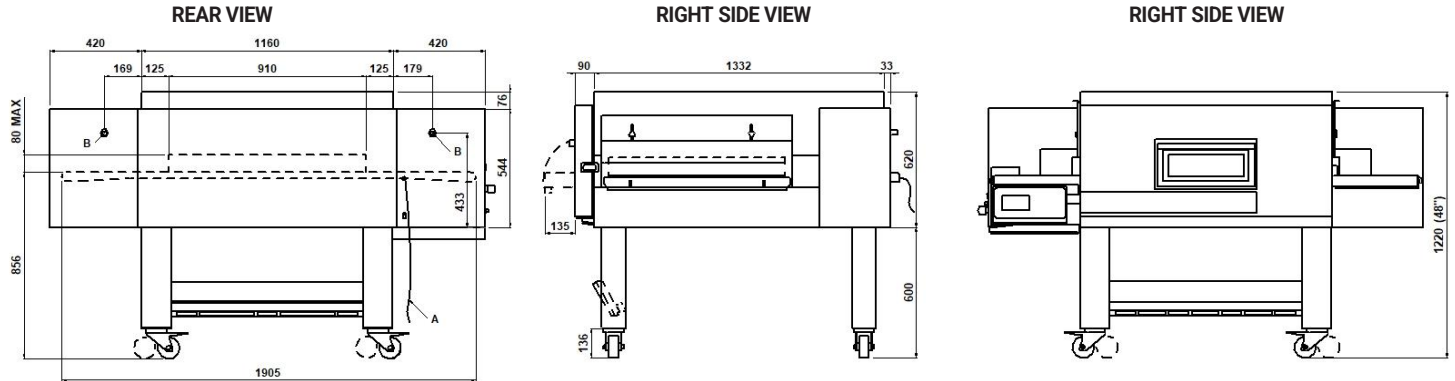

NOTE: The dimensions indicated in the views are in millimeters.

A Electrical cable length 2 meters	B Cone-shaped male gas manifold 3/4" GAS		
---	---	--	--

DIMENSIONS

External height	1220mm
External depth.	1476mm
External width.	2050mm
Weight (excl. stand)	365kg

TOTAL BAKING CAPACITY

*N° Pizzas /hour	
Pizzas diameter 330mm	N°125
Pizzas diameter 450mm	N°48

SHIPPING INFORMATION

Dimensions of packed oven	
Height	790mm
Depth	1725mm
Width	2152mm
Weight	(365+30)kg

Packaged stand dimensions:

Height	200mm
Depth	600mm
Width	1150mm
Weight	(28+2)kg

FEEDING AND POWER

Type of equipment	A3-B23
Thermic power max	30kW
Therm. power reduced	7,5kW
Gas power: NATURAL GAS or LPG	
*Hour consumption max	
Natural gas G20	3,174m ³ /h
Natural gas G25	3,69m ³ /h
Natural gas G25.1	3,686m ³ /h
Natural gas G25.3	3,61m ³ /h
LPG G30	2,366kg/h
LPG G31	2,331kg/h
Standard electric power	
A.C. V230 1N	
Frequency	50/60Hz
Electric power	0,7kW
Connecting cable for each chamber type:	
H07RN-F	3x1,5mm ²

* This value is subject to variation according to the way in which the equipment is used

NOTE: MORETTI FORNI S.P.A. reserves the right to modify the characteristics of the products illustrated in this publication without prior notice

2 baking chambers
(assembled with stand height 600mm)

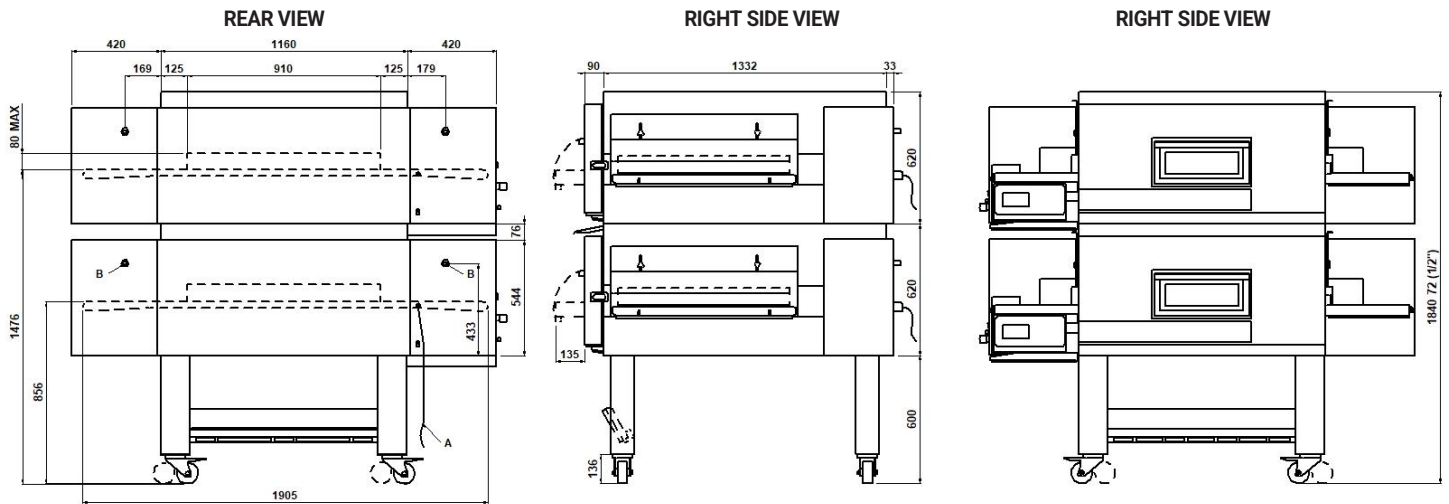

NOTE: The dimensions indicated in the views are in millimeters.

A Electrical cable length 2 meters	B Cone-shaped male gas manifold 3/4" GAS		
---	---	--	--

DIMENSIONS

External height	1840mm
External depth.	1476mm
External width.	2050mm
Weight (excl. stand)	730kg

TOTAL BAKING CAPACITY

*N° Pizzas /hour	
Pizzas diameter 330mm	N°250
Pizzas diameter 450mm	N°96

SHIPPING INFORMATION

Packed oven (each packed deck)	
Height	2x790mm
Depth	1725mm
Width	2152mm
Weight	(730+60)kg

Packaged stand dimensions:

Height	200mm
Depth	600mm
Width	1150mm
Weight	(28+2)kg

FEEDING AND POWER

Type of equipment	A3-B23
Thermic power max	60kW
Therm. power reduced	15kW
Gas power: NATURAL GAS or LPG	
*Hour consumption max	
Natural gas G20	6,348m ³ /h
Natural gas G25	7,38m ³ /h
Natural gas G25.1	7,372m ³ /h
Natural gas G25.3	7,22m ³ /h
LPG G30	4,732kg/h
LPG G31	4,662kg/h
Standard electric power	
A.C. V230 1N	
Frequency	50/60Hz
Electric power	1,4kW
Connecting cable for each chamber type:	
H07RN-F	3x1,5mm ²

* This value is subject to variation according to the way in which the equipment is used
NOTE: MORETTI FORNI S.P.A. reserves the right to modify the characteristics of the products illustrated in this publication without prior notice

3 baking chambers
(assembled with stand height 153mm)

REAR VIEW

RIGHT SIDE VIEW

RIGHT SIDE VIEW

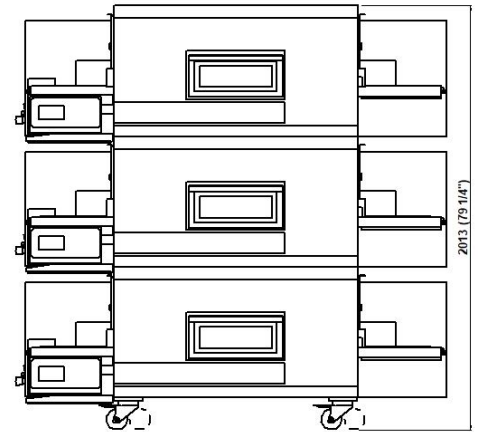
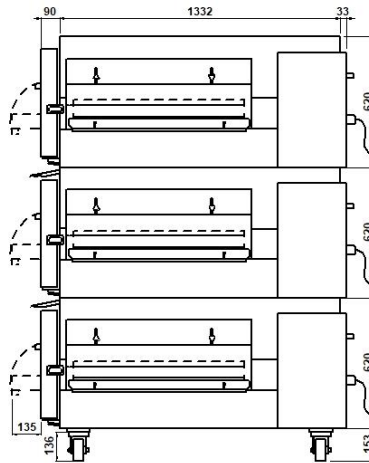
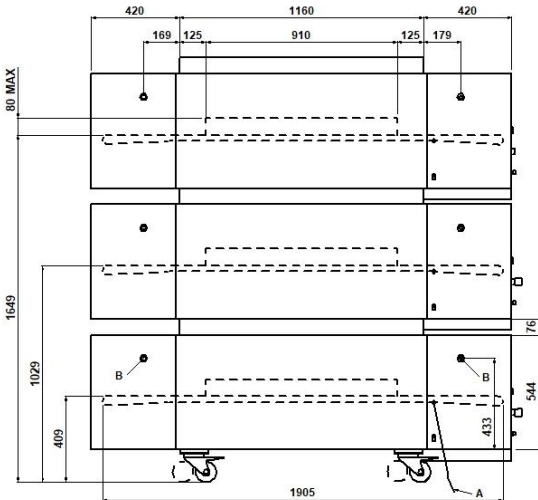

NOTE: The dimensions indicated in the views are in millimeters.

A

Electrical cable
length 2 meters

B

Cone-shaped male gas manifold
3/4" GAS

DIMENSIONS

External height	2013mm
External depth.	1476mm
External width.	2050mm
Weight (excl. stand)	1095kg

TOTAL BAKING CAPACITY

*N° Pizzas /hour	
Pizzas diameter 330mm	N°375
Pizzas diameter 450mm	N°144

SHIPPING INFORMATION

Packed oven (each packed deck)	3x790mm
Height	1725mm
Depth	2152mm
Width	(1095+90)kg
Weight	

Packaged stand dimensions:

Height	280mm
Depth	420mm
Width	270mm
Weight	(16+1)kg

FEEDING AND POWER

Type of equipment	A3-B23
Thermic power max	90kW
Therm. power reduced	22,5kW
Gas power: NATURAL GAS or LPG	
*Hour consumption max	
Natural gas G20	9,522m ³ /h
Natural gas G25	11,07m ³ /h
Natural gas G25.1	11,058m ³ /h
Natural gas G25.3	10,83m ³ /h
LPG G30	7,098kg/h
LPG G31	6,993kg/h
Standard electric power	
A.C. V230 1N	
Frequency	50/60Hz
Electric power	2,1kW
Connecting cable for each chamber type:	
H07RN-F	3x1,5mm ²

* This value is subject to variation according to the way in which the equipment is used

NOTE: MORETTI FORNI S.P.A. reserves the right to modify the characteristics of the products illustrated in this publication without prior notice



Modular conveyor oven

TT98G, the gas modular conveyor oven, is composed of one or more **stackable baking chambers** and an optional stand. During baking, the product is placed on the conveyor belt and passes through two flows of hot air: **impingement technology**, the best system for heat distribution in the whole baking chamber for **perfect baking of pizza, pastry, bakery, and gastronomy**. Efficiently insulated and isolated, the external surfaces are cool even during use. The baking chamber maximum temperature is 320°C (608°F).



OPERATION

- Heating by means of two blowing burners with premixing function of air and gas
- Electronically modulated control of two burners flames that allows the automatic energy control on the strength of the quantity of the baked product and the position located inside the baking chamber ADAPTIVE-GAS® TECHNOLOGY
- Independent regulation and control both the input side and the output side of the baked product with continuous temperatures survey with 2 high sensitive thermocouples DUAL-TEMP® TECHNOLOGY
- Air blowing system using 2 stainless steel fans independently motorized
- Conveyor belt with speed adjustable from 2 to 20 minutes and feed-back control at the option of belt standstill
- Programmable electronic function management ECO-SMARTBAKING®
- Different baking heating regulations between upper and lower part of the product DUAL FLOW® TECHNOLOGY
- Maximum temperature reached 320°C (608°F)
- Independent system for additional forced air cooling of the components with low noise

CONSTRUCTION

- Structure in folded stainless steel sheets
- Stainless steel door hinged on left hand side with logo BlackBar® Design
- Stainless steel access flap hinged at bottom
- Tempered glass window
- Low-cluttered handle
- Extractable stainless steel conveyor belt, with continuous tensioning
- Electronic control panel on front left side
- Double Peephole for checking the burner status
- Baking chamber in stainless steel sheets
- Top and bottom blowers in welded stainless steel sheets, extractable for cleaning
- Double Low-emission (NOx, CO) stainless steel burner
- Double Combustion chamber entirely built with special high-temperatures stainless steel
- Rock wool heat insulation, thermal joints and air space COOL AROUND® Technology

ACCESSORIES

- Stand with castors, height 153, 600mm complete with pocket for screens
- Remote-Master® Technology
- Thick mesh for direct baking of low-moisture doughs or for grilling vegetables
- Fast tape adjustable from 45 seconds to 10 minutes

BAKING DIMENSIONS

Belt width L	810mm
Internal length	910mm
Total length P	2050mm
Total length P with pizza rest	2475mm
Tot. baking surface	0,74m ²

STANDARD EQUIPMENT

- Color multilanguage display TFT 5"
- 100 customisable programs
- ECO-STAND BY™ TECHNOLOGY Saving device with the possibility to stop the belt for break
- Discontinuous baking cycle STEP
- Start-Stop function to move tape to the set point is reached
- LOCK function
- Customized Hotkey with recurring control
- Auto test with display of error message
- USB input and wifi module for sw update
- Double independent maximum temperature and minimum blow pressure safety devices
- Stainless steel resting support (+475mm)
- SmartBaking app

TOP VIEW

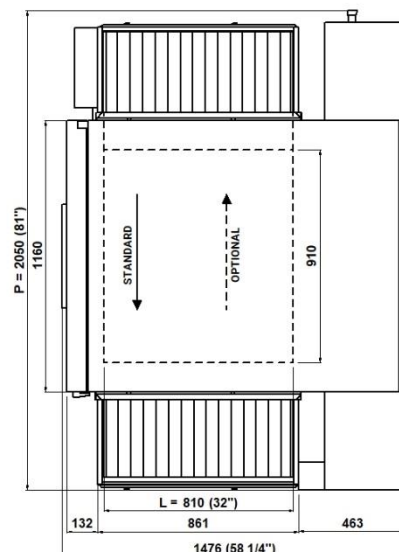

1 baking chamber
(assembled with stand height 600mm)

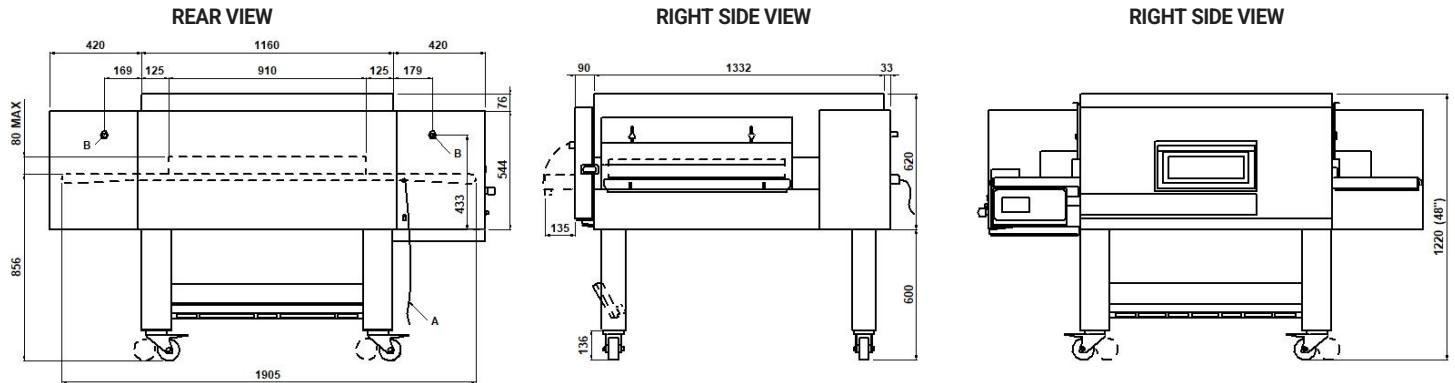

NOTE: The dimensions indicated in the views are in millimeters.

A Electrical cable length 2 meters	B Cone-shaped male gas manifold 3/4" GAS		
---	---	--	--

DIMENSIONS

External height	1220mm
External depth.	1476mm
External width.	2050mm
Weight (excl. stand)	365kg

TOTAL BAKING CAPACITY

*N° Pizzas /hour	
Pizzas diameter 330mm	N°125
Pizzas diameter 450mm	N°48

SHIPPING INFORMATION

Dimensions of packed oven	
Height	790mm
Depth	1725mm
Width	2152mm
Weight	(365+30)kg

Packaged stand dimensions:

Height	200mm
Depth	600mm
Width	1150mm
Weight	(28+2)kg

FEEDING AND POWER

Type of equipment	A3-B23
Thermic power max	30kW
Therm. power reduced	7,5kW
Gas power: NATURAL GAS or LPG	
*Hour consumption max	
Natural gas G20	3,174m ³ /h
Natural gas G25	3,69m ³ /h
Natural gas G25.1	3,686m ³ /h
Natural gas G25.3	3,61m ³ /h
LPG G30	2,366kg/h
LPG G31	2,331kg/h
Standard electric power	
A.C. V230 1N	
Frequency	50/60Hz
Electric power	0,7kW
Connecting cable for each chamber type:	
H07RN-F	3x1,5mm ²

* This value is subject to variation according to the way in which the equipment is used

NOTE: MORETTI FORNI S.P.A. reserves the right to modify the characteristics of the products illustrated in this publication without prior notice

2 baking chambers
(assembled with stand height 600mm)

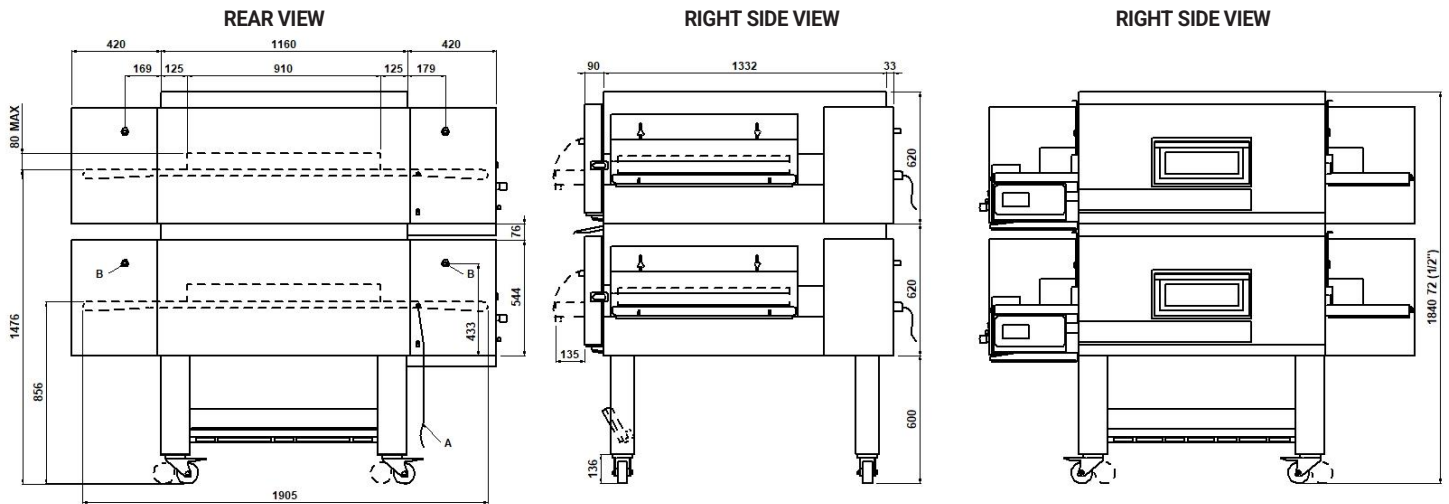

NOTE: The dimensions indicated in the views are in millimeters.

A Electrical cable length 2 meters	B Cone-shaped male gas manifold 3/4" GAS		
---	---	--	--

DIMENSIONS

External height	1840mm
External depth.	1476mm
External width.	2050mm
Weight (excl. stand)	730kg

TOTAL BAKING CAPACITY

*N° Pizzas /hour	
Pizzas diameter 330mm	N°250
Pizzas diameter 450mm	N°96

SHIPPING INFORMATION

Packed oven (each packed deck)	
Height	2x790mm
Depth	1725mm
Width	2152mm
Weight	(730+60)kg

Packaged stand dimensions:

Height	200mm
Depth	600mm
Width	1150mm
Weight	(28+2)kg

FEEDING AND POWER

Type of equipment	A3-B23
Thermic power max	60kW
Therm. power reduced	15kW
Gas power: NATURAL GAS or LPG	
*Hour consumption max	
Natural gas G20	6,348m ³ /h
Natural gas G25	7,38m ³ /h
Natural gas G25.1	7,372m ³ /h
Natural gas G25.3	7,22m ³ /h
LPG G30	4,732kg/h
LPG G31	4,662kg/h
Standard electric power	
A.C. V230 1N	
Frequency	50/60Hz
Electric power	1,4kW
Connecting cable for each chamber	
type:	
H07RN-F	3x1,5mm ²

* This value is subject to variation according to the way in which the equipment is used
NOTE: MORETTI FORNI S.P.A. reserves the right to modify the characteristics of the products illustrated in this publication without prior notice

3 baking chambers
(assembled with stand height 153mm)

REAR VIEW

RIGHT SIDE VIEW

RIGHT SIDE VIEW

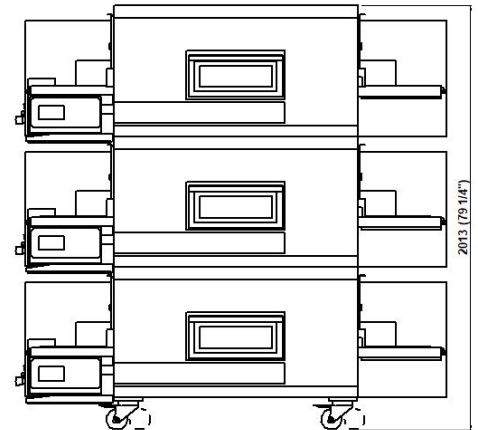
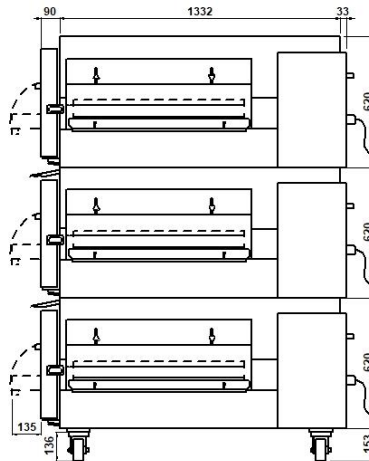
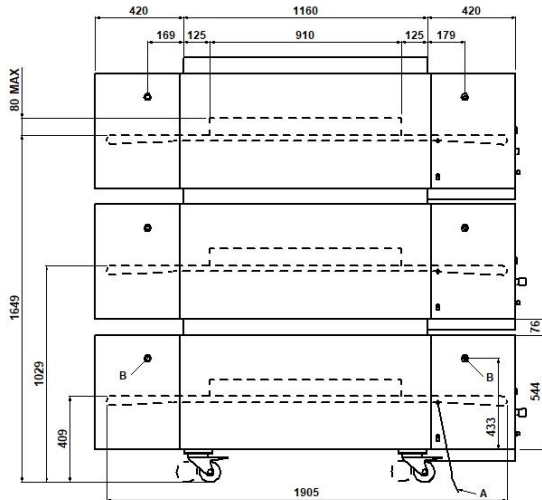

NOTE: The dimensions indicated in the views are in millimeters.

A

Electrical cable
length 2 meters

B

Cone-shaped male gas manifold
3/4" GAS

DIMENSIONS

External height	2013mm
External depth.	1476mm
External width.	2050mm
Weight (excl. stand)	1095kg

TOTAL BAKING CAPACITY

*N° Pizzas /hour	
Pizzas diameter 330mm	N°375
Pizzas diameter 450mm	N°144

SHIPPING INFORMATION

Packed oven (each packed deck)	3x790mm
Height	1725mm
Depth	2152mm
Width	(1095+90)kg
Weight	

Packaged stand dimensions:

Height	280mm
Depth	420mm
Width	270mm
Weight	(16+1)kg

FEEDING AND POWER

Type of equipment	A3-B23
Thermic power max	90kW
Therm. power reduced	22,5kW
Gas power: NATURAL GAS or LPG	
*Hour consumption max	
Natural gas G20	9,522m ³ /h
Natural gas G25	11,07m ³ /h
Natural gas G25.1	11,058m ³ /h
Natural gas G25.3	10,83m ³ /h
LPG G30	7,098kg/h
LPG G31	6,993kg/h
Standard electric power	
A.C. V230 1N	
Frequency	50/60Hz
Electric power	2,1kW
Connecting cable for each chamber type:	
H07RN-F	3x1,5mm ²

* This value is subject to variation according to the way in which the equipment is used

NOTE: MORETTI FORNI S.P.A. reserves the right to modify the characteristics of the products illustrated in this publication without prior notice