



## Modular electric deck oven 2 decks composition

**serieX** is the first oven in the market equipped with **Any Chef™ Technology**, able to autonomously set the **perfect baking cycle for any kind of product**.

Ideal for **Any Business**, serieX grants a substantial saving in h/operator costs. Specific for **Any Product**, can fit **in Any Place**, thanks to energy consumption reduced by 45%.

The **intuitive interface** makes serieX suitable for **Any Chef**: everyone can be a baking master of **pizza, bread, pastry and gastronomy**. By choosing your recipe parameters, serieX will automatically set the temperature and baking time, and the user-friendly **TFT Touch display will show the best area to place the product**.

serieX takes the oven to another level: not only a tool, but also a **precious partner to which delegate part of your daily work**.



### OPERATION

- Heated by highly performing armoured heating elements, working independently in each baking area
- SmartDeck™: thanks to the sensor system in each baking area, the heat is supplied only where needed, automatically regulating the heating elements power according to product type and quantity. The display always suggests the best area to use, allowing the right surface rotation and utilising heat at its best. The system determines the workload and automatically sets Auto EcoStandby™ for pauses or Auto PowerBooster™ for work peaks
- Adaptive BakingTime™ thanks to the software algorithm, the baking time adapts depending both on the heat quantity detected and on the product in the baking area
- Pre-set cycles with variable phases specific for bread, pastry and gastronomy products
- UI with intuitive sliders that allow to easily customise the baking result. Mapping is optimised for every product
- AdaptivePower® Technology: power management with P.I.D. permits automatic energy regulation based on the quantity of product baked
- DualPower+™: ceiling / floor temperature and power can be managed separately and simultaneously
- Continuous temperature detection inside the baking chamber through 2 thermocouples
- Optimal heat balancing since the first baking
- Automatic pyrolytic cleaning program, PowerCleaning™
- Self-limited temperature at 400°C
- Vapour discharge by programmable steam valve

### CONSTRUCTION

- Front structure made of bent stainless steel with Steel-X finishing inserts
- Side panels in painted metal sheet
- Channel hood
- Separable doors with total or partial opening available in every moment
- Stainless steel door with external fairing for better insulation and safety
- Brushed stainless steel handles made with antiseptic finish
- Refractory brick baking surface
- Side and top internal structure made of aluminised steel
- Internal rear-view mirrors made of reflecting steel suitable for high temperatures (not applied for decks equipped with steamer)
- Oriented double LED light, placed in a protected position
- Heat insulation CoolAround® Technology

### INTERNAL BAKING CHAMBER DIMENSIONS

|                 |                   |
|-----------------|-------------------|
| Internal height | 160mm             |
| Internal depth  | 735mm             |
| Internal width  | 950mm             |
| Baking surface  | 0,7m <sup>2</sup> |

### ACCESSORIES

- Prover with wheels height 600, 800mm
- Stand with wheels height 400, 600, 800, 950, 1050mm
- Programmable steamer with steam regulation
- Additional tray holder guides for prover and stand
- Soundproof motor for hood 500 m3/h
- Front hood spacer element 40mm high
- Frontless hood H=175 mm
- Door opening upwards
- Multipoint core probe
- Self-condensing hood
- Remote-Master® Technology

### STANDARD EQUIPMENT

- Multilanguage, antiglare, colour display TFT Touch 7" IPS
- Customisable baking cycles according to your dough
- 4 different working modes: Bake, Regenerate, Prebake, Refining®
- Auto EcoStandby™ for work pauses
- Auto PowerBooster™ for work peaks
- Oven front/rear and right/left power balance DeltaPower+™
- ReadyToGo Timer, optimised switch on based on baking time set. Two daily start and stop programmable.
- FlexLoad™ automatically identifies where the work load is activating the heating elements in the corresponding area
- Self-diagnosis with error message on display
- Multi timer
- Maximum temperature independent safety device
- USB port and WiFi module for software update
- SmartBaking app

### TOP VIEW

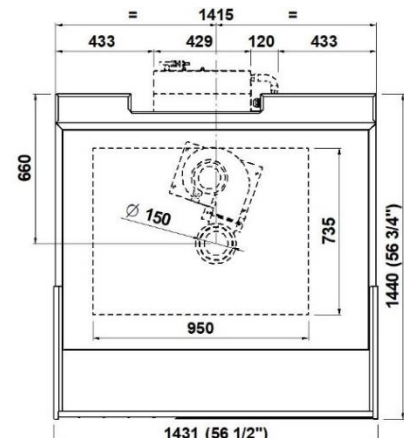

**1 baking chamber height 16cm**  
(assembled with stand height 950mm)

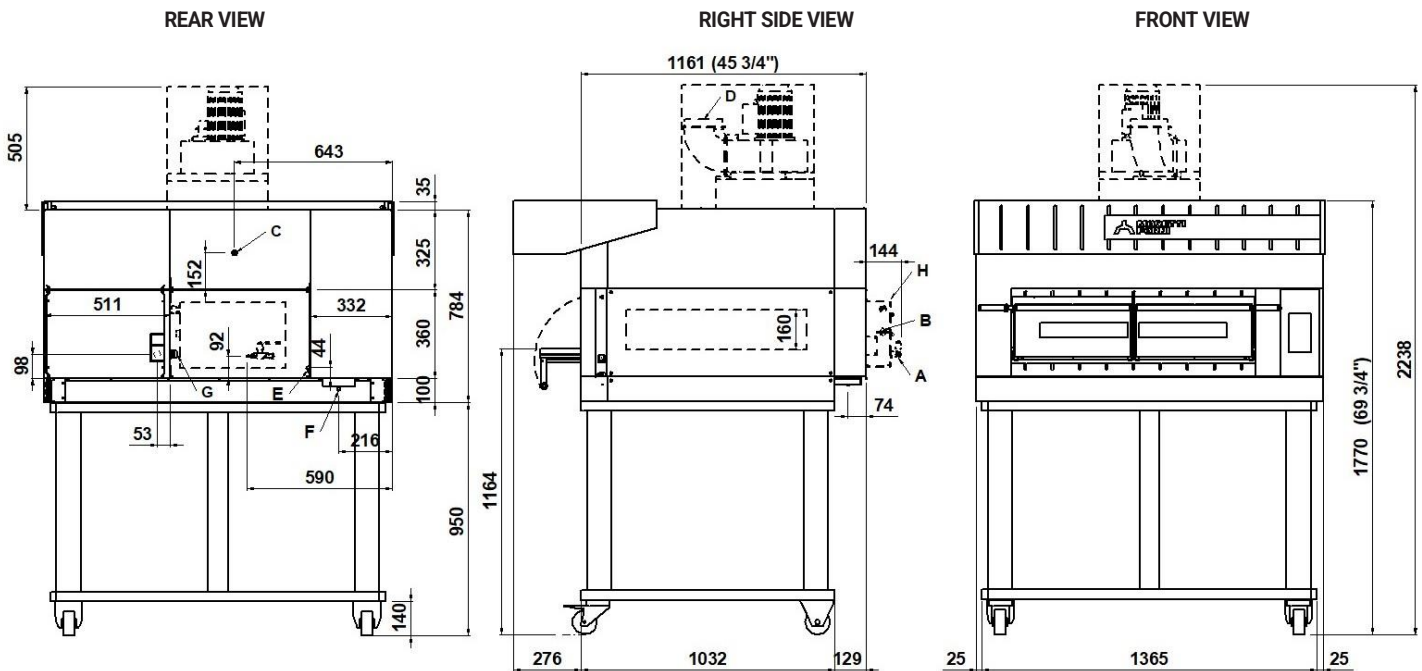

**NOTE:** The dimensions indicated in the views are in millimetres.

|  |  |  |   |
|--|--|--|---|
| <b>A</b><br>ø8<br>steamer water outlet | <b>B</b><br>3/4" male<br>steamer water inlet | <b>C</b><br>Ø16<br>hood condensation exhaust | <b>D</b><br>Ø150<br>steam exhaust             |
| <b>E</b><br>M6<br>equipotential screws | <b>F</b><br>Ø12<br>condensation exhaust      | <b>G</b><br>fairleads                        | <b>H</b><br>Steamer 1600W<br>(see data sheet) |

**DIMENSIONS**

|                 |        |
|-----------------|--------|
| External height | 820mm  |
| External depth  | 1161mm |
| External width  | 1431mm |
| Weight          | 278kg  |

**TOTAL BAKING CAPACITY**

|                      |   |
|----------------------|---|
| Tray (600x400mm)     | 2 |
| Pizza diameter 350mm | 4 |
| Pizza diameter 450mm | 2 |

**SHIPPING INFORMATION**

|                                     |            |
|-------------------------------------|------------|
| Packed in wooden crate              |            |
| Height                              | 1020mm     |
| Depth                               | 1640mm     |
| Width                               | 1640mm     |
| Weight                              | (278+50)kg |
| When combined with stand or prover: |            |
| Max height                          | 1970mm     |
| Max weight                          | (389+60)kg |

**FEEDING AND POWER**

|                                   |                      |
|-----------------------------------|----------------------|
| Standard feeding                  |                      |
| A.C. V400 3N                      |                      |
| Feeding on request                |                      |
| A.C. V230 3                       |                      |
| Frequency                         | 50/60Hz              |
| Max power                         | 8,8kW                |
| *Average power cons.              | 2,4÷3,2kWh           |
| Connecting cable for each chamber |                      |
| type H07RN-F                      |                      |
| 5x4mm <sup>2</sup> (V400 3N)      |                      |
| 4x6mm <sup>2</sup> (V230 3)       |                      |
| Power supply (optional prover)    |                      |
| A.C. V230 1N 50/60 Hz             |                      |
| Max power                         | 1,5kW                |
| *Average power cons.              | 0,8kWh               |
| Conn. Cable type H07RN-F          | 3x1,5mm <sup>2</sup> |

\* This value is subject to variation according to the way in which the equipment is used

**NOTE:** MORETTI FORNI S.P.A. reserves the right to modify the characteristics of the products illustrated in this publication without prior notice

**2 baking chambers height 16cm**  
(assembled with prover height 800mm)

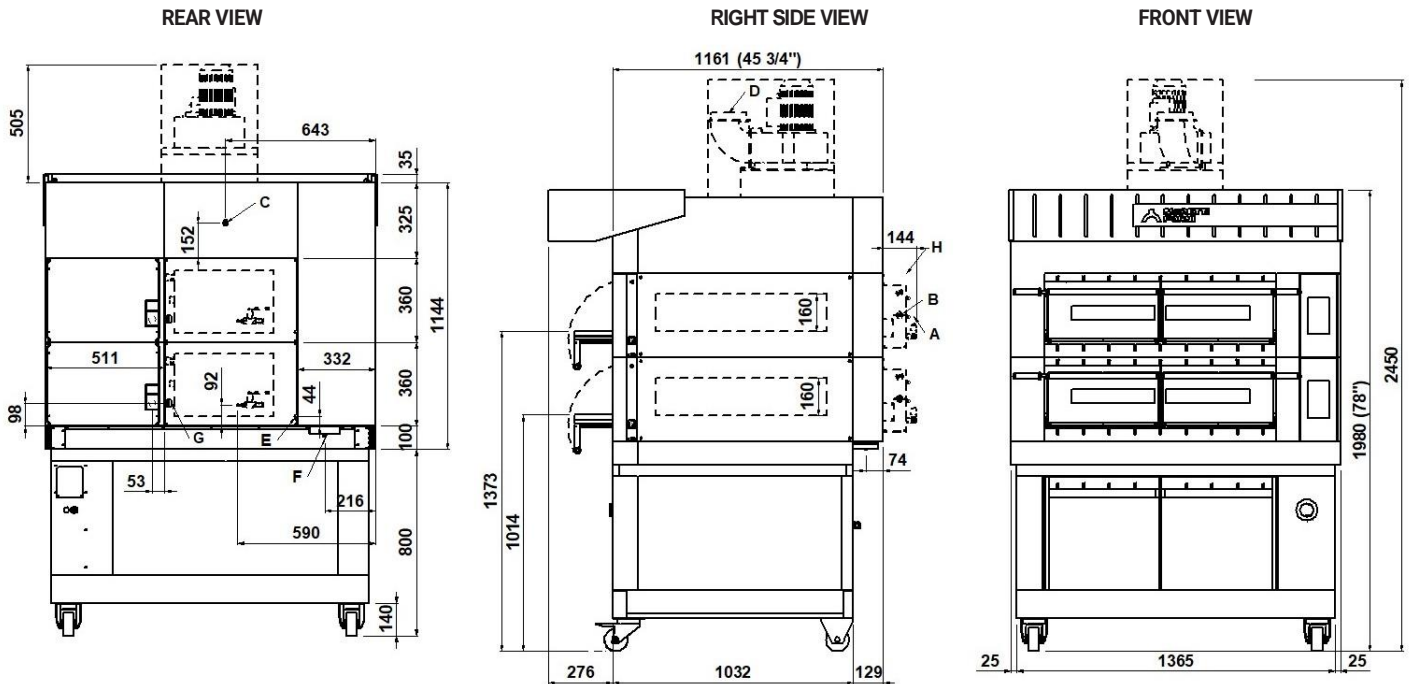

NOTE: The dimensions indicated in the views are in millimetres.

|  |  |  |   |
|--|--|--|---|
| <b>A</b><br>ø8<br>steamer water outlet | <b>B</b><br>3/4" male<br>steamer water inlet | <b>C</b><br>Ø16<br>hood condensation exhaust | <b>D</b><br>Ø150<br>steam exhaust             |
| <b>E</b><br>M6<br>equipotential screws | <b>F</b><br>Ø12<br>condensation exhaust      | <b>G</b><br>fairleads                        | <b>H</b><br>steamer 1600W<br>(see data sheet) |

**DIMENSIONS**

|                 |        |
|-----------------|--------|
| External height | 1180mm |
| External depth  | 1161mm |
| External width  | 1431mm |
| Weight          | 451kg  |

**TOTAL BAKING CAPACITY**

|                      |   |
|----------------------|---|
| Tray (600x400 mm)    | 4 |
| Pizza diameter 350mm | 8 |
| Pizza diameter 450mm | 4 |

**SHIPPING INFORMATION**

|                        |            |
|------------------------|------------|
| Packed in wooden crate |            |
| Height                 | 1380mm     |
| Depth                  | 1640mm     |
| Width                  | 1640mm     |
| Weight                 | (451+60)kg |

|                                     |            |
|-------------------------------------|------------|
| When combined with stand or prover: |            |
| Max height                          | 2200mm     |
| Max weight                          | (562+70)kg |

**FEEDING AND POWER**

|                                   |                      |
|-----------------------------------|----------------------|
| Standard feeding                  |                      |
| A.C. V400 3N                      |                      |
| Feeding on request                |                      |
| A.C. V230 3                       |                      |
| Frequency                         | 50/60Hz              |
| Max power                         | 17,6kW               |
| *Average power cons               | 4,8÷6,4kWh           |
| Connecting cable for each chamber |                      |
| type H07RN-F                      |                      |
| 5x4mm <sup>2</sup> (V400 3N)      |                      |
| 4x6mm <sup>2</sup> (V230 3)       |                      |
| Power supply (optional prover)    |                      |
| A.C. V230 1N 50/60 Hz             |                      |
| Max power                         | 1,5kW                |
| *Average power cons               | 0,8kWh               |
| Conn. Cable type H07RN-F          | 3x1,5mm <sup>2</sup> |

\* This value is subject to variation according to the way in which the equipment is used  
NOTE: MORETTI FORNI S.P.A. reserves the right to modify the characteristics of the products illustrated in this publication without prior notice

**3 baking chambers height 16 cm**  
(assembled with prover height 600mm)

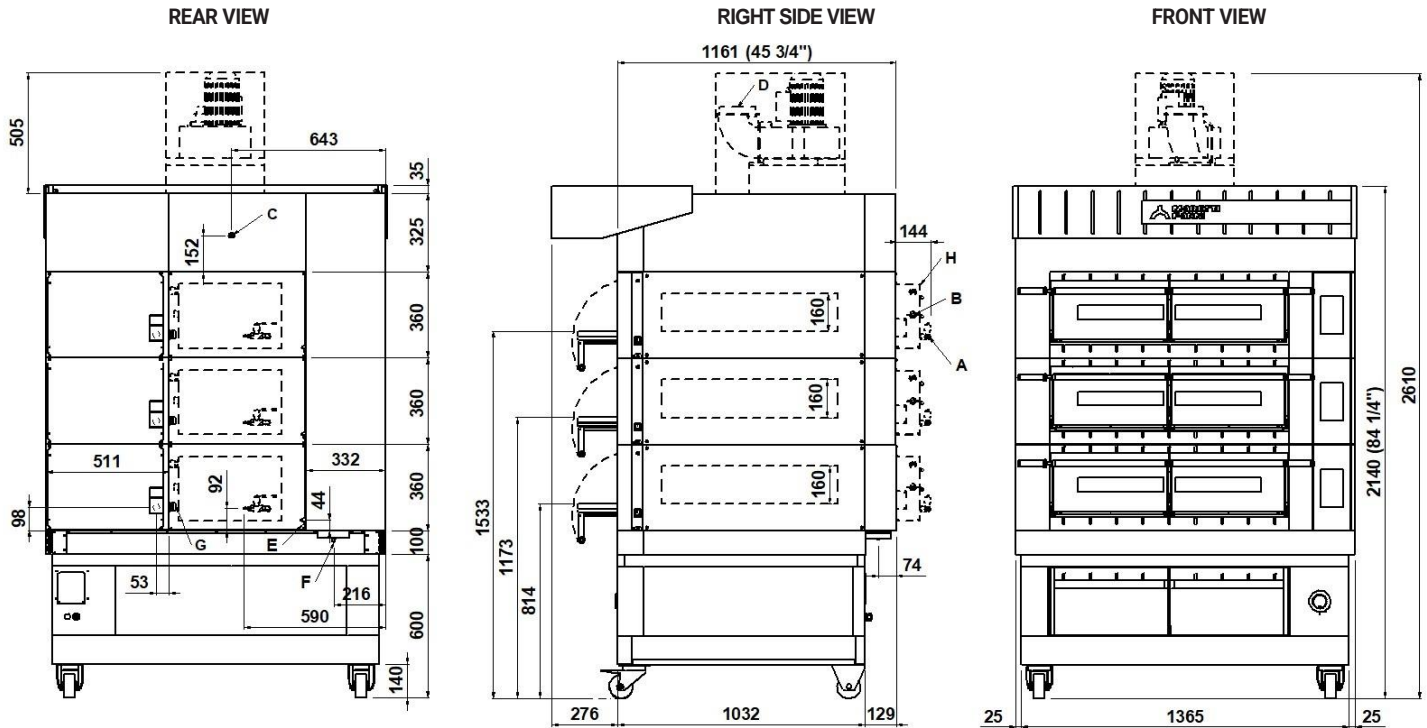

**NOTE:** The dimensions indicated in the views are in millimetres. \*Dimensions refer to the oversized hood.

|  |  |  |   |
|--|--|--|---|
| <b>A</b><br>ø8<br>steamer water outlet | <b>B</b><br>3/4" male<br>steamer water inlet | <b>C</b><br>Ø16<br>hood condensation exhaust | <b>D</b><br>Ø150<br>steam exhaust             |
| <b>E</b><br>M6<br>equipotential screws | <b>F</b><br>Ø12<br>condensation exhaust      | <b>G</b><br>fairleads                        | <b>H</b><br>steamer 1600W<br>(see data sheet) |

**DIMENSIONS**

|                 |        |
|-----------------|--------|
| External height | 1540mm |
| External depth  | 1161mm |
| External width  | 1431mm |
| Weight          | 623kg  |

**SHIPPING INFORMATION**

|                        |            |
|------------------------|------------|
| Packed in wooden crate | 1740mm     |
| Height                 | 1640mm     |
| Depth                  | 1640mm     |
| Width                  | 1640mm     |
| Weight                 | (623+70)kg |

**FEEDING AND POWER**

|                                   |                              |
|-----------------------------------|------------------------------|
| Standard feeding                  | A.C. V400 3N                 |
| Feeding on request                | A.C. V230 3                  |
| Frequency                         | 50/60Hz                      |
| Max power                         | 26,4kW                       |
| *Average power cons               | 7,2÷9,6kWh                   |
| Connecting cable for each chamber | type H07RN-F                 |
|                                   | 5x4mm <sup>2</sup> (V400 3N) |
|                                   | 4x6mm <sup>2</sup> (V230 3)  |
| Power supply (optional prover)    | A.C. V230 1N 50/60 Hz        |
| Max power                         | 1,5kW                        |
| *Average power cons               | 0,8kWh                       |
| Conn. Cable type                  | H07RN-F 3x1,5mm <sup>2</sup> |

**TOTAL BAKING CAPACITY**

|                      |    |
|----------------------|----|
| Tray (600x400 mm)    | 6  |
| Pizza diameter 350mm | 12 |
| Pizza diameter 450mm | 6  |

|                                     |            |
|-------------------------------------|------------|
| When combined with stand or prover: |            |
| Max height                          | 2350mm     |
| Max weight                          | (710+80)kg |

\* This value is subject to variation according to the way in which the equipment is used

**NOTE:** MORETTI FORNI S.P.A. reserves the right to modify the characteristics of the products illustrated in this publication without prior notice

**2 baking chambers height 16+22 cm**  
(assembled with prover height 800mm)

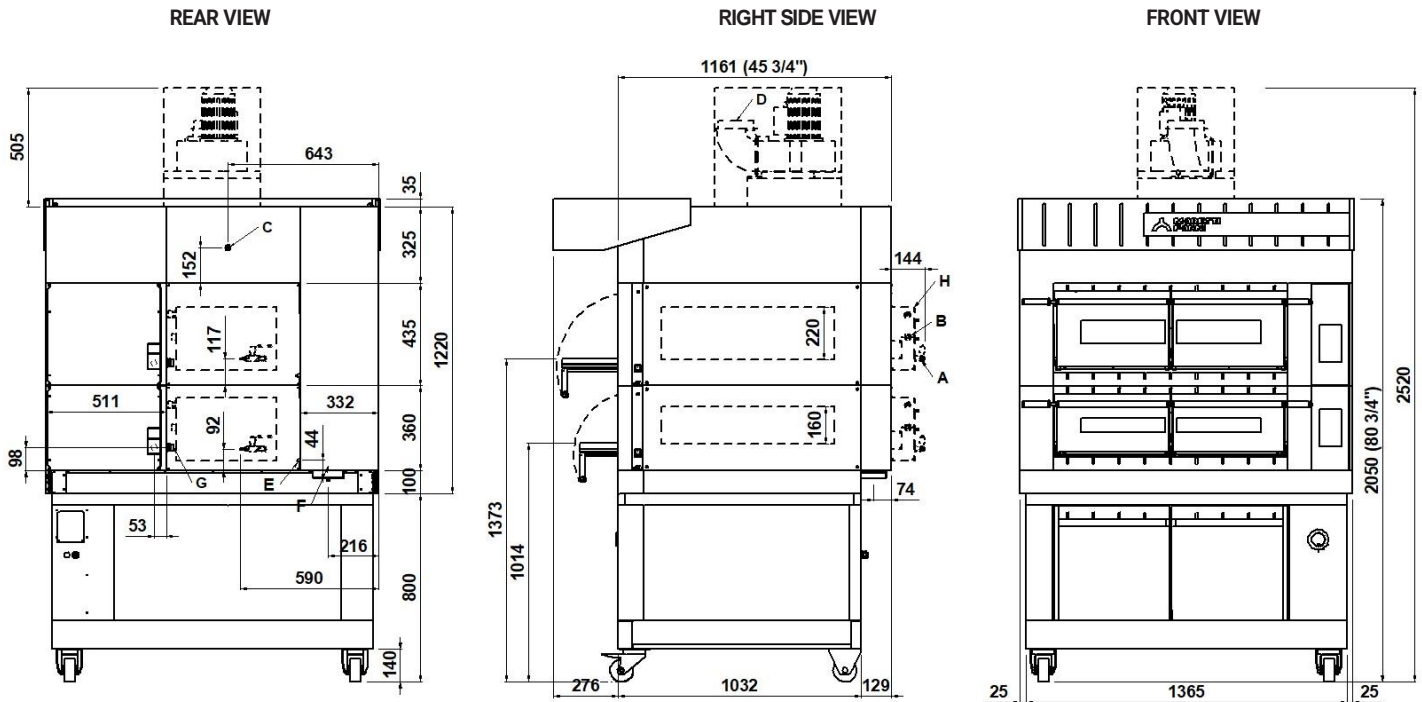

**NOTE:** The dimensions indicated in the views are in millimetres.

|  |  |  |   |
|--|--|--|---|
| <b>A</b><br>ø8<br>steamer water outlet | <b>B</b><br>3/4" male<br>steamer water inlet | <b>C</b><br>Ø16<br>hood condensation exhaust | <b>D</b><br>Ø150<br>steam exhaust             |
| <b>E</b><br>M6<br>equipotential screws | <b>F</b><br>Ø12<br>condensation exhaust      | <b>G</b><br>fairleads                        | <b>H</b><br>steamer 1600W<br>(see data sheet) |

**DIMENSIONI ESTERNE**

|                 |        |
|-----------------|--------|
| External height | 1255mm |
| External depth  | 1161mm |
| External width  | 1431mm |
| Weight          | 461kg  |

**TOTAL BAKING CAPACITY**

|                      |   |
|----------------------|---|
| Tray (600x400 mm)    | 4 |
| Pizza diameter 350mm | 8 |
| Pizza diameter 450mm | 4 |

**SHIPPING INFORMATION**

|                        |            |
|------------------------|------------|
| Packed in wooden crate |            |
| Height                 | 1455mm     |
| Depth                  | 1640mm     |
| Width                  | 1640mm     |
| Weight                 | (461+60)kg |

|                                     |            |
|-------------------------------------|------------|
| When combined with stand or prover: |            |
| Max height                          | 2255mm     |
| Max weight                          | (572+70)kg |

**FEEDING AND POWER**

|                                   |                      |
|-----------------------------------|----------------------|
| Standard feeding                  |                      |
| A.C. V400 3N                      |                      |
| Feeding on request                |                      |
| A.C. V230 3                       |                      |
| Frequency                         | 50/60Hz              |
| Max power                         | 17,6kW               |
| *Average power cons               | 4,8÷6,4kWh           |
| Connecting cable for each chamber |                      |
| type H07RN-F                      |                      |
| 5x4mm <sup>2</sup> (V400 3N)      |                      |
| 4x6mm <sup>2</sup> (V230 3)       |                      |
| Power supply (optional prover)    |                      |
| A.C. V230 1N 50/60 Hz             |                      |
| Max power                         | 1,5kW                |
| *Average power cons               | 0,8kWh               |
| Conn. Cable type H07RN-F          | 3x1,5mm <sup>2</sup> |

\* This value is subject to variation according to the way in which the equipment is used  
NOTE: MORETTI FORNI S.P.A. reserves the right to modify the characteristics of the products illustrated in this publication without prior notice

**3 baking chambers height 16+16+22 cm**  
(assembled with prover height 600mm)

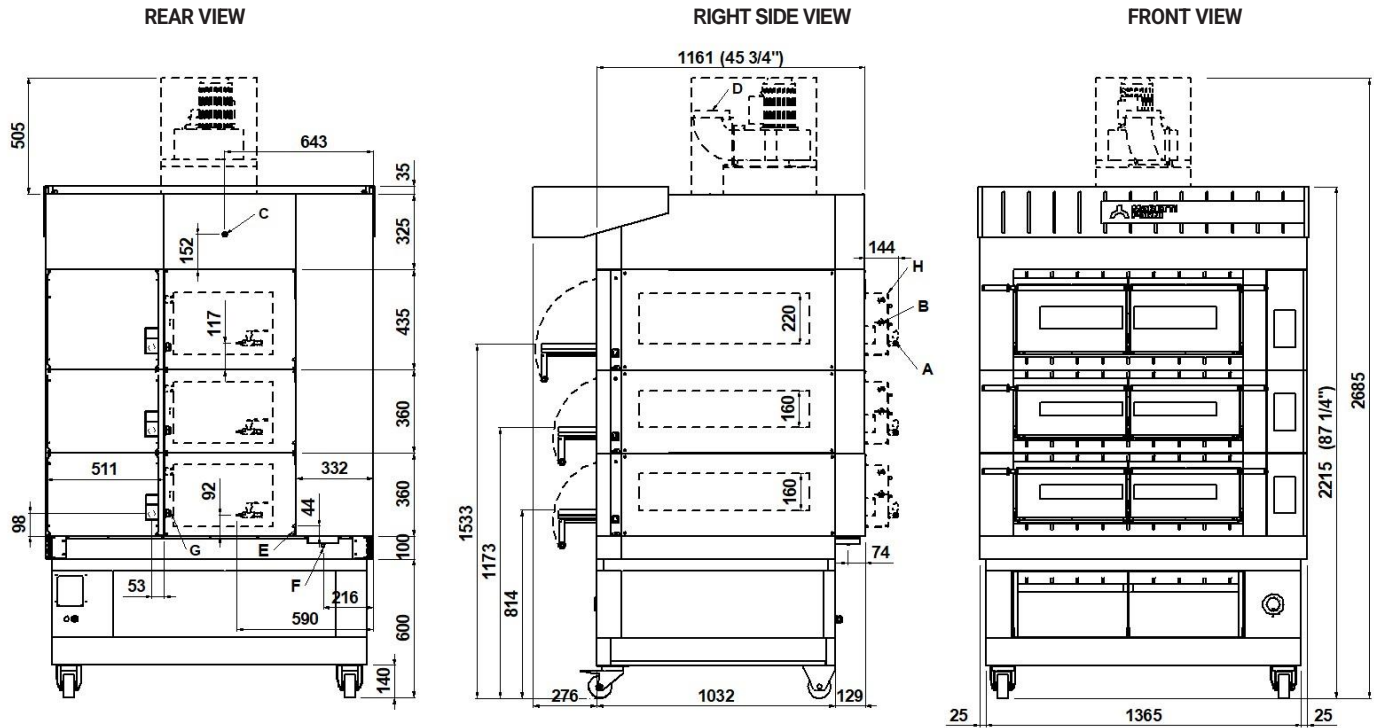

**NOTE:** The dimensions indicated in the views are in millimetres. \*Dimensions refer to the oversized hood.

|  |  |  |   |
|--|--|--|---|
| <b>A</b><br>ø8<br>steamer water outlet | <b>B</b><br>3/4" male<br>steamer water inlet | <b>C</b><br>Ø16<br>hood condensation exhaust | <b>D</b><br>Ø150<br>steam exhaust             |
| <b>E</b><br>M6<br>equipotential screws | <b>F</b><br>Ø12<br>condensation exhaust      | <b>G</b><br>fairleads                        | <b>H</b><br>steamer 1600W<br>(see data sheet) |

**DIMENSIONS**

|                 |        |
|-----------------|--------|
| External height | 1615mm |
| External depth  | 1161mm |
| External width  | 1431mm |
| Weight          | 634kg  |

**SHIPPING INFORMATION**

|                        |            |
|------------------------|------------|
| Packed in wooden crate | 1815mm     |
| Height                 | 1640mm     |
| Depth                  | 1640mm     |
| Width                  | (634+70)kg |
| Weight                 |            |

**FEEDING AND POWER**

|   |            |
|---|------------|
| Standard feeding                              |            |
| A.C. V400 3N                                  |            |
| Feeding on request                            |            |
| A.C. V230 3                                   |            |
| Frequency                                     | 50/60Hz    |
| Max power                                     | 26,4kW     |
| *Average power cons                           | 7,2÷9,6kWh |
| Connecting cable for each chamber             |            |
| type H07RN-F                                  |            |
| 5x4mm <sup>2</sup> (V400 3N)                  |            |
| 4x6mm <sup>2</sup> (V230 3)                   |            |
| Power supply (optional prover)                |            |
| A.C. V230 1N 50/60 Hz                         |            |
| Max power                                     | 1,5kW      |
| *Average power cons                           | 0,8kWh     |
| Conn. Cable type H07RN-F 3x1,5mm <sup>2</sup> |            |

**TOTAL BAKING CAPACITY**

|                      |    |
|----------------------|----|
| Tray (600x400 mm)    | 6  |
| Pizza diameter 350mm | 12 |
| Pizza diameter 450mm | 6  |

|                                     |            |
|-------------------------------------|------------|
| When combined with stand or prover: |            |
| Max height                          | 2415mm     |
| Max weight                          | (721+80)kg |

\* This value is subject to variation according to the way in which the equipment is used

**NOTE:** MORETTI FORNI S.P.A. reserves the right to modify the characteristics of the products illustrated in this publication without prior notice

**X100**  
TECHNICAL DATA

| <b>SHIPPING INFORMATION H16</b>    |              | <b>X100E_1_16</b> | <b>X100E_2_16</b> | <b>X100E_3_16</b> |
|------------------------------------|--------------|-------------------|-------------------|-------------------|
| Packed in wooden crate             | Height       | 1020mm            | 1380mm            | 1740mm            |
|                                    | Weight       | (278+50)kg        | (451+60)kg        | (623+70)kg        |
| When combined with prover or Stand | Max. height. | 1970mm            | 2200mm            | 2350mm            |
|                                    | Max. weight. | (389+60)kg        | (562+70)kg        | (710+80)kg        |
| <b>SHIPPING INFORMATION H22</b>    |              | <b>X510E_1_22</b> | <b>X100E_2_22</b> | <b>X100E_3_22</b> |
| Packed in wooden crate             | Height       | 1095mm            | 1530mm            | 1965mm            |
|                                    | Weight       | (289+50)kg        | (472+60)kg        | (655+70)kg        |
| When combined with prover or Stand | Max. height. | 2045mm            | 2330mm            | 2565mm            |
|                                    | Max. weight. | (400+60)kg        | (583+70)kg        | (742+80)kg        |

\* This value is subject to variation according to the way in which the equipment is used  
NOTE: MORETTI FORNI S.P.A. reserves the right to modify the characteristics of the products illustrated in this publication without prior notice



## Modular electric deck oven 2 decks composition

**serieX** is the first oven in the market equipped with **Any Chef™ Technology**, able to autonomously set the **perfect baking cycle for any kind of product**.

Ideal for **Any Business**, serieX grants a substantial saving in h/operator costs. Specific for **Any Product**, can fit **in Any Place**, thanks to energy consumption reduced by 45%.

The **intuitive interface** makes serieX suitable for **Any Chef**: everyone can be a baking master of **pizza, bread, pastry and gastronomy**. By choosing your recipe parameters, serieX will automatically set the temperature and baking time, and the user-friendly **TFT Touch display will show the best area to place the product**.

serieX takes the oven to another level: not only a tool, but also a **precious partner to which delegate part of your daily work**.



### OPERATION

- Heated by highly performing armoured heating elements, working independently in each baking area
- SmartDeck™: thanks to the sensor system in each baking area, the heat is supplied only where needed, automatically regulating the heating elements power according to product type and quantity. The display always suggests the best area to use, allowing the right surface rotation and utilising heat at its best. The system determines the workload and automatically sets Auto EcoStandby™ for pauses or Auto PowerBooster™ for work peaks
- Adaptive BakingTime™ thanks to the software algorithm, the baking time adapts depending both on the heat quantity detected and on the product in the baking area
- Pre-set cycles with variable phases specific for bread, pastry and gastronomy products
- UI with intuitive sliders that allow to easily customise the baking result. Mapping is optimised for every product
- AdaptivePower® Technology: power management with P.I.D. permits automatic energy regulation based on the quantity of product baked
- DualPower+™: ceiling / floor temperature and power can be managed separately and simultaneously
- Continuous temperature detection inside the baking chamber through 2 thermocouples
- Optimal heat balancing since the first baking
- Automatic pyrolytic cleaning program, PowerCleaning™
- Self-limited temperature at 400°C
- Vapour discharge by programmable steam valve

### CONSTRUCTION

- Front structure made of bent stainless steel with Steel-X finishing inserts
- Side panels in painted metal sheet
- Channel hood
- Separable doors with total or partial opening available in every moment
- Stainless steel door with external fairing for better insulation and safety
- Brushed stainless steel handles made with antiseptic finish
- Refractory brick baking surface
- Side and top internal structure made of aluminised steel
- Internal rear-view mirrors made of reflecting steel suitable for high temperatures (not applied for decks equipped with steamer)
- Oriented double LED light, placed in a protected position
- Heat insulation CoolAround® Technology

### INTERNAL BAKING CHAMBER DIMENSIONS

|                 |                   |
|-----------------|-------------------|
| Internal height | 160mm             |
| Internal depth  | 735mm             |
| Internal width  | 950mm             |
| Baking surface  | 0,7m <sup>2</sup> |

### ACCESSORIES

- Prover with wheels height 600, 800mm
- Stand with wheels height 400, 600, 800, 950, 1050mm
- Programmable steamer with steam regulation
- Additional tray holder guides for prover and stand
- Soundproof motor for hood 500 m3/h
- Front hood spacer element 40mm high
- Frontless hood H=175 mm
- Door opening upwards
- Multipoint core probe
- Self-condensing hood
- Remote-Master® Technology

### STANDARD EQUIPMENT

- Multilanguage, antiglare, colour display TFT Touch 7" IPS
- Customisable baking cycles according to your dough
- 4 different working modes: Bake, Regenerate, Prebake, Refining®
- Auto EcoStandby™ for work pauses
- Auto PowerBooster™ for work peaks
- Oven front/rear and right/left power balance DeltaPower+™
- ReadyToGo Timer, optimised switch on based on baking time set. Two daily start and stop programmable.
- FlexLoad™ automatically identifies where the work load is activating the heating elements in the corresponding area
- Self-diagnosis with error message on display
- Multi timer
- Maximum temperature independent safety device
- USB port and WiFi module for software update
- SmartBaking app

### TOP VIEW

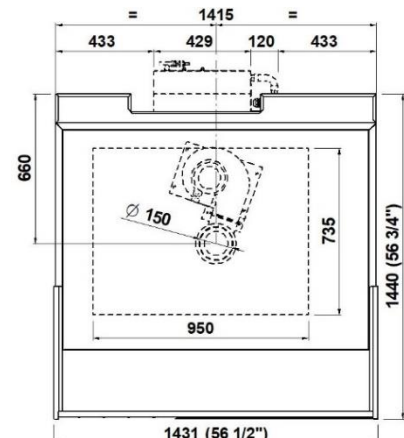

**1 baking chamber height 16cm**  
(assembled with stand height 950mm)

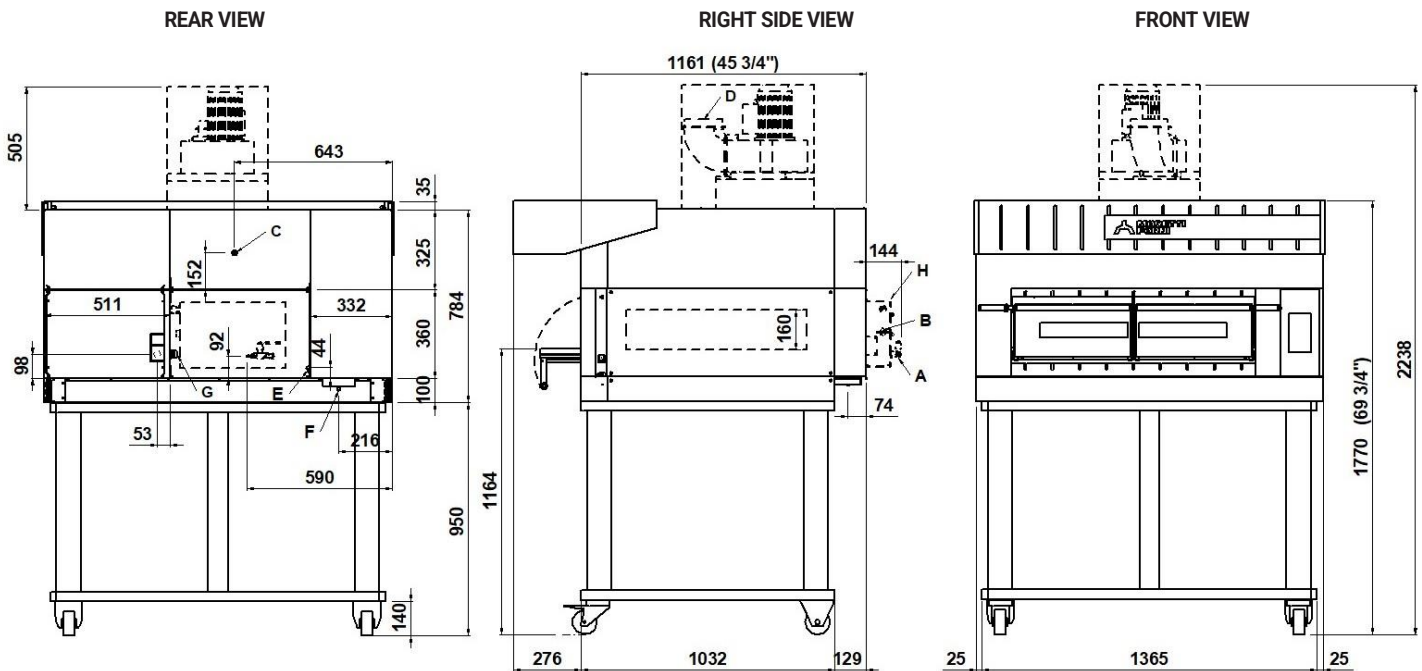

**NOTE:** The dimensions indicated in the views are in millimetres.

|  |  |  |   |
|--|--|--|---|
| <b>A</b><br>ø8<br>steamer water outlet | <b>B</b><br>3/4" male<br>steamer water inlet | <b>C</b><br>Ø16<br>hood condensation exhaust | <b>D</b><br>Ø150<br>steam exhaust             |
| <b>E</b><br>M6<br>equipotential screws | <b>F</b><br>Ø12<br>condensation exhaust      | <b>G</b><br>fairleads                        | <b>H</b><br>Steamer 1600W<br>(see data sheet) |

**DIMENSIONS**

|                 |        |
|-----------------|--------|
| External height | 820mm  |
| External depth  | 1161mm |
| External width  | 1431mm |
| Weight          | 278kg  |

**TOTAL BAKING CAPACITY**

|                      |   |
|----------------------|---|
| Tray (600x400mm)     | 2 |
| Pizza diameter 350mm | 4 |
| Pizza diameter 450mm | 2 |

**SHIPPING INFORMATION**

|                                     |            |
|-------------------------------------|------------|
| Packed in wooden crate              |            |
| Height                              | 1020mm     |
| Depth                               | 1640mm     |
| Width                               | 1640mm     |
| Weight                              | (278+50)kg |
| When combined with stand or prover: |            |
| Max height                          | 1970mm     |
| Max weight                          | (389+60)kg |

**FEEDING AND POWER**

|                                   |                      |
|-----------------------------------|----------------------|
| Standard feeding                  |                      |
| A.C. V400 3N                      |                      |
| Feeding on request                |                      |
| A.C. V230 3                       |                      |
| Frequency                         | 50/60Hz              |
| Max power                         | 8,8kW                |
| *Average power cons.              | 2,4÷3,2kWh           |
| Connecting cable for each chamber |                      |
| type H07RN-F                      |                      |
| 5x4mm <sup>2</sup> (V400 3N)      |                      |
| 4x6mm <sup>2</sup> (V230 3)       |                      |
| Power supply (optional prover)    |                      |
| A.C. V230 1N 50/60 Hz             |                      |
| Max power                         | 1,5kW                |
| *Average power cons.              | 0,8kWh               |
| Conn. Cable type H07RN-F          | 3x1,5mm <sup>2</sup> |

\* This value is subject to variation according to the way in which the equipment is used

**NOTE:** MORETTI FORNI S.P.A. reserves the right to modify the characteristics of the products illustrated in this publication without prior notice

**2 baking chambers height 16cm**  
(assembled with prover height 800mm)

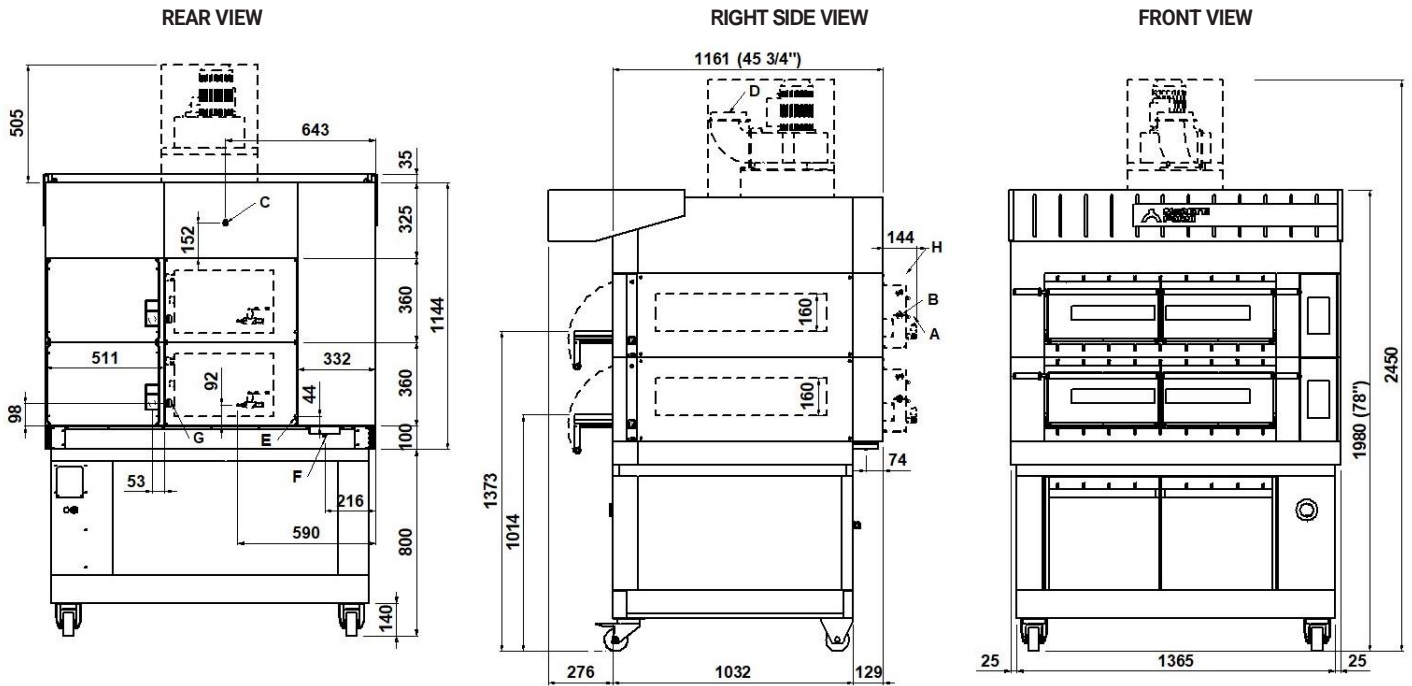

NOTE: The dimensions indicated in the views are in millimetres.

|  |  |  |   |
|--|--|--|---|
| <b>A</b><br>ø8<br>steamer water outlet | <b>B</b><br>3/4" male<br>steamer water inlet | <b>C</b><br>Ø16<br>hood condensation exhaust | <b>D</b><br>Ø150<br>steam exhaust             |
| <b>E</b><br>M6<br>equipotential screws | <b>F</b><br>Ø12<br>condensation exhaust      | <b>G</b><br>fairleads                        | <b>H</b><br>steamer 1600W<br>(see data sheet) |

**DIMENSIONS**

|                 |        |
|-----------------|--------|
| External height | 1180mm |
| External depth  | 1161mm |
| External width  | 1431mm |
| Weight          | 451kg  |

**TOTAL BAKING CAPACITY**

|                      |   |
|----------------------|---|
| Tray (600x400 mm)    | 4 |
| Pizza diameter 350mm | 8 |
| Pizza diameter 450mm | 4 |

**SHIPPING INFORMATION**

|                        |            |
|------------------------|------------|
| Packed in wooden crate |            |
| Height                 | 1380mm     |
| Depth                  | 1640mm     |
| Width                  | 1640mm     |
| Weight                 | (451+60)kg |

|                                     |            |
|-------------------------------------|------------|
| When combined with stand or prover: |            |
| Max height                          | 2200mm     |
| Max weight                          | (562+70)kg |

**FEEDING AND POWER**

|                                   |                      |
|-----------------------------------|----------------------|
| Standard feeding                  |                      |
| A.C. V400 3N                      |                      |
| Feeding on request                |                      |
| A.C. V230 3                       |                      |
| Frequency                         | 50/60Hz              |
| Max power                         | 17,6kW               |
| *Average power cons               | 4,8÷6,4kWh           |
| Connecting cable for each chamber |                      |
| type H07RN-F                      |                      |
| 5x4mm <sup>2</sup> (V400 3N)      |                      |
| 4x6mm <sup>2</sup> (V230 3)       |                      |
| Power supply (optional prover)    |                      |
| A.C. V230 1N 50/60 Hz             |                      |
| Max power                         | 1,5kW                |
| *Average power cons               | 0,8kWh               |
| Conn. Cable type H07RN-F          | 3x1,5mm <sup>2</sup> |

\* This value is subject to variation according to the way in which the equipment is used  
NOTE: MORETTI FORNI S.P.A. reserves the right to modify the characteristics of the products illustrated in this publication without prior notice

**3 baking chambers height 16 cm**  
(assembled with prover height 600mm)

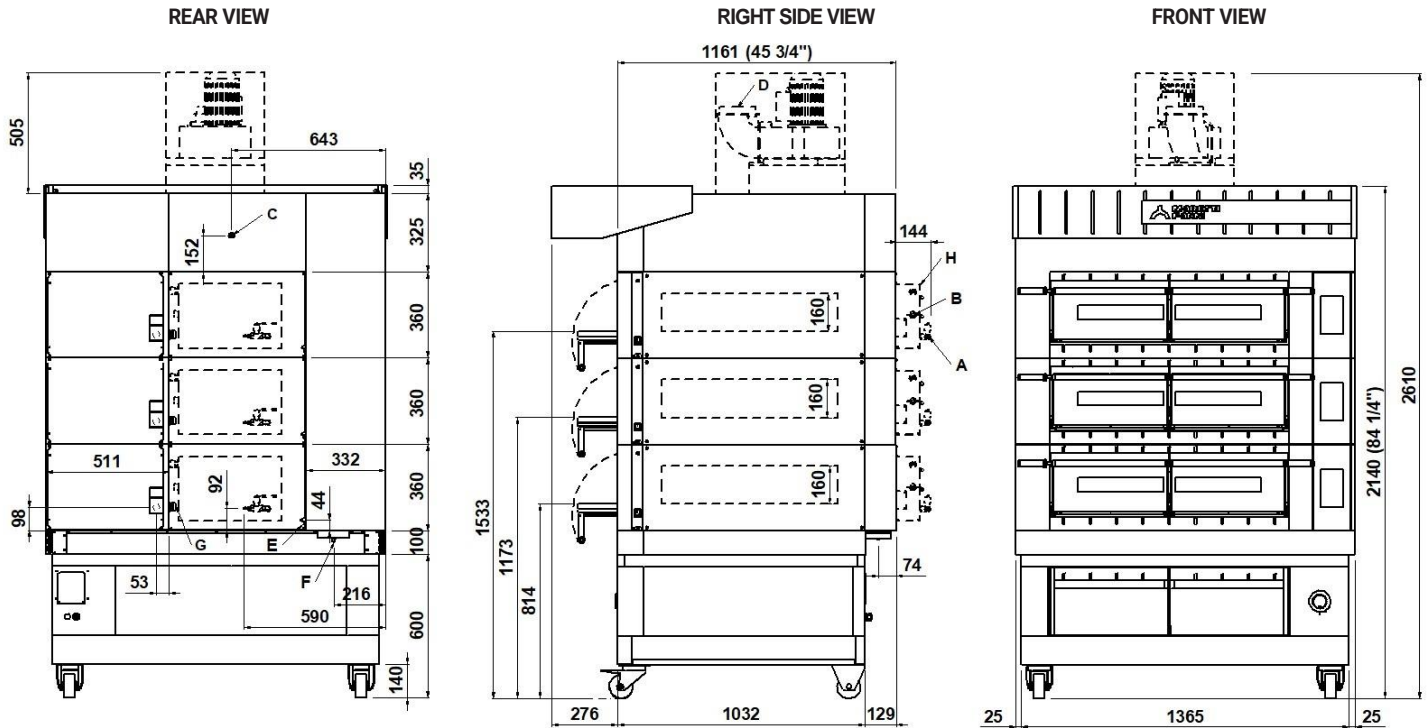

NOTE: The dimensions indicated in the views are in millimetres. \*Dimensions refer to the oversized hood.

|  |  |  |   |
|--|--|--|---|
| <b>A</b><br>ø8<br>steamer water outlet | <b>B</b><br>3/4" male<br>steamer water inlet | <b>C</b><br>Ø16<br>hood condensation exhaust | <b>D</b><br>Ø150<br>steam exhaust             |
| <b>E</b><br>M6<br>equipotential screws | <b>F</b><br>Ø12<br>condensation exhaust      | <b>G</b><br>fairleads                        | <b>H</b><br>steamer 1600W<br>(see data sheet) |

**DIMENSIONS**

|                 |        |
|-----------------|--------|
| External height | 1540mm |
| External depth  | 1161mm |
| External width  | 1431mm |
| Weight          | 623kg  |

**SHIPPING INFORMATION**

|                        |            |
|------------------------|------------|
| Packed in wooden crate | 1740mm     |
| Height                 | 1640mm     |
| Depth                  | 1640mm     |
| Width                  | 1640mm     |
| Weight                 | (623+70)kg |

**FEEDING AND POWER**

|                                   |                              |
|-----------------------------------|------------------------------|
| Standard feeding                  | A.C. V400 3N                 |
| Feeding on request                | A.C. V230 3                  |
| Frequency                         | 50/60Hz                      |
| Max power                         | 26,4kW                       |
| *Average power cons               | 7,2÷9,6kWh                   |
| Connecting cable for each chamber | type H07RN-F                 |
|                                   | 5x4mm <sup>2</sup> (V400 3N) |
|                                   | 4x6mm <sup>2</sup> (V230 3)  |
| Power supply (optional prover)    | A.C. V230 1N 50/60 Hz        |
| Max power                         | 1,5kW                        |
| *Average power cons               | 0,8kWh                       |
| Conn. Cable type                  | H07RN-F 3x1,5mm <sup>2</sup> |

**TOTAL BAKING CAPACITY**

|                      |    |
|----------------------|----|
| Tray (600x400 mm)    | 6  |
| Pizza diameter 350mm | 12 |
| Pizza diameter 450mm | 6  |

|                                     |            |
|-------------------------------------|------------|
| When combined with stand or prover: |            |
| Max height                          | 2350mm     |
| Max weight                          | (710+80)kg |

\* This value is subject to variation according to the way in which the equipment is used

NOTE: MORETTI FORNI S.P.A. reserves the right to modify the characteristics of the products illustrated in this publication without prior notice

**2 baking chambers height 16+22 cm**  
(assembled with prover height 800mm)

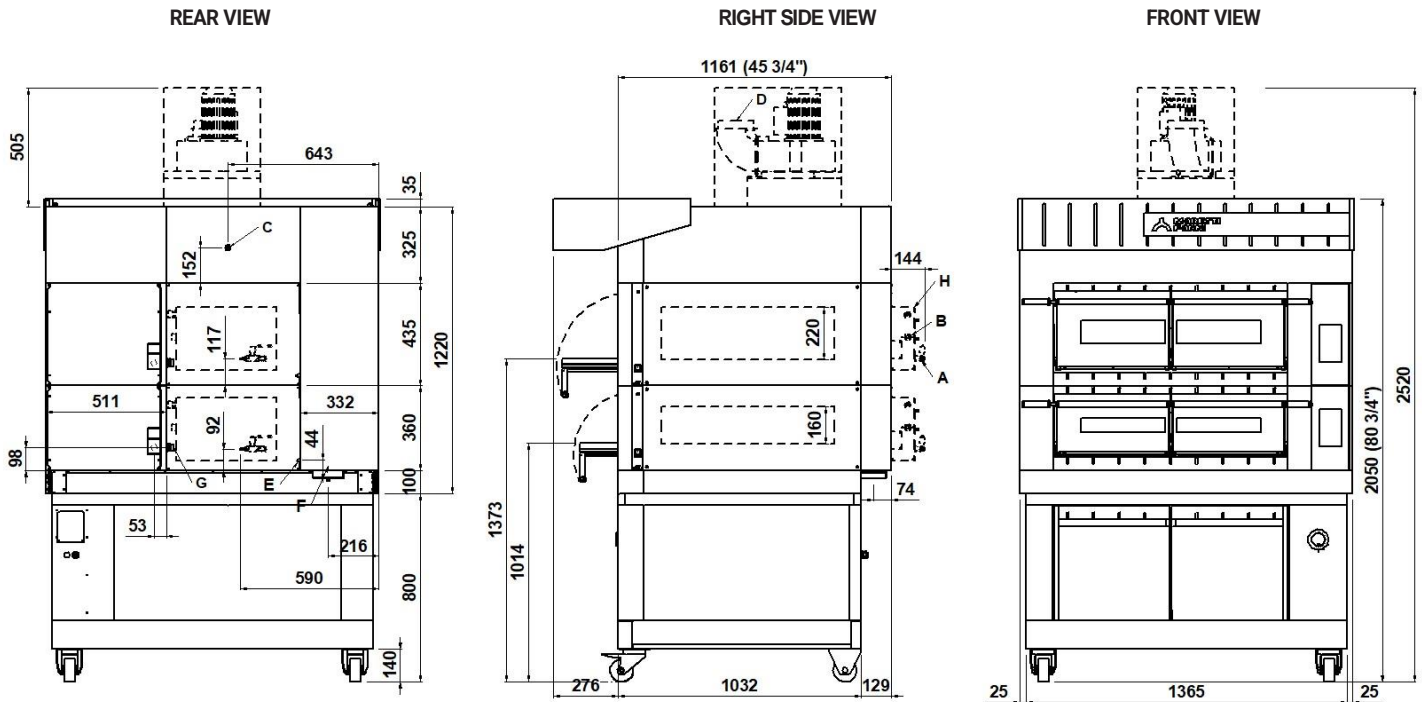

**NOTE:** The dimensions indicated in the views are in millimetres.

|  |  |  |   |
|--|--|--|---|
| <b>A</b><br>ø8<br>steamer water outlet | <b>B</b><br>3/4" male<br>steamer water inlet | <b>C</b><br>Ø16<br>hood condensation exhaust | <b>D</b><br>Ø150<br>steam exhaust             |
| <b>E</b><br>M6<br>equipotential screws | <b>F</b><br>Ø12<br>condensation exhaust      | <b>G</b><br>fairleads                        | <b>H</b><br>steamer 1600W<br>(see data sheet) |

**DIMENSIONI ESTERNE**

|                 |        |
|-----------------|--------|
| External height | 1255mm |
| External depth  | 1161mm |
| External width  | 1431mm |
| Weight          | 461kg  |

**TOTAL BAKING CAPACITY**

|                      |   |
|----------------------|---|
| Tray (600x400 mm)    | 4 |
| Pizza diameter 350mm | 8 |
| Pizza diameter 450mm | 4 |

**SHIPPING INFORMATION**

|                        |            |
|------------------------|------------|
| Packed in wooden crate |            |
| Height                 | 1455mm     |
| Depth                  | 1640mm     |
| Width                  | 1640mm     |
| Weight                 | (461+60)kg |

|                                     |            |
|-------------------------------------|------------|
| When combined with stand or prover: |            |
| Max height                          | 2255mm     |
| Max weight                          | (572+70)kg |

**FEEDING AND POWER**

|                                   |                      |
|-----------------------------------|----------------------|
| Standard feeding                  |                      |
| A.C. V400 3N                      |                      |
| Feeding on request                |                      |
| A.C. V230 3                       |                      |
| Frequency                         | 50/60Hz              |
| Max power                         | 17,6kW               |
| *Average power cons               | 4,8÷6,4kWh           |
| Connecting cable for each chamber |                      |
| type H07RN-F                      |                      |
| 5x4mm <sup>2</sup> (V400 3N)      |                      |
| 4x6mm <sup>2</sup> (V230 3)       |                      |
| Power supply (optional prover)    |                      |
| A.C. V230 1N 50/60 Hz             |                      |
| Max power                         | 1,5kW                |
| *Average power cons               | 0,8kWh               |
| Conn. Cable type H07RN-F          | 3x1,5mm <sup>2</sup> |

\* This value is subject to variation according to the way in which the equipment is used  
NOTE: MORETTI FORNI S.P.A. reserves the right to modify the characteristics of the products illustrated in this publication without prior notice

**3 baking chambers height 16+16+22 cm**  
(assembled with prover height 600mm)

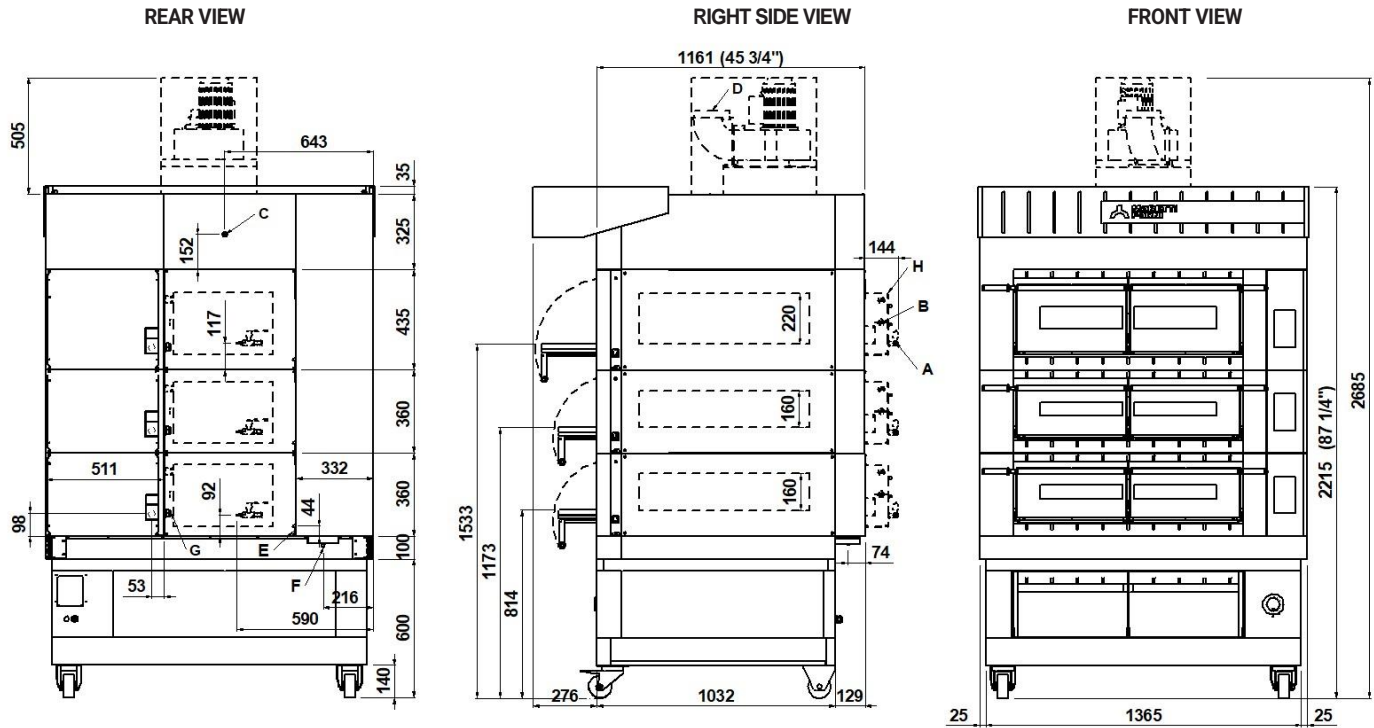

**NOTE:** The dimensions indicated in the views are in millimetres. \*Dimensions refer to the oversized hood.

|  |  |  |   |
|--|--|--|---|
| <b>A</b><br>ø8<br>steamer water outlet | <b>B</b><br>3/4" male<br>steamer water inlet | <b>C</b><br>Ø16<br>hood condensation exhaust | <b>D</b><br>Ø150<br>steam exhaust             |
| <b>E</b><br>M6<br>equipotential screws | <b>F</b><br>Ø12<br>condensation exhaust      | <b>G</b><br>fairleads                        | <b>H</b><br>steamer 1600W<br>(see data sheet) |

**DIMENSIONS**

|                 |        |
|-----------------|--------|
| External height | 1615mm |
| External depth  | 1161mm |
| External width  | 1431mm |
| Weight          | 634kg  |

**SHIPPING INFORMATION**

|                        |            |
|------------------------|------------|
| Packed in wooden crate | 1815mm     |
| Height                 | 1640mm     |
| Depth                  | 1640mm     |
| Width                  | (634+70)kg |
| Weight                 |            |

**FEEDING AND POWER**

|   |            |
|---|------------|
| Standard feeding                              |            |
| A.C. V400 3N                                  |            |
| Feeding on request                            |            |
| A.C. V230 3                                   |            |
| Frequency                                     | 50/60Hz    |
| Max power                                     | 26,4kW     |
| *Average power cons                           | 7,2÷9,6kWh |
| Connecting cable for each chamber             |            |
| type H07RN-F                                  |            |
| 5x4mm <sup>2</sup> (V400 3N)                  |            |
| 4x6mm <sup>2</sup> (V230 3)                   |            |
| Power supply (optional prover)                |            |
| A.C. V230 1N 50/60 Hz                         |            |
| Max power                                     | 1,5kW      |
| *Average power cons                           | 0,8kWh     |
| Conn. Cable type H07RN-F 3x1,5mm <sup>2</sup> |            |

**TOTAL BAKING CAPACITY**

|                      |    |
|----------------------|----|
| Tray (600x400 mm)    | 6  |
| Pizza diameter 350mm | 12 |
| Pizza diameter 450mm | 6  |

|                                     |            |
|-------------------------------------|------------|
| When combined with stand or prover: |            |
| Max height                          | 2415mm     |
| Max weight                          | (721+80)kg |

\* This value is subject to variation according to the way in which the equipment is used

**NOTE:** MORETTI FORNI S.P.A. reserves the right to modify the characteristics of the products illustrated in this publication without prior notice

**X100**  
TECHNICAL DATA

| <b>SHIPPING INFORMATION H16</b>    |              | <b>X100E_1_16</b> | <b>X100E_2_16</b> | <b>X100E_3_16</b> |
|------------------------------------|--------------|-------------------|-------------------|-------------------|
| Packed in wooden crate             | Height       | 1020mm            | 1380mm            | 1740mm            |
|                                    | Weight       | (278+50)kg        | (451+60)kg        | (623+70)kg        |
| When combined with prover or Stand | Max. height. | 1970mm            | 2200mm            | 2350mm            |
|                                    | Max. weight. | (389+60)kg        | (562+70)kg        | (710+80)kg        |
| <b>SHIPPING INFORMATION H22</b>    |              | <b>X510E_1_22</b> | <b>X100E_2_22</b> | <b>X100E_3_22</b> |
| Packed in wooden crate             | Height       | 1095mm            | 1530mm            | 1965mm            |
|                                    | Weight       | (289+50)kg        | (472+60)kg        | (655+70)kg        |
| When combined with prover or Stand | Max. height. | 2045mm            | 2330mm            | 2565mm            |
|                                    | Max. weight. | (400+60)kg        | (583+70)kg        | (742+80)kg        |

\* This value is subject to variation according to the way in which the equipment is used  
NOTE: MORETTI FORNI S.P.A. reserves the right to modify the characteristics of the products illustrated in this publication without prior notice



## Modular electric deck oven 2 decks composition

**serieX** is the first oven in the market equipped with **Any Chef™ Technology**, able to autonomously set the **perfect baking cycle for any kind of product**.

Ideal for **Any Business**, serieX grants a substantial saving in h/operator costs. Specific for **Any Product**, can fit **in Any Place**, thanks to energy consumption reduced by 45%.

The **intuitive interface** makes serieX suitable for **Any Chef**: everyone can be a baking master of **pizza, bread, pastry and gastronomy**. By choosing your recipe parameters, serieX will automatically set the temperature and baking time, and the user-friendly **TFT Touch display will show the best area to place the product**.

serieX takes the oven to another level: not only a tool, but also a **precious partner to which delegate part of your daily work**.



### OPERATION

- Heated by highly performing armoured heating elements, working independently in each baking area
- SmartDeck™: thanks to the sensor system in each baking area, the heat is supplied only where needed, automatically regulating the heating elements power according to product type and quantity. The display always suggests the best area to use, allowing the right surface rotation and utilising heat at its best. The system determines the workload and automatically sets Auto EcoStandby™ for pauses or Auto PowerBooster™ for work peaks
- Adaptive BakingTime™ thanks to the software algorithm, the baking time adapts depending both on the heat quantity detected and on the product in the baking area
- Pre-set cycles with variable phases specific for bread, pastry and gastronomy products
- UI with intuitive sliders that allow to easily customise the baking result. Mapping is optimised for every product
- AdaptivePower® Technology: power management with P.I.D. permits automatic energy regulation based on the quantity of product baked
- DualPower+™: ceiling / floor temperature and power can be managed separately and simultaneously
- Continuous temperature detection inside the baking chamber through 2 thermocouples
- Optimal heat balancing since the first baking
- Automatic pyrolytic cleaning program, PowerCleaning™
- Self-limited temperature at 400°C
- Vapour discharge by programmable steam valve

### CONSTRUCTION

- Front structure made of bent stainless steel with Steel-X finishing inserts
- Side panels in painted metal sheet
- Channel hood
- Separable doors with total or partial opening available in every moment
- Stainless steel door with external fairing for better insulation and safety
- Brushed stainless steel handles made with antiseptic finish
- Refractory brick baking surface
- Side and top internal structure made of aluminised steel
- Internal rear-view mirrors made of reflecting steel suitable for high temperatures (not applied for decks equipped with steamer)
- Oriented double LED light, placed in a protected position
- Heat insulation CoolAround® Technology

### INTERNAL BAKING CHAMBER DIMENSIONS

|                 |                   |
|-----------------|-------------------|
| Internal height | 160mm             |
| Internal depth  | 735mm             |
| Internal width  | 950mm             |
| Baking surface  | 0,7m <sup>2</sup> |

### ACCESSORIES

- Prover with wheels height 600, 800mm
- Stand with wheels height 400, 600, 800, 950, 1050mm
- Programmable steamer with steam regulation
- Additional tray holder guides for prover and stand
- Soundproof motor for hood 500 m3/h
- Front hood spacer element 40mm high
- Frontless hood H=175 mm
- Door opening upwards
- Multipoint core probe
- Self-condensing hood
- Remote-Master® Technology

### STANDARD EQUIPMENT

- Multilanguage, antiglare, colour display TFT Touch 7" IPS
- Customisable baking cycles according to your dough
- 4 different working modes: Bake, Regenerate, Prebake, Refining®
- Auto EcoStandby™ for work pauses
- Auto PowerBooster™ for work peaks
- Oven front/rear and right/left power balance DeltaPower+™
- ReadyToGo Timer, optimised switch on based on baking time set. Two daily start and stop programmable.
- FlexLoad™ automatically identifies where the work load is activating the heating elements in the corresponding area
- Self-diagnosis with error message on display
- Multi timer
- Maximum temperature independent safety device
- USB port and WiFi module for software update
- SmartBaking app

### TOP VIEW

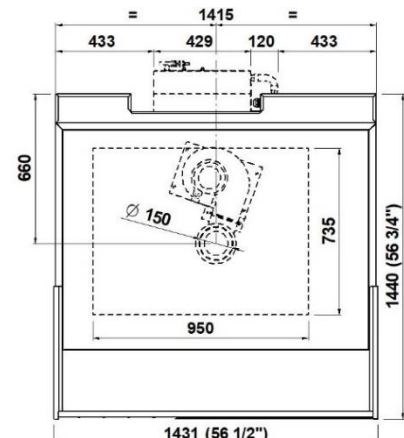

**1 baking chamber height 16cm**  
(assembled with stand height 950mm)

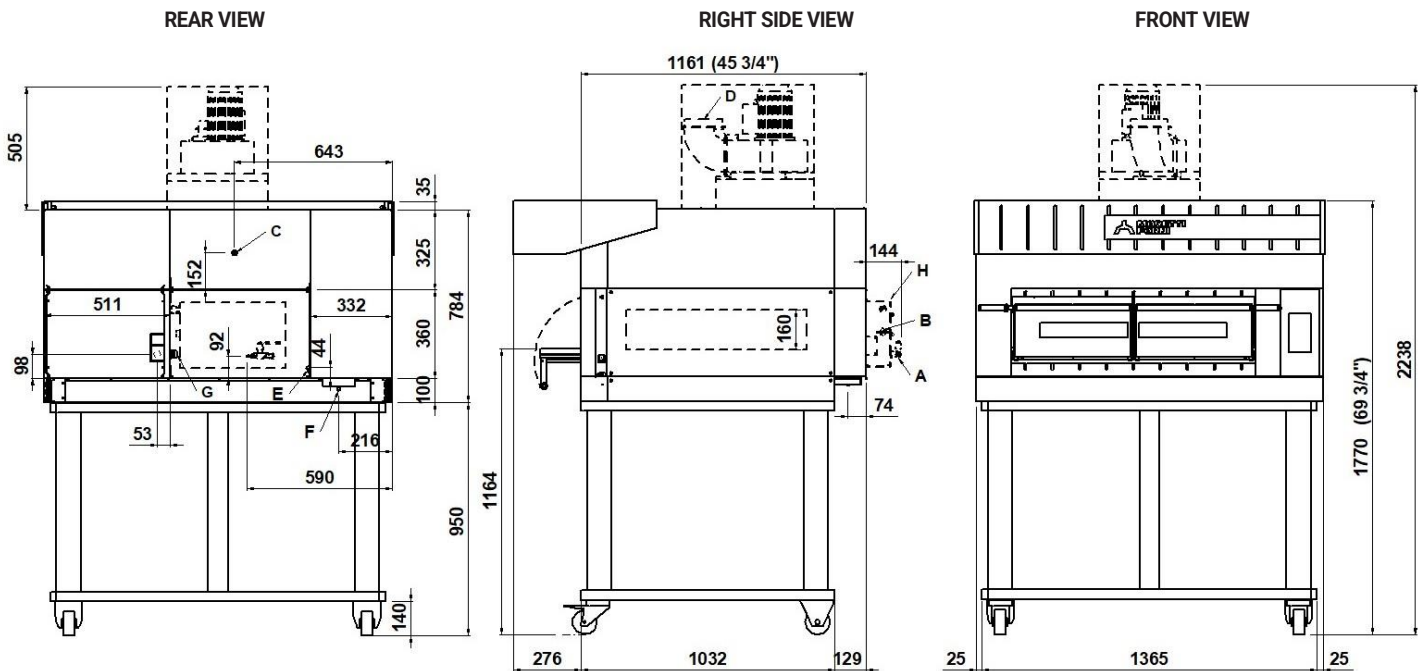

**NOTE:** The dimensions indicated in the views are in millimetres.

|  |  |  |   |
|--|--|--|---|
| <b>A</b><br>ø8<br>steamer water outlet | <b>B</b><br>3/4" male<br>steamer water inlet | <b>C</b><br>Ø16<br>hood condensation exhaust | <b>D</b><br>Ø150<br>steam exhaust             |
| <b>E</b><br>M6<br>equipotential screws | <b>F</b><br>Ø12<br>condensation exhaust      | <b>G</b><br>fairleads                        | <b>H</b><br>Steamer 1600W<br>(see data sheet) |

**DIMENSIONS**

|                 |        |
|-----------------|--------|
| External height | 820mm  |
| External depth  | 1161mm |
| External width  | 1431mm |
| Weight          | 278kg  |

**TOTAL BAKING CAPACITY**

|                      |   |
|----------------------|---|
| Tray (600x400mm)     | 2 |
| Pizza diameter 350mm | 4 |
| Pizza diameter 450mm | 2 |

**SHIPPING INFORMATION**

|                                     |            |
|-------------------------------------|------------|
| Packed in wooden crate              |            |
| Height                              | 1020mm     |
| Depth                               | 1640mm     |
| Width                               | 1640mm     |
| Weight                              | (278+50)kg |
| When combined with stand or prover: |            |
| Max height                          | 1970mm     |
| Max weight                          | (389+60)kg |

**FEEDING AND POWER**

|                                   |                      |
|-----------------------------------|----------------------|
| Standard feeding                  |                      |
| A.C. V400 3N                      |                      |
| Feeding on request                |                      |
| A.C. V230 3                       |                      |
| Frequency                         | 50/60Hz              |
| Max power                         | 8,8kW                |
| *Average power cons.              | 2,4÷3,2kWh           |
| Connecting cable for each chamber |                      |
| type H07RN-F                      |                      |
| 5x4mm <sup>2</sup> (V400 3N)      |                      |
| 4x6mm <sup>2</sup> (V230 3)       |                      |
| Power supply (optional prover)    |                      |
| A.C. V230 1N 50/60 Hz             |                      |
| Max power                         | 1,5kW                |
| *Average power cons.              | 0,8kWh               |
| Conn. Cable type H07RN-F          | 3x1,5mm <sup>2</sup> |

\* This value is subject to variation according to the way in which the equipment is used

**NOTE:** MORETTI FORNI S.P.A. reserves the right to modify the characteristics of the products illustrated in this publication without prior notice

**2 baking chambers height 16cm**  
(assembled with prover height 800mm)

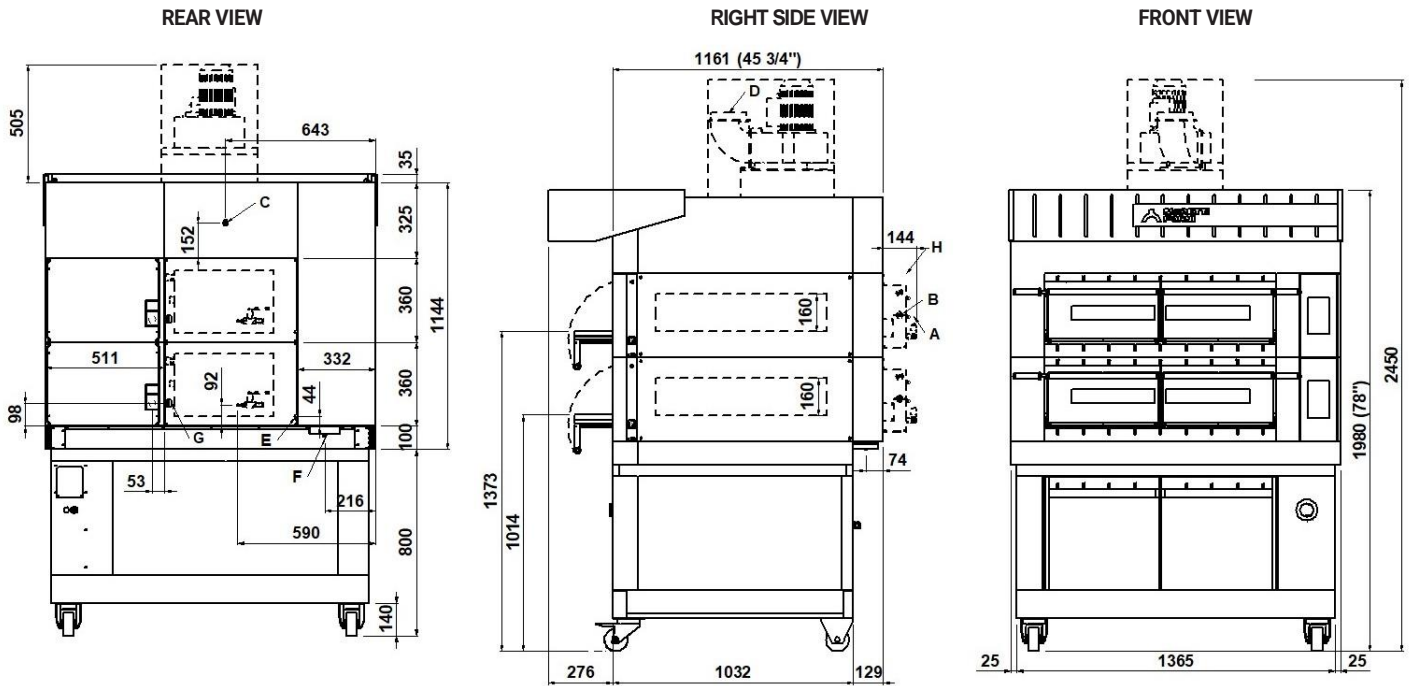

**NOTE:** The dimensions indicated in the views are in millimetres.

|  |  |  |   |
|--|--|--|---|
| <b>A</b><br>ø8<br>steamer water outlet | <b>B</b><br>3/4" male<br>steamer water inlet | <b>C</b><br>Ø16<br>hood condensation exhaust | <b>D</b><br>Ø150<br>steam exhaust             |
| <b>E</b><br>M6<br>equipotential screws | <b>F</b><br>Ø12<br>condensation exhaust      | <b>G</b><br>fairleads                        | <b>H</b><br>steamer 1600W<br>(see data sheet) |

**DIMENSIONS**

|                 |        |
|-----------------|--------|
| External height | 1180mm |
| External depth  | 1161mm |
| External width  | 1431mm |
| Weight          | 451kg  |

**TOTAL BAKING CAPACITY**

|                      |   |
|----------------------|---|
| Tray (600x400 mm)    | 4 |
| Pizza diameter 350mm | 8 |
| Pizza diameter 450mm | 4 |

**SHIPPING INFORMATION**

|                        |            |
|------------------------|------------|
| Packed in wooden crate |            |
| Height                 | 1380mm     |
| Depth                  | 1640mm     |
| Width                  | 1640mm     |
| Weight                 | (451+60)kg |

|                                     |            |
|-------------------------------------|------------|
| When combined with stand or prover: |            |
| Max height                          | 2200mm     |
| Max weight                          | (562+70)kg |

**FEEDING AND POWER**

|                                   |                      |
|-----------------------------------|----------------------|
| Standard feeding                  |                      |
| A.C. V400 3N                      |                      |
| Feeding on request                |                      |
| A.C. V230 3                       |                      |
| Frequency                         | 50/60Hz              |
| Max power                         | 17,6kW               |
| *Average power cons               | 4,8÷6,4kWh           |
| Connecting cable for each chamber |                      |
| type H07RN-F                      |                      |
| 5x4mm <sup>2</sup> (V400 3N)      |                      |
| 4x6mm <sup>2</sup> (V230 3)       |                      |
| Power supply (optional prover)    |                      |
| A.C. V230 1N 50/60 Hz             |                      |
| Max power                         | 1,5kW                |
| *Average power cons               | 0,8kWh               |
| Conn. Cable type H07RN-F          | 3x1,5mm <sup>2</sup> |

\* This value is subject to variation according to the way in which the equipment is used  
NOTE: MORETTI FORNI S.P.A. reserves the right to modify the characteristics of the products illustrated in this publication without prior notice

**3 baking chambers height 16 cm**  
(assembled with prover height 600mm)

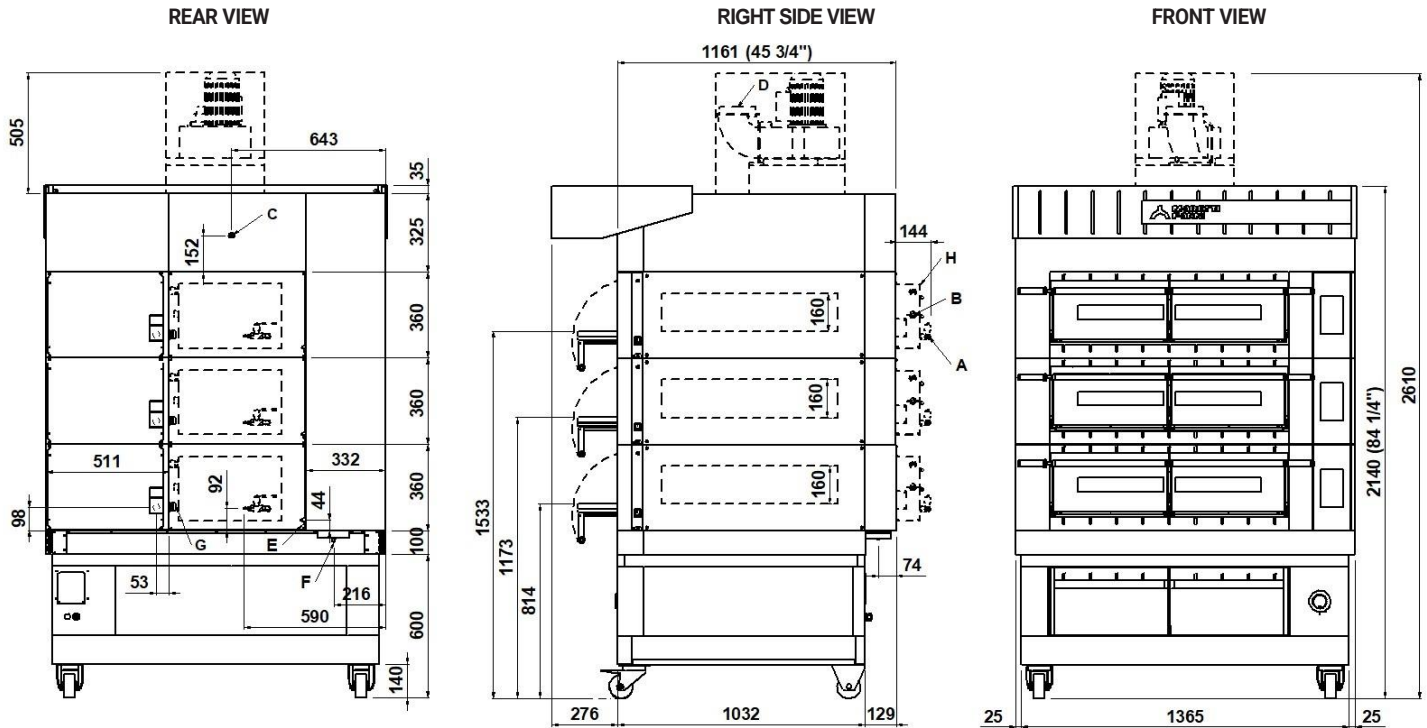

NOTE: The dimensions indicated in the views are in millimetres. \*Dimensions refer to the oversized hood.

|  |  |  |   |
|--|--|--|---|
| <b>A</b><br>ø8<br>steamer water outlet | <b>B</b><br>3/4" male<br>steamer water inlet | <b>C</b><br>Ø16<br>hood condensation exhaust | <b>D</b><br>Ø150<br>steam exhaust             |
| <b>E</b><br>M6<br>equipotential screws | <b>F</b><br>Ø12<br>condensation exhaust      | <b>G</b><br>fairleads                        | <b>H</b><br>steamer 1600W<br>(see data sheet) |

**DIMENSIONS**

|                 |        |
|-----------------|--------|
| External height | 1540mm |
| External depth  | 1161mm |
| External width  | 1431mm |
| Weight          | 623kg  |

**SHIPPING INFORMATION**

|                        |            |
|------------------------|------------|
| Packed in wooden crate | 1740mm     |
| Height                 | 1640mm     |
| Depth                  | 1640mm     |
| Width                  | 1640mm     |
| Weight                 | (623+70)kg |

**FEEDING AND POWER**

|                                   |                              |
|-----------------------------------|------------------------------|
| Standard feeding                  | A.C. V400 3N                 |
| Feeding on request                | A.C. V230 3                  |
| Frequency                         | 50/60Hz                      |
| Max power                         | 26,4kW                       |
| *Average power cons               | 7,2÷9,6kWh                   |
| Connecting cable for each chamber | type H07RN-F                 |
|                                   | 5x4mm <sup>2</sup> (V400 3N) |
|                                   | 4x6mm <sup>2</sup> (V230 3)  |
| Power supply (optional prover)    | A.C. V230 1N 50/60 Hz        |
| Max power                         | 1,5kW                        |
| *Average power cons               | 0,8kWh                       |
| Conn. Cable type                  | H07RN-F 3x1,5mm <sup>2</sup> |

**TOTAL BAKING CAPACITY**

|                      |    |
|----------------------|----|
| Tray (600x400 mm)    | 6  |
| Pizza diameter 350mm | 12 |
| Pizza diameter 450mm | 6  |

|                                     |            |
|-------------------------------------|------------|
| When combined with stand or prover: |            |
| Max height                          | 2350mm     |
| Max weight                          | (710+80)kg |

\* This value is subject to variation according to the way in which the equipment is used

NOTE: MORETTI FORNI S.P.A. reserves the right to modify the characteristics of the products illustrated in this publication without prior notice

**2 baking chambers height 16+22 cm**  
(assembled with prover height 800mm)

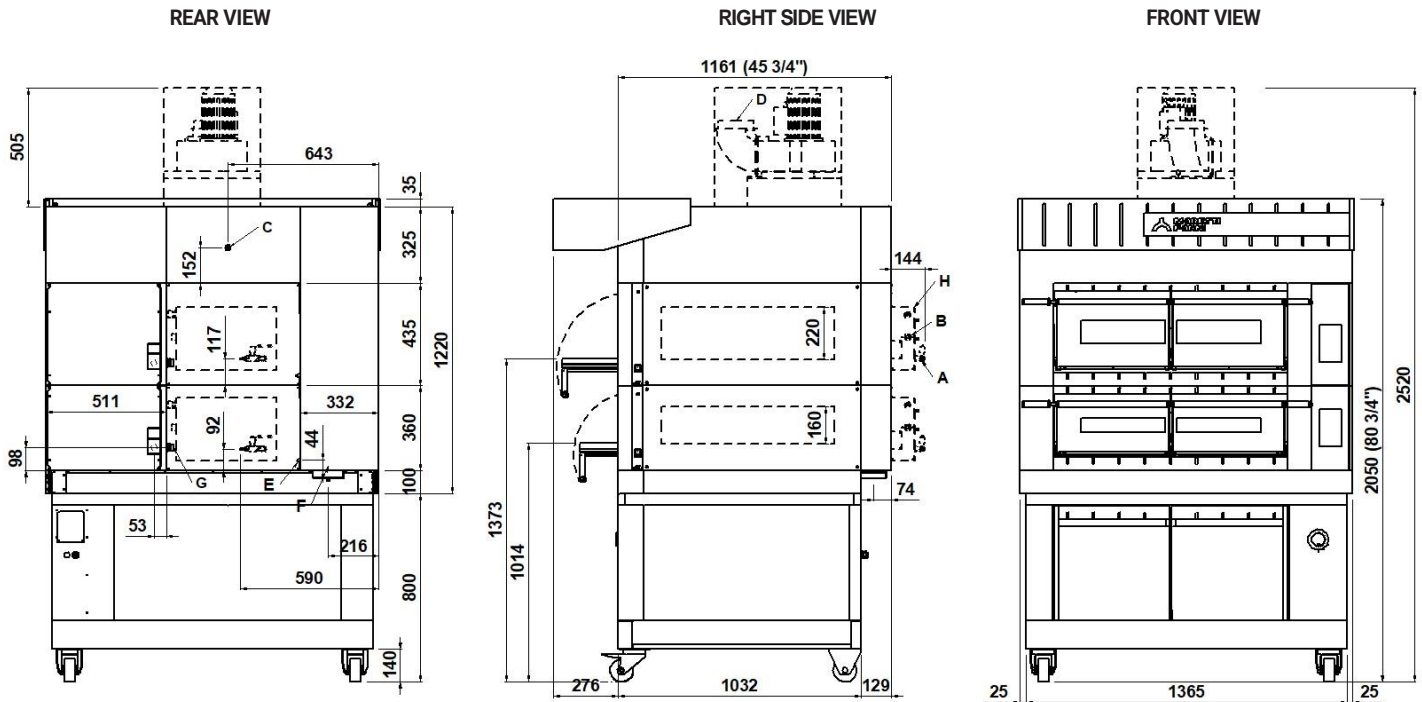

**NOTE:** The dimensions indicated in the views are in millimetres.

|  |  |  |   |
|--|--|--|---|
| <b>A</b><br>ø8<br>steamer water outlet | <b>B</b><br>3/4" male<br>steamer water inlet | <b>C</b><br>Ø16<br>hood condensation exhaust | <b>D</b><br>Ø150<br>steam exhaust             |
| <b>E</b><br>M6<br>equipotential screws | <b>F</b><br>Ø12<br>condensation exhaust      | <b>G</b><br>fairleads                        | <b>H</b><br>steamer 1600W<br>(see data sheet) |

**DIMENSIONI ESTERNE**

|                 |        |
|-----------------|--------|
| External height | 1255mm |
| External depth  | 1161mm |
| External width  | 1431mm |
| Weight          | 461kg  |

**TOTAL BAKING CAPACITY**

|                      |   |
|----------------------|---|
| Tray (600x400 mm)    | 4 |
| Pizza diameter 350mm | 8 |
| Pizza diameter 450mm | 4 |

**SHIPPING INFORMATION**

|                        |            |
|------------------------|------------|
| Packed in wooden crate |            |
| Height                 | 1455mm     |
| Depth                  | 1640mm     |
| Width                  | 1640mm     |
| Weight                 | (461+60)kg |

|                                     |            |
|-------------------------------------|------------|
| When combined with stand or prover: |            |
| Max height                          | 2255mm     |
| Max weight                          | (572+70)kg |

**FEEDING AND POWER**

|                                   |                      |
|-----------------------------------|----------------------|
| Standard feeding                  |                      |
| A.C. V400 3N                      |                      |
| Feeding on request                |                      |
| A.C. V230 3                       |                      |
| Frequency                         | 50/60Hz              |
| Max power                         | 17,6kW               |
| *Average power cons               | 4,8÷6,4kWh           |
| Connecting cable for each chamber |                      |
| type H07RN-F                      |                      |
| 5x4mm <sup>2</sup> (V400 3N)      |                      |
| 4x6mm <sup>2</sup> (V230 3)       |                      |
| Power supply (optional prover)    |                      |
| A.C. V230 1N 50/60 Hz             |                      |
| Max power                         | 1,5kW                |
| *Average power cons               | 0,8kWh               |
| Conn. Cable type H07RN-F          | 3x1,5mm <sup>2</sup> |

\* This value is subject to variation according to the way in which the equipment is used  
NOTE: MORETTI FORNI S.P.A. reserves the right to modify the characteristics of the products illustrated in this publication without prior notice

**3 baking chambers height 16+16+22 cm**  
(assembled with prover height 600mm)

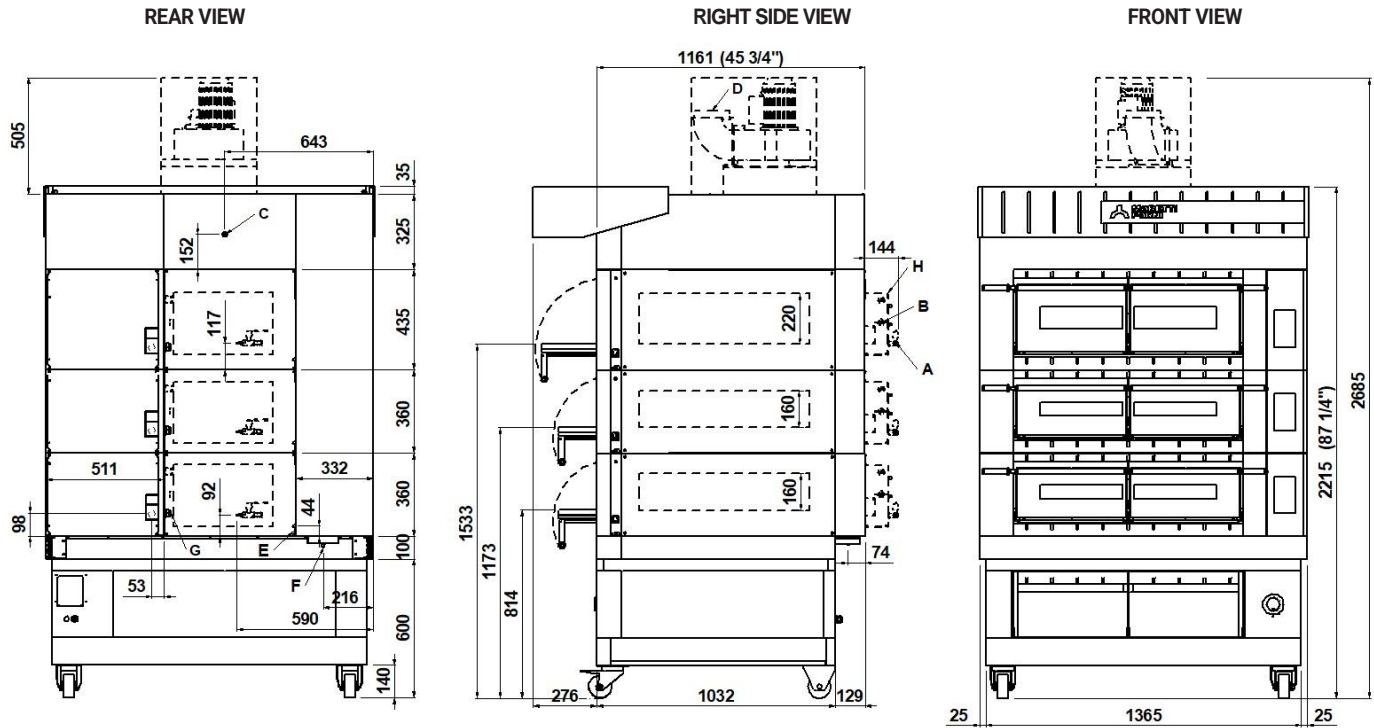

**NOTE:** The dimensions indicated in the views are in millimetres. \*Dimensions refer to the oversized hood.

|  |  |  |   |
|--|--|--|---|
| <b>A</b><br>ø8<br>steamer water outlet | <b>B</b><br>3/4" male<br>steamer water inlet | <b>C</b><br>Ø16<br>hood condensation exhaust | <b>D</b><br>Ø150<br>steam exhaust             |
| <b>E</b><br>M6<br>equipotential screws | <b>F</b><br>Ø12<br>condensation exhaust      | <b>G</b><br>fairleads                        | <b>H</b><br>steamer 1600W<br>(see data sheet) |

**DIMENSIONS**

|                 |        |
|-----------------|--------|
| External height | 1615mm |
| External depth  | 1161mm |
| External width  | 1431mm |
| Weight          | 634kg  |

**SHIPPING INFORMATION**

|                        |            |
|------------------------|------------|
| Packed in wooden crate | 1815mm     |
| Height                 | 1640mm     |
| Depth                  | 1640mm     |
| Width                  | (634+70)kg |
| Weight                 |            |

**FEEDING AND POWER**

|                                   |                      |
|-----------------------------------|----------------------|
| Standard feeding                  |                      |
| A.C. V400 3N                      |                      |
| Feeding on request                |                      |
| A.C. V230 3                       |                      |
| Frequency                         | 50/60Hz              |
| Max power                         | 26,4kW               |
| *Average power cons               | 7,2÷9,6kWh           |
| Connecting cable for each chamber |                      |
| type H07RN-F                      |                      |
| 5x4mm <sup>2</sup> (V400 3N)      |                      |
| 4x6mm <sup>2</sup> (V230 3)       |                      |
| Power supply (optional prover)    |                      |
| A.C. V230 1N 50/60 Hz             |                      |
| Max power                         | 1,5kW                |
| *Average power cons               | 0,8kWh               |
| Conn. Cable type H07RN-F          | 3x1,5mm <sup>2</sup> |

**TOTAL BAKING CAPACITY**

|                      |    |
|----------------------|----|
| Tray (600x400 mm)    | 6  |
| Pizza diameter 350mm | 12 |
| Pizza diameter 450mm | 6  |

|                                     |            |
|-------------------------------------|------------|
| When combined with stand or prover: |            |
| Max height                          | 2415mm     |
| Max weight                          | (721+80)kg |

\* This value is subject to variation according to the way in which the equipment is used

**NOTE:** MORETTI FORNI S.P.A. reserves the right to modify the characteristics of the products illustrated in this publication without prior notice

**X100**  
TECHNICAL DATA

| <b>SHIPPING INFORMATION H16</b>    |              | <b>X100E_1_16</b> | <b>X100E_2_16</b> | <b>X100E_3_16</b> |
|------------------------------------|--------------|-------------------|-------------------|-------------------|
| Packed in wooden crate             | Height       | 1020mm            | 1380mm            | 1740mm            |
|                                    | Weight       | (278+50)kg        | (451+60)kg        | (623+70)kg        |
| When combined with prover or Stand | Max. height. | 1970mm            | 2200mm            | 2350mm            |
|                                    | Max. weight. | (389+60)kg        | (562+70)kg        | (710+80)kg        |
| <b>SHIPPING INFORMATION H22</b>    |              | <b>X510E_1_22</b> | <b>X100E_2_22</b> | <b>X100E_3_22</b> |
| Packed in wooden crate             | Height       | 1095mm            | 1530mm            | 1965mm            |
|                                    | Weight       | (289+50)kg        | (472+60)kg        | (655+70)kg        |
| When combined with prover or Stand | Max. height. | 2045mm            | 2330mm            | 2565mm            |
|                                    | Max. weight. | (400+60)kg        | (583+70)kg        | (742+80)kg        |

\* This value is subject to variation according to the way in which the equipment is used  
NOTE: MORETTI FORNI S.P.A. reserves the right to modify the characteristics of the products illustrated in this publication without prior notice