



Modular electric deck oven 2 decks composition

serieX is the first oven in the market equipped with **Any Chef™ Technology**, able to autonomously set the **perfect baking cycle for any kind of product**.

Ideal for **Any Business**, serieX grants a substantial saving in h/operator costs. Specific for **Any Product**, can fit **in Any Place**, thanks to energy consumption reduced by 45%.

The **intuitive interface** makes serieX suitable for **Any Chef**: everyone can be a baking master of **pizza, bread, pastry and gastronomy**. By choosing your recipe parameters, serieX will automatically set the temperature and baking time, and the user-friendly **TFT Touch display will show the best area to place the product**.

serieX takes the oven to another level: not only a tool, but also a **precise partner to which delegate part of your daily work**.



OPERATION

- Heated by highly performing armoured heating elements, working independently in each baking area
- SmartDeck™: thanks to the sensor system in each baking area, the heat is supplied only where needed, automatically regulating the heating elements power according to product type and quantity. The display always suggests the best area to use, allowing the right surface rotation and utilising heat at its best. The system determines the workload and automatically sets Auto EcoStandby™ for pauses or Auto PowerBooster™ for work peaks
- Adaptive BakingTime™ thanks to the software algorithm, the baking time adapts depending both on the heat quantity detected and on the product in the baking area
- Pre-set cycles with variable phases specific for bread, pastry and gastronomy products
- UI with intuitive sliders that allow to easily customise the baking result. Mapping is optimised for every product
- AdaptivePower® Technology: power management with P.I.D. permits automatic energy regulation based on the quantity of product baked
- DualPower+™: ceiling / floor temperature and power can be managed separately and simultaneously
- Continuous temperature detection inside the baking chamber through thermocouple
- Optimal heat balancing since the first baking
- Automatic pyrolytic cleaning program, PowerCleaning™
- Self-limited temperature at 400°C
- Vapour discharge by programmable steam valve

CONSTRUCTION

- Front structure made of bent stainless steel
- Side panels in painted metal sheet
- Frontless hood
- Stainless steel door with external fairing for better insulation and safety
- Brushed stainless steel handles made with antiseptic finish
- Refractory brick baking surface
- Side and top internal structure made of aluminised steel
- Internal rear-view mirrors made of reflecting steel suitable for high temperatures (not applied for decks equipped with steamer)
- Oriented double LED light, placed in a protected position
- Heat insulation CoolAround® Technology

INTERNAL BAKING CHAMBER DIMENSIONS

Internal height	160mm
Internal depth	735mm
Internal width	475mm
Baking surface	0,35m ²

ACCESSORIES

- Prover with wheels height 600, 800mm
- Stand with wheels height 400, 600, 800, 950, 1050mm
- Additional tray holder guides for prover and stand
- Programmable steamer with steam regulation
- Door opening upwards
- Multipoint core probe
- Self-condensing hood
- Kit support feet for countertop installation H=15mm
- Remote-Master® Technology

STANDARD EQUIPMENT

- Multilanguage, antiglare, colour display TFT Touch 7" IPS
- Customisable baking cycles according to your dough
- 4 different working modes: Bake, Regenerate, Prebake, Refining®
- Auto EcoStandby™ for work pauses
- Auto PowerBooster™ for work peaks
- Oven front/rear power balance DeltaPower+™
- ReadyToGo Timer, optimised switch on based on baking time set. Two daily start and stop programmable.
- FlexLoad™ automatically identifies where the work load is activating the heating elements in the corresponding area
- Self-diagnosis with error message on display
- Multi timer
- Maximum temperature independent safety device
- USB port and WiFi module for software update
- SmartBaking app

TOP VIEW

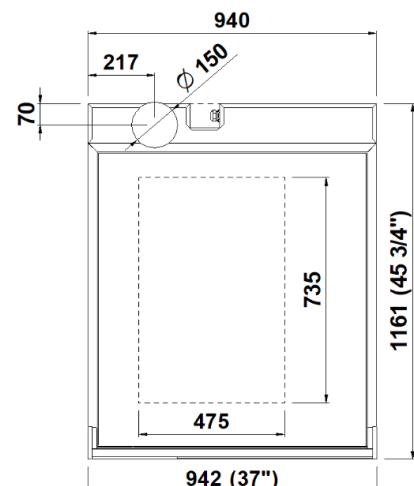

1 baking chamber height 16cm
(assembled with stand height 950mm)

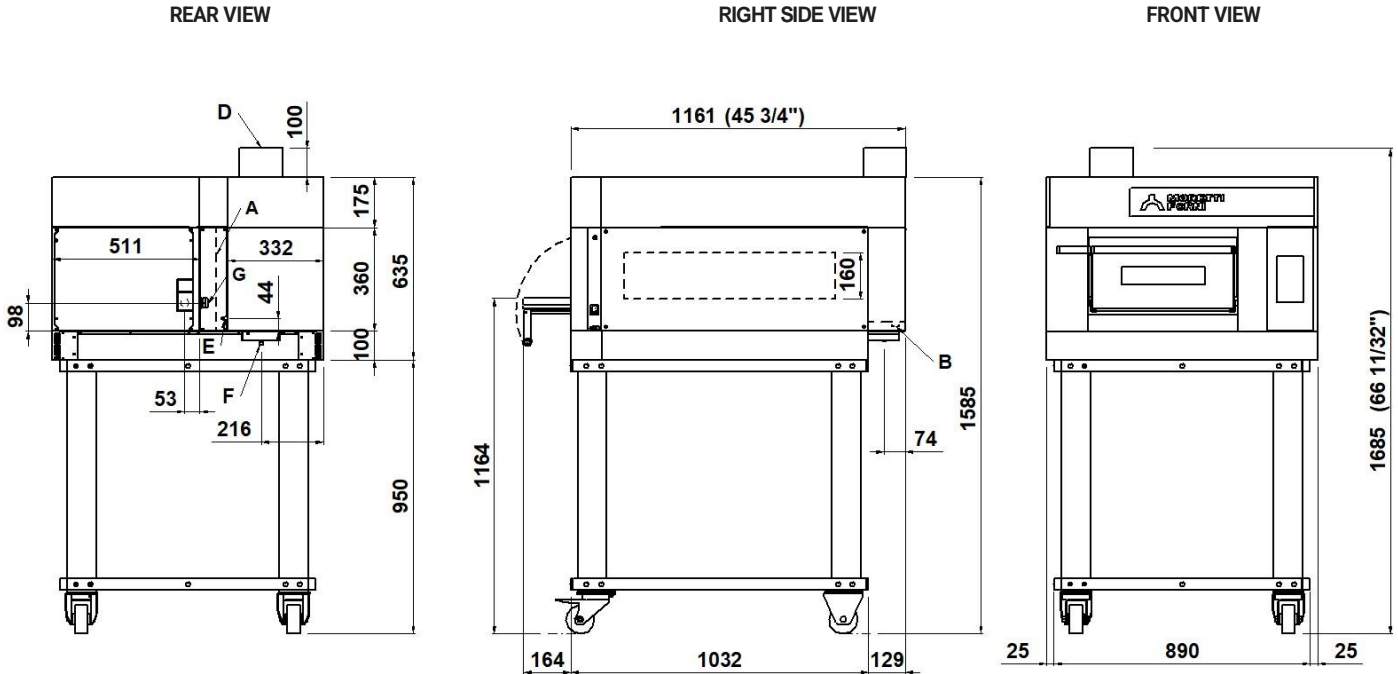

NOTE: The dimensions indicated in the views are in millimetres.

A steamer 1200W (see data sheet)	B 3/4" male steamer water inlet	D Ø150 steam exhaust	E M6 equipotential screws
F Ø12 condensation exhaust	G fairleads		

DIMENSIONS

External height	635mm
External depth	1161mm
External width	942mm
Weight	163kg

SHIPPING INFORMATION

Packed in wooden crate	
Height	835mm
Depth	1360mm
Width	1150mm
Weight	(163+50)kg

FEEDING AND POWER

Standard feeding	
A.C. V400 3N	
Feeding on request	
A.C. V230 3	
Frequency	50/60Hz
Max power	4,4kW
*Average power cons	1,2÷1,6kWh
Connecting cable for each chamber	
type H07RN-F	
5x2,5mm ² (V400 3N)	
4x4mm ² (V230 3)	
Power supply (optional prover)	
A.C. V230 1N 50/60 Hz	
Max power	1,5kW
*Average power cons	0,8kWh
Conn. Cable type H07RN-F	3x1,5mm ²

TOTAL BAKING CAPACITY

Tray (600x400 mm)	1	When combined with stand or prover:	
Pizza diameter 350mm	2	Max height	1785mm
Pizza diameter 450mm	1	Max weight	(228+60)kg

* This value is subject to variation according to the way in which the equipment is used

NOTE: MORETTI FORNI S.P.A. reserves the right to modify the characteristics of the products illustrated in this publication without prior notice

2 baking chambers height 16cm
(assembled with prover height 800mm)

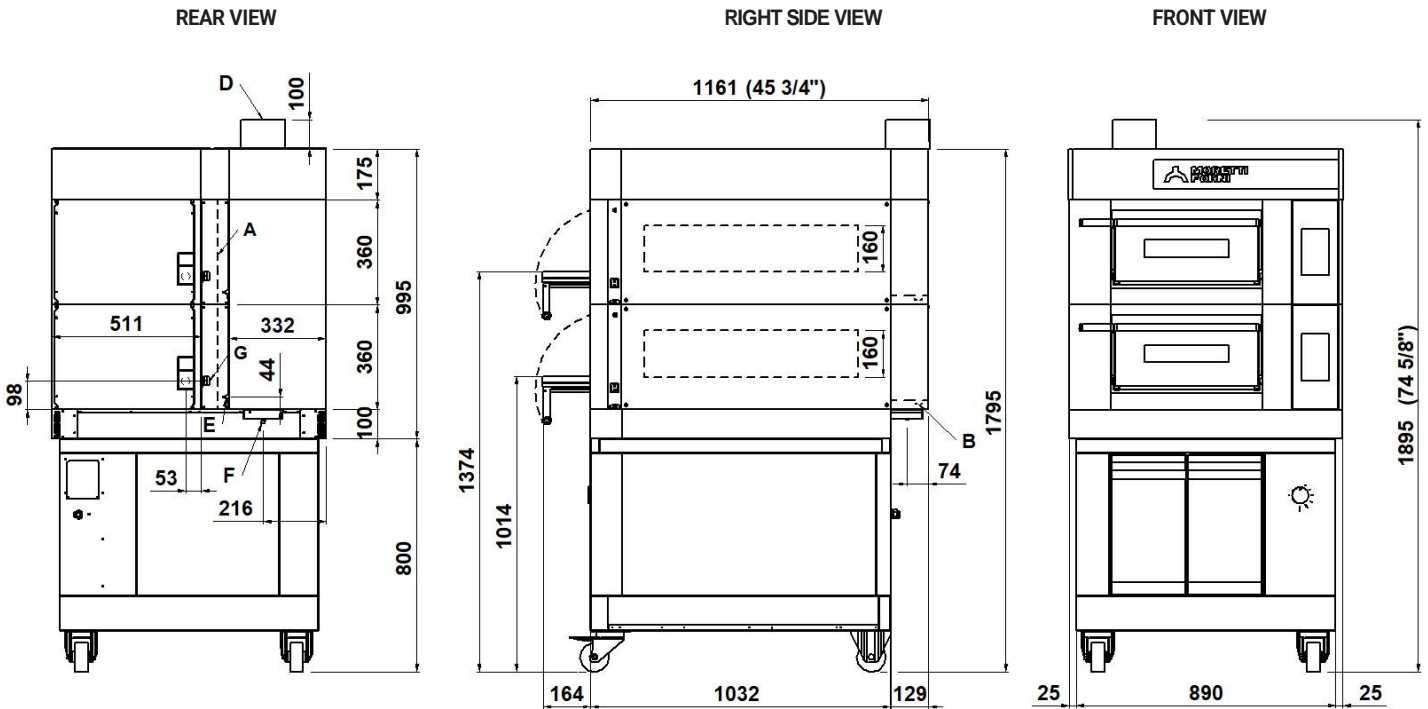

NOTE: The dimensions indicated in the views are in millimetres.

A steamer 1200W (see data sheet)	B 3/4" male steamer water inlet	D Ø150 steam exhaust	E M6 equipotential screws
F Ø12 condensation exhaust	G fairleads		

DIMENSIONS

External height	995mm
External depth	1161mm
External width	942mm
Weight	276kg

TOTAL BAKING CAPACITY

Tray (600x400 mm)	2
Pizza diameter 350mm	4
Pizza diameter 450mm	2

SHIPPING INFORMATION

Packed in wooden crate	
Height	1195mm
Depth	1360mm
Width	1150mm
Weight	(276+60)kg

When combined with stand or prover:	
Max height	1995mm
Max weight	(341+70)kg

FEEDING AND POWER

Standard feeding	
A.C. V400 3N	
Feeding on request	
A.C. V230 3	
Frequency	50/60Hz
Max power	8,8kW
*Average power cons	2,4÷3,2kWh
Connecting cable for each chamber	
type H07RN-F	
5x2,5mm ² (V400 3N)	
4x4mm ² (V230 3)	
Power supply (optional prover)	
A.C. V230 1N 50/60 Hz	
Max power	1,5kW
*Average power cons	0,8kWh
Conn. Cable type H07RN-F	3x1,5mm ²

* This value is subject to variation according to the way in which the equipment is used

NOTE: MORETTI FORNI S.P.A. reserves the right to modify the characteristics of the products illustrated in this publication without prior notice

3 baking chambers height 16 cm
(assembled with prover height 600mm)

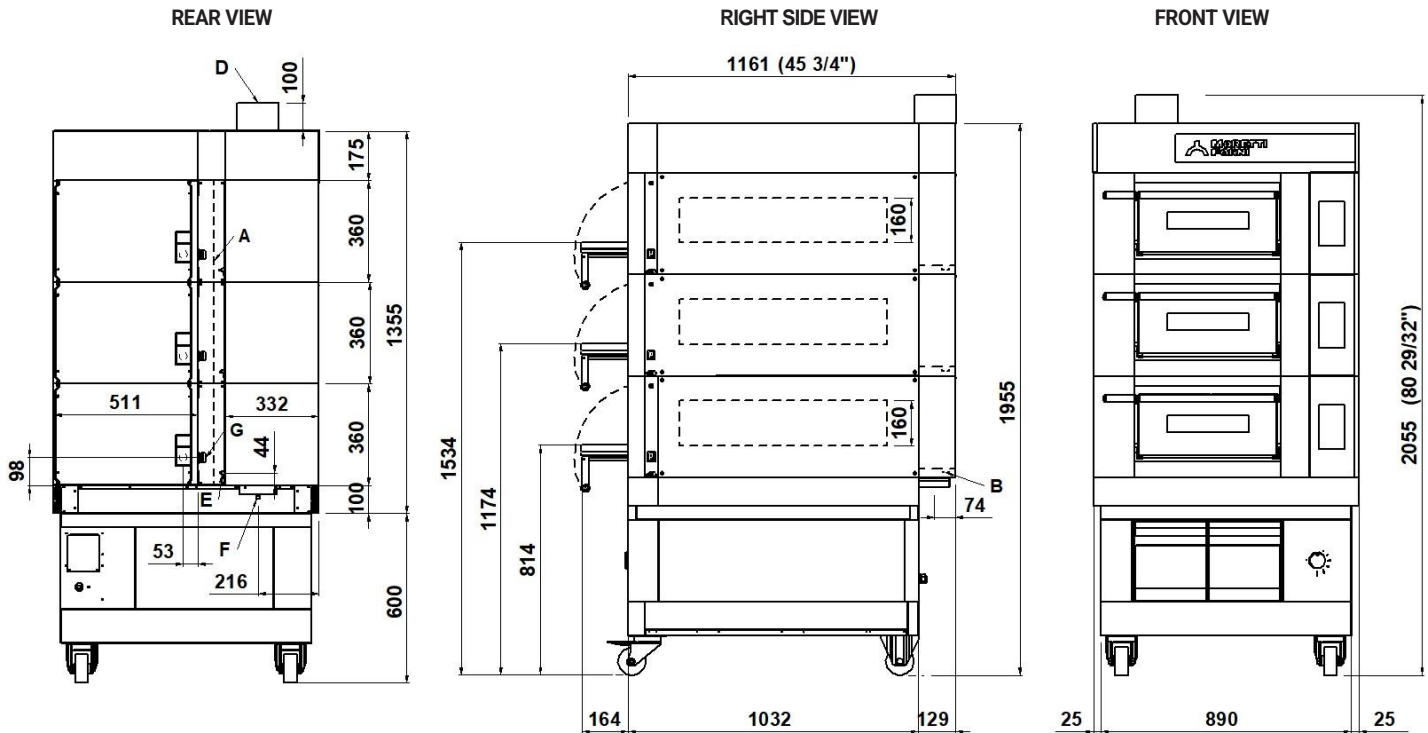

NOTE: The dimensions indicated in the views are in millimetres. *Dimensions refer to the oversized hood.

A steamer 1200W (see data sheet)	B 3/4" male steamer water inlet	D Ø150 steam exhaust	E M6 equipotential screws
F Ø12 condensation exhaust	G fairleads		

DIMENSIONS

External height	1355mm
External depth	1161mm
External width	942mm
Weight	388kg

TOTAL BAKING CAPACITY

Tray (600x400 mm)	3
Pizza diameter 350mm	6
Pizza diameter 450mm	3

SHIPPING INFORMATION

Packed in wooden crate	
Height	1505mm
Depth	1360mm
Width	1150mm
Weight	(388+70)kg

When combined with stand or prover:	
Max height	2155mm
Max weight	(446+80)kg

FEEDING AND POWER

Standard feeding	
A.C. V400 3N	
Feeding on request	
A.C. V230 3	
Frequency	50/60Hz
Max power	13,2kW
*Average power cons	3,6÷4,8kWh
Connecting cable for each chamber	
type H07RN-F	
5x4mm ² (V400 3N)	
4x6mm ² (V230 3)	
Power supply (optional prover)	
A.C. V230 1N 50/60 Hz	
Max power	1,5kW
*Average power cons	0,8kWh
Conn. Cable type H07RN-F	3x1,5mm ²

* This value is subject to variation according to the way in which the equipment is used

NOTE: MORETTI FORNI S.P.A. reserves the right to modify the characteristics of the products illustrated in this publication without prior notice

2 baking chambers height 16+22 cm
(assembled with prover height 800mm)

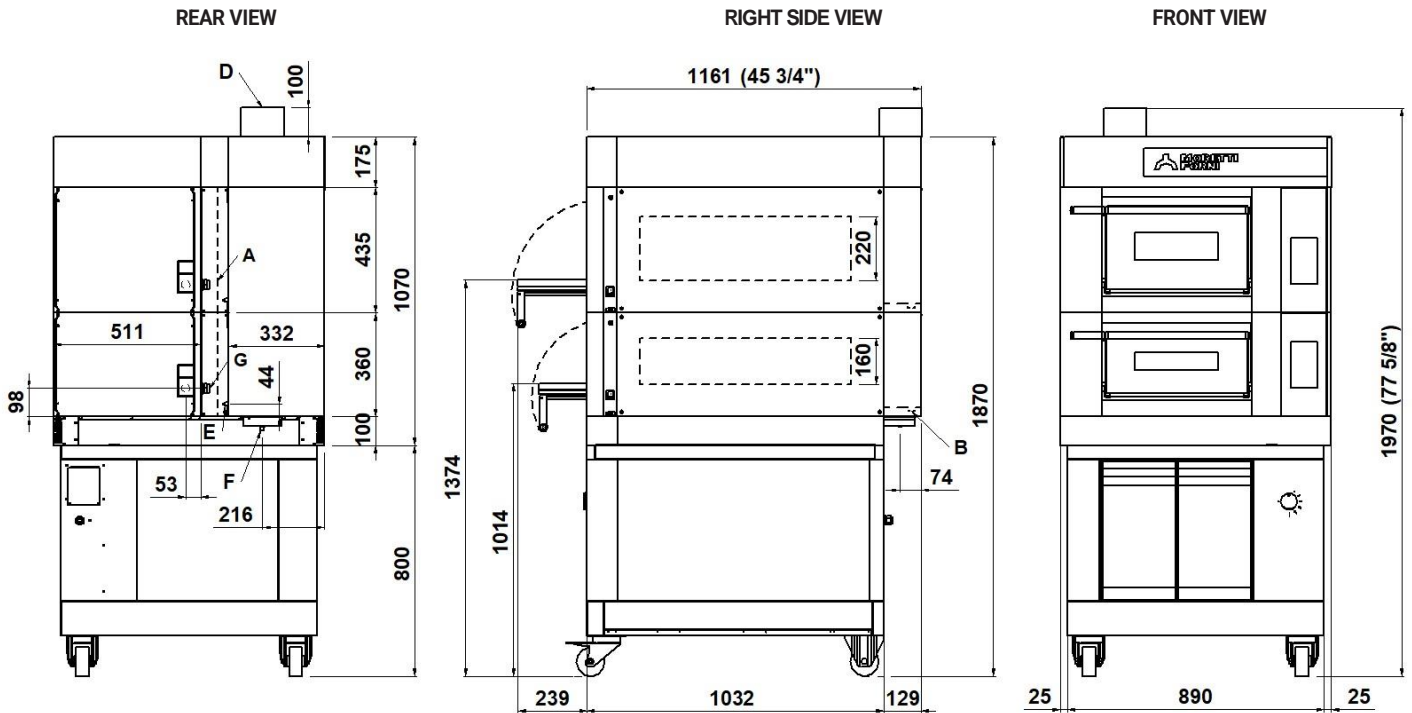

NOTE: The dimensions indicated in the views are in millimetres.

A steamer 1200W (see data sheet)	B 3/4" male steamer water inlet	D Ø150 steam exhaust	E M6 equipotential screws
F Ø12 condensation exhaust	G fairleads		

DIMENSIONS

External height	1070mm
External depth	1161mm
External width	942mm
Weight	284kg

TOTAL BAKING CAPACITY

Tray (600x400 mm)	2
Pizza diameter 350mm	4
Pizza diameter 450mm	2

SHIPPING INFORMATION

Packed in wooden crate	
Height	1270mm
Depth	1360mm
Width	1150mm
Weight	(284+60)kg

When combined with stand or prover:	
Max height	2070mm
Max weight	(349+70)kg

FEEDING AND POWER

Standard feeding	
A.C. V400 3N	
Feeding on request	
A.C. V230 3	
Frequency	50/60Hz
Max power	8,8kW
*Average power cons	2,4÷3,2kWh
Connecting cable for each chamber	
type H07RN-F	
5x2,5mm ² (V400 3N)	
4x4mm ² (V230 3)	
Power supply (optional prover)	
A.C. V230 1N 50/60 Hz	
Max power	1,5kW
*Average power cons	0,8kWh
Conn. Cable type H07RN-F	3x1,5mm ²

* This value is subject to variation according to the way in which the equipment is used
NOTE: MORETTI FORNI S.P.A. reserves the right to modify the characteristics of the products illustrated in this publication without prior notice

3 baking chambers height 16+16+22 cm
(assembled with prover height 600mm)

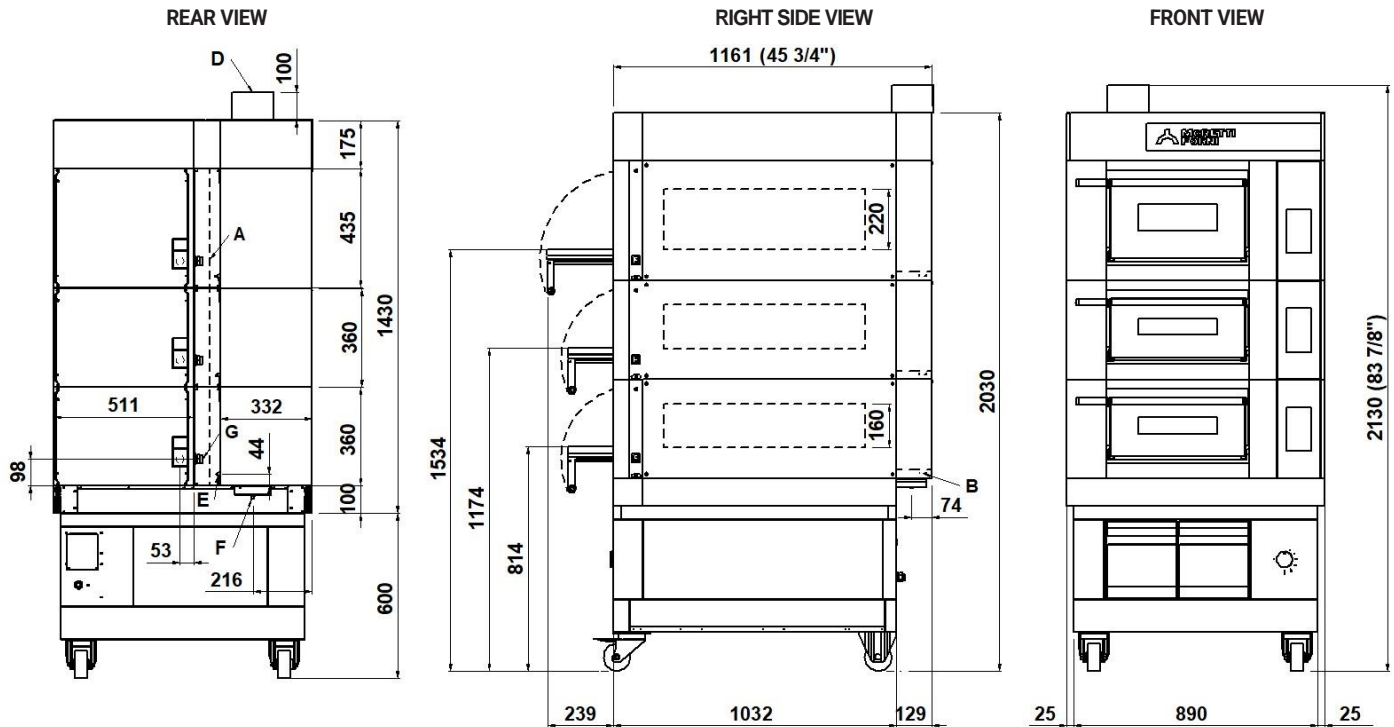

NOTE: The dimensions indicated in the views are in millimetres. *Dimensions refer to the oversized hood.

A steamer 1200W (see data sheet)	B 3/4" male steamer water inlet	D Ø150 steam exhaust	E M6 equipotential screws
F Ø12 condensation exhaust	G fairleads		

DIMENSIONS

External height	1430mm
External depth	1161mm
External width	942mm
Weight	397kg

TOTAL BAKING CAPACITY

Tray (600x400 mm)	3
Pizza diameter 350mm	6
Pizza diameter 450mm	3

SHIPPING INFORMATION

Packed in wooden crate	
Height	1630mm
Depth	1360mm
Width	1150mm
Weight	(397+70)kg

When combined with stand or prover:	
Max height	1995mm
Max weight	(455+80)kg

FEEDING AND POWER

Standard feeding	
A.C. V400 3N	
Feeding on request	
A.C. V230 3	
Frequency	50/60Hz
Max power	13,2kW
*Average power cons	3,6÷4,8kWh
Connecting cable for each chamber	
type H07RN-F	
5x4mm ² (V400 3N)	
4x6mm ² (V230 3)	
Power supply (optional prover)	
A.C. V230 1N 50/60 Hz	
Max power	1,5kW
*Average power cons	0,8kWh
Conn. Cable type H07RN-F	3x1,5mm ²

* This value is subject to variation according to the way in which the equipment is used

NOTE: MORETTI FORNI S.P.A. reserves the right to modify the characteristics of the products illustrated in this publication without prior notice

X50

TECHNICAL DATA

SHIPPING INFORMATION H16		X50E_1_16	X50E_2_16	X50E_3_16
Packed in wooden crate	Height	835mm	1195mm	1555mm
	Weight	(163+50)kg	(276+60)kg	(388+70)kg
When combined with prover or Stand	Max. height.	1785mm	1995mm	2155mm
	Max. weight.	(228+60)kg	(341+70)kg	(446+80)kg
SHIPPING INFORMATION H22		X50E_1_22	X50E_2_22	X50E_3_22
Packed in wooden crate	Height	910mm	1345mm	1780mm
	Weight	(172+50)kg	(293+60)kg	(414+70)kg
When combined with prover or Stand	Max. height.	1860mm	2295mm	2380mm
	Max. weight	(237+60)kg	(358+70)kg	(472+80)kg

* This value is subject to variation according to the way in which the equipment is used

NOTE: MORETTI FORNI S.P.A. reserves the right to modify the characteristics of the products illustrated in this publication without prior notice



Modular electric deck oven 2 decks composition

serieX is the first oven in the market equipped with **Any Chef™ Technology**, able to autonomously set the **perfect baking cycle for any kind of product**.

Ideal for **Any Business**, serieX grants a substantial saving in h/operator costs. Specific for **Any Product**, can fit **in Any Place**, thanks to energy consumption reduced by 45%.

The **intuitive interface** makes serieX suitable for **Any Chef**: everyone can be a baking master of **pizza, bread, pastry and gastronomy**. By choosing your recipe parameters, serieX will automatically set the temperature and baking time, and the user-friendly **TFT Touch display will show the best area to place the product**.

serieX takes the oven to another level: not only a tool, but also a **precise partner to which delegate part of your daily work**.



OPERATION

- Heated by highly performing armoured heating elements, working independently in each baking area
- SmartDeck™: thanks to the sensor system in each baking area, the heat is supplied only where needed, automatically regulating the heating elements power according to product type and quantity. The display always suggests the best area to use, allowing the right surface rotation and utilising heat at its best. The system determines the workload and automatically sets Auto EcoStandby™ for pauses or Auto PowerBooster™ for work peaks
- Adaptive BakingTime™ thanks to the software algorithm, the baking time adapts depending both on the heat quantity detected and on the product in the baking area
- Pre-set cycles with variable phases specific for bread, pastry and gastronomy products
- UI with intuitive sliders that allow to easily customise the baking result. Mapping is optimised for every product
- AdaptivePower® Technology: power management with P.I.D. permits automatic energy regulation based on the quantity of product baked
- DualPower+™: ceiling / floor temperature and power can be managed separately and simultaneously
- Continuous temperature detection inside the baking chamber through thermocouple
- Optimal heat balancing since the first baking
- Automatic pyrolytic cleaning program, PowerCleaning™
- Self-limited temperature at 400°C
- Vapour discharge by programmable steam valve

CONSTRUCTION

- Front structure made of bent stainless steel
- Side panels in painted metal sheet
- Frontless hood
- Stainless steel door with external fairing for better insulation and safety
- Brushed stainless steel handles made with antiseptic finish
- Refractory brick baking surface
- Side and top internal structure made of aluminised steel
- Internal rear-view mirrors made of reflecting steel suitable for high temperatures (not applied for decks equipped with steamer)
- Oriented double LED light, placed in a protected position
- Heat insulation CoolAround® Technology

INTERNAL BAKING CHAMBER DIMENSIONS

Internal height	160mm
Internal depth	735mm
Internal width	475mm
Baking surface	0,35m ²

ACCESSORIES

- Prover with wheels height 600, 800mm
- Stand with wheels height 400, 600, 800, 950, 1050mm
- Additional tray holder guides for prover and stand
- Programmable steamer with steam regulation
- Door opening upwards
- Multipoint core probe
- Self-condensing hood
- Kit support feet for countertop installation H=15mm
- Remote-Master® Technology

STANDARD EQUIPMENT

- Multilanguage, antiglare, colour display TFT Touch 7" IPS
- Customisable baking cycles according to your dough
- 4 different working modes: Bake, Regenerate, Prebake, Refining®
- Auto EcoStandby™ for work pauses
- Auto PowerBooster™ for work peaks
- Oven front/rear power balance DeltaPower+™
- ReadyToGo Timer, optimised switch on based on baking time set. Two daily start and stop programmable.
- FlexLoad™ automatically identifies where the work load is activating the heating elements in the corresponding area
- Self-diagnosis with error message on display
- Multi timer
- Maximum temperature independent safety device
- USB port and WiFi module for software update
- SmartBaking app

TOP VIEW

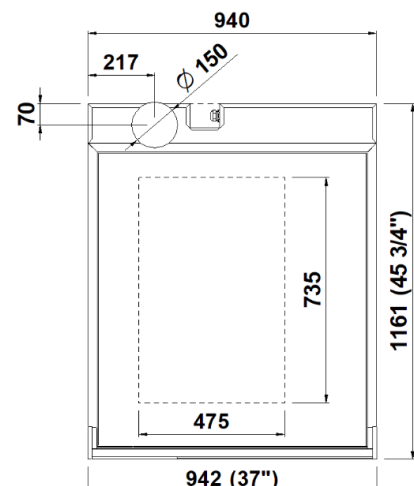

1 baking chamber height 16cm
(assembled with stand height 950mm)

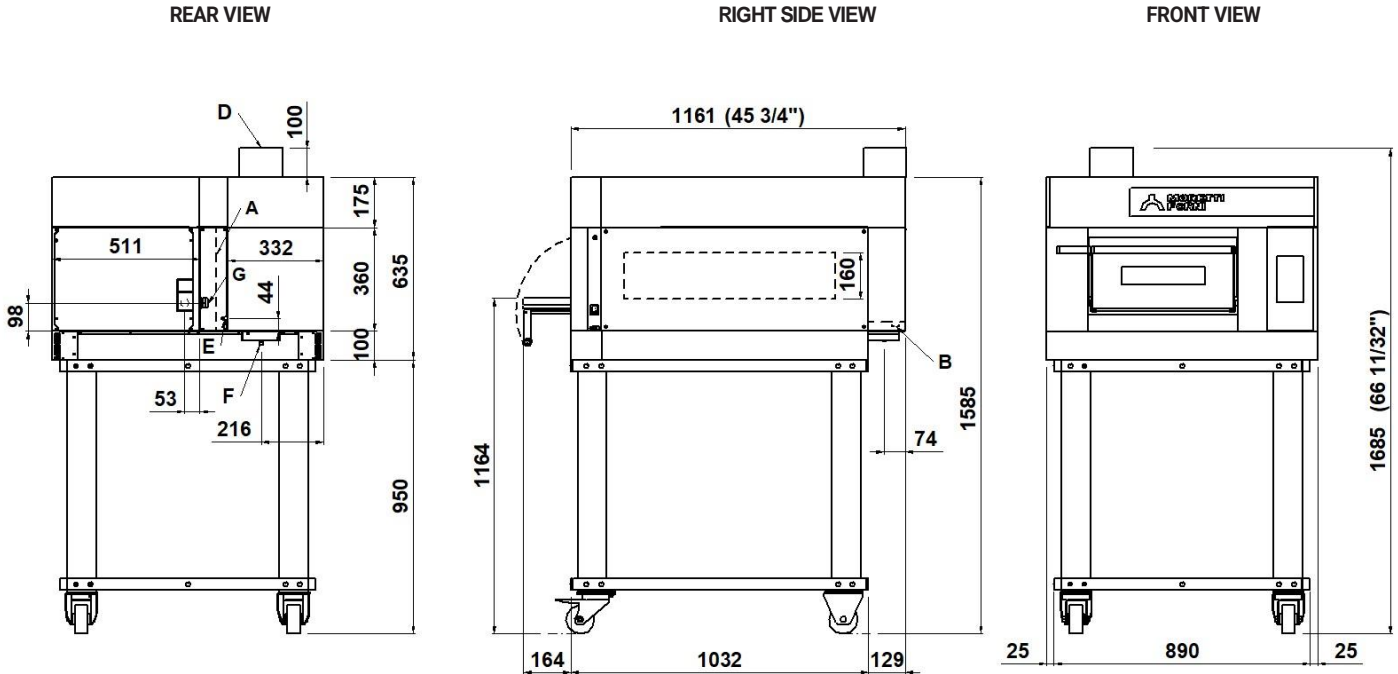

NOTE: The dimensions indicated in the views are in millimetres.

A steamer 1200W (see data sheet)	B 3/4" male steamer water inlet	D Ø150 steam exhaust	E M6 equipotential screws
F Ø12 condensation exhaust	G fairleads		

DIMENSIONS

External height	635mm
External depth	1161mm
External width	942mm
Weight	163kg

SHIPPING INFORMATION

Packed in wooden crate	
Height	835mm
Depth	1360mm
Width	1150mm
Weight	(163+50)kg

FEEDING AND POWER

Standard feeding	
A.C. V400 3N	
Feeding on request	
A.C. V230 3	
Frequency	50/60Hz
Max power	4,4kW
*Average power cons	1,2÷1,6kWh
Connecting cable for each chamber	
type H07RN-F	
5x2,5mm ² (V400 3N)	
4x4mm ² (V230 3)	
Power supply (optional prover)	
A.C. V230 1N 50/60 Hz	
Max power	1,5kW
*Average power cons	0,8kWh
Conn. Cable type H07RN-F	3x1,5mm ²

TOTAL BAKING CAPACITY

Tray (600x400 mm)	1	When combined with stand or prover:	
Pizza diameter 350mm	2	Max height	1785mm
Pizza diameter 450mm	1	Max weight	(228+60)kg

* This value is subject to variation according to the way in which the equipment is used

NOTE: MORETTI FORNI S.P.A. reserves the right to modify the characteristics of the products illustrated in this publication without prior notice

2 baking chambers height 16cm
(assembled with prover height 800mm)

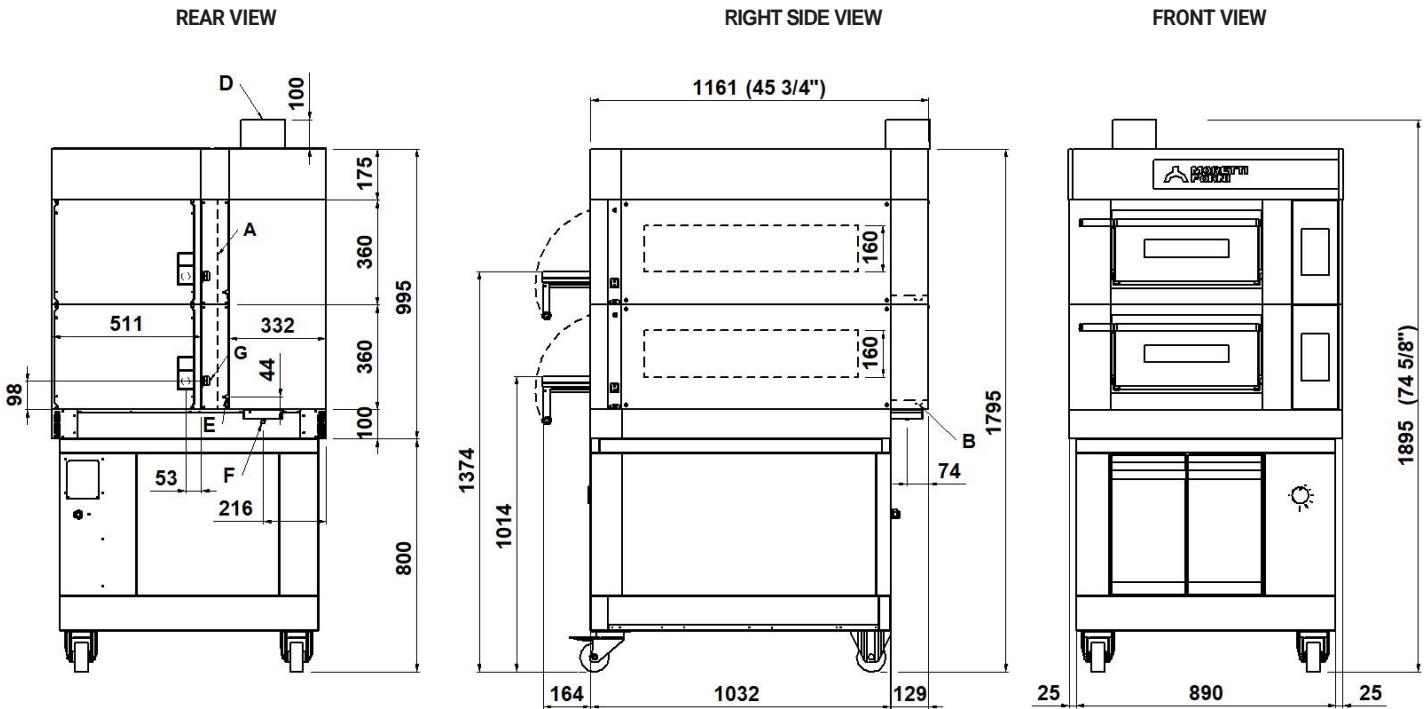

NOTE: The dimensions indicated in the views are in millimetres.

A steamer 1200W (see data sheet)	B 3/4" male steamer water inlet	D Ø150 steam exhaust	E M6 equipotential screws
F Ø12 condensation exhaust	G fairleads		

DIMENSIONS

External height	995mm
External depth	1161mm
External width	942mm
Weight	276kg

TOTAL BAKING CAPACITY

Tray (600x400 mm)	2
Pizza diameter 350mm	4
Pizza diameter 450mm	2

SHIPPING INFORMATION

Packed in wooden crate	
Height	1195mm
Depth	1360mm
Width	1150mm
Weight	(276+60)kg

When combined with stand or prover:	
Max height	1995mm
Max weight	(341+70)kg

FEEDING AND POWER

Standard feeding	
A.C. V400 3N	
Feeding on request	
A.C. V230 3	
Frequency	50/60Hz
Max power	8,8kW
*Average power cons	2,4÷3,2kWh
Connecting cable for each chamber	
type H07RN-F	
5x2,5mm ² (V400 3N)	
4x4mm ² (V230 3)	
Power supply (optional prover)	
A.C. V230 1N 50/60 Hz	
Max power	1,5kW
*Average power cons	0,8kWh
Conn. Cable type H07RN-F	3x1,5mm ²

* This value is subject to variation according to the way in which the equipment is used

NOTE: MORETTI FORNI S.P.A. reserves the right to modify the characteristics of the products illustrated in this publication without prior notice

3 baking chambers height 16 cm
(assembled with prover height 600mm)

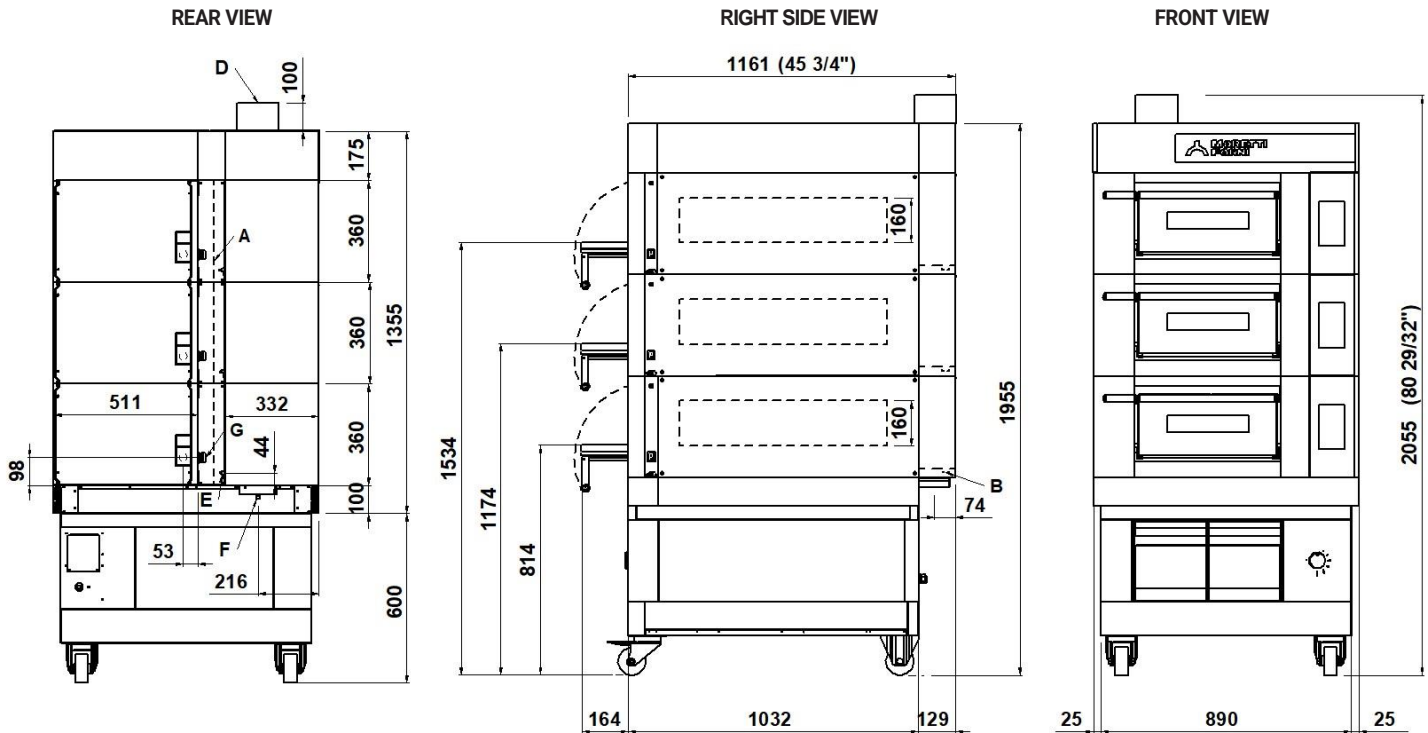

NOTE: The dimensions indicated in the views are in millimetres. *Dimensions refer to the oversized hood.

A steamer 1200W (see data sheet)	B 3/4" male steamer water inlet	D Ø150 steam exhaust	E M6 equipotential screws
F Ø12 condensation exhaust	G fairleads		

DIMENSIONS

External height	1355mm
External depth	1161mm
External width	942mm
Weight	388kg

TOTAL BAKING CAPACITY

Tray (600x400 mm)	3
Pizza diameter 350mm	6
Pizza diameter 450mm	3

SHIPPING INFORMATION

Packed in wooden crate	
Height	1505mm
Depth	1360mm
Width	1150mm
Weight	(388+70)kg

When combined with stand or prover:	
Max height	2155mm
Max weight	(446+80)kg

FEEDING AND POWER

Standard feeding	
A.C. V400 3N	
Feeding on request	
A.C. V230 3	
Frequency	50/60Hz
Max power	13,2kW
*Average power cons	3,6÷4,8kWh
Connecting cable for each chamber	
type H07RN-F	
5x4mm ² (V400 3N)	
4x6mm ² (V230 3)	
Power supply (optional prover)	
A.C. V230 1N 50/60 Hz	
Max power	1,5kW
*Average power cons	0,8kWh
Conn. Cable type H07RN-F	3x1,5mm ²

* This value is subject to variation according to the way in which the equipment is used

NOTE: MORETTI FORNI S.P.A. reserves the right to modify the characteristics of the products illustrated in this publication without prior notice

2 baking chambers height 16+22 cm
(assembled with prover height 800mm)

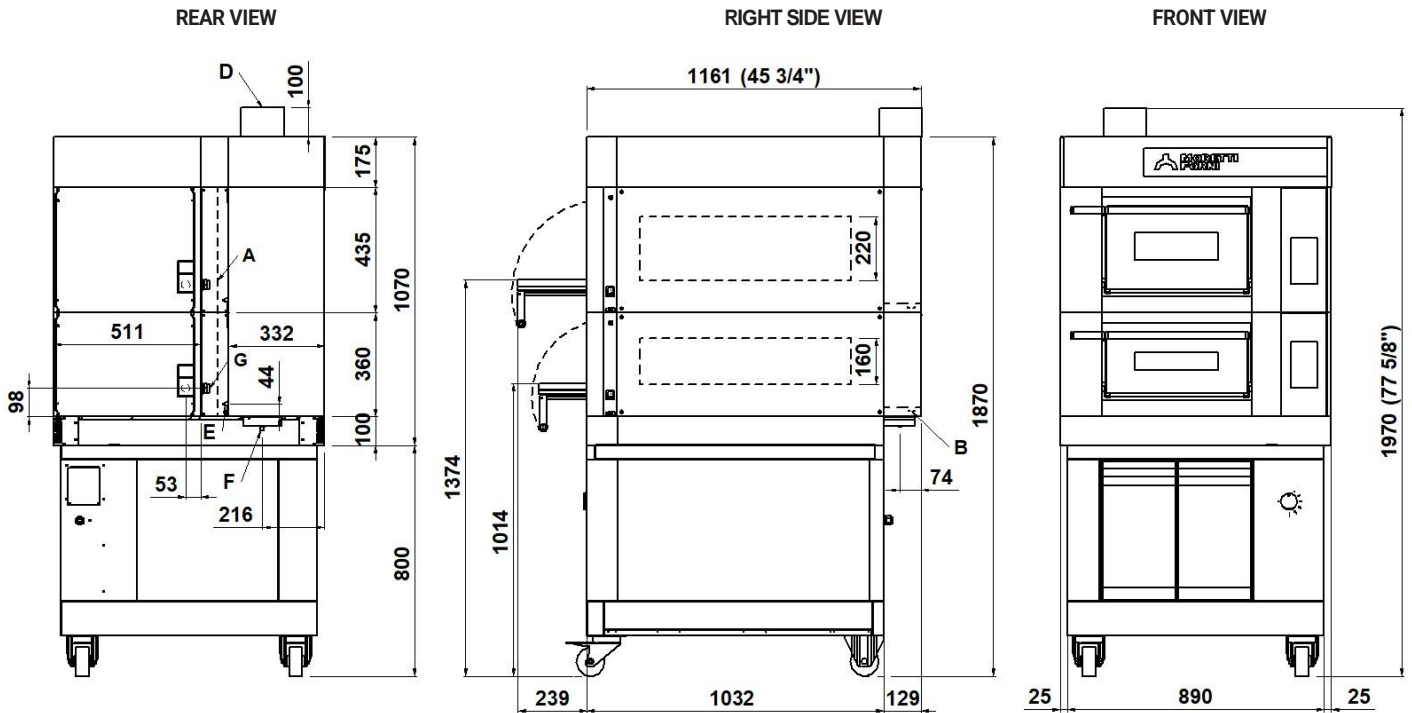

NOTE: The dimensions indicated in the views are in millimetres.

A steamer 1200W (see data sheet)	B 3/4" male steamer water inlet	D Ø150 steam exhaust	E M6 equipotential screws
F Ø12 condensation exhaust	G fairleads		

DIMENSIONS

External height	1070mm
External depth	1161mm
External width	942mm
Weight	284kg

TOTAL BAKING CAPACITY

Tray (600x400 mm)	2
Pizza diameter 350mm	4
Pizza diameter 450mm	2

SHIPPING INFORMATION

Packed in wooden crate	
Height	1270mm
Depth	1360mm
Width	1150mm
Weight	(284+60)kg

When combined with stand or prover:	
Max height	2070mm
Max weight	(349+70)kg

FEEDING AND POWER

Standard feeding	
A.C. V400 3N	
Feeding on request	
A.C. V230 3	
Frequency	50/60Hz
Max power	8,8kW
*Average power cons	2,4÷3,2kWh
Connecting cable for each chamber	
type H07RN-F	
5x2,5mm ² (V400 3N)	
4x4mm ² (V230 3)	
Power supply (optional prover)	
A.C. V230 1N 50/60 Hz	
Max power	1,5kW
*Average power cons	0,8kWh
Conn. Cable type H07RN-F	3x1,5mm ²

* This value is subject to variation according to the way in which the equipment is used
NOTE: MORETTI FORNI S.P.A. reserves the right to modify the characteristics of the products illustrated in this publication without prior notice

3 baking chambers height 16+16+22 cm
(assembled with prover height 600mm)

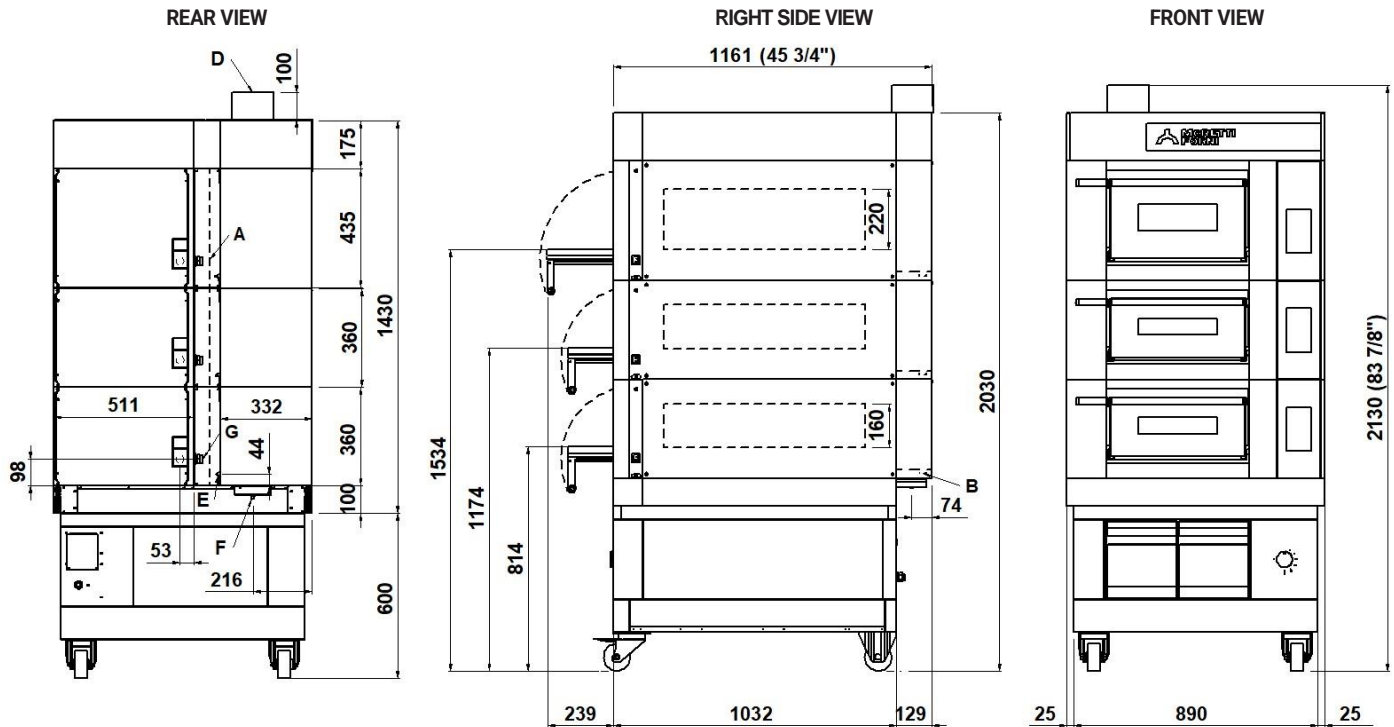

NOTE: The dimensions indicated in the views are in millimetres. *Dimensions refer to the oversized hood.

A steamer 1200W (see data sheet)	B 3/4" male steamer water inlet	D Ø150 steam exhaust	E M6 equipotential screws
F Ø12 condensation exhaust	G fairleads		

DIMENSIONS

External height	1430mm
External depth	1161mm
External width	942mm
Weight	397kg

TOTAL BAKING CAPACITY

Tray (600x400 mm)	3
Pizza diameter 350mm	6
Pizza diameter 450mm	3

SHIPPING INFORMATION

Packed in wooden crate	
Height	1630mm
Depth	1360mm
Width	1150mm
Weight	(397+70)kg

When combined with stand or prover:	
Max height	1995mm
Max weight	(455+80)kg

FEEDING AND POWER

Standard feeding	
A.C. V400 3N	
Feeding on request	
A.C. V230 3	
Frequency	50/60Hz
Max power	13,2kW
*Average power cons	3,6÷4,8kWh
Connecting cable for each chamber	
type H07RN-F	
5x4mm ² (V400 3N)	
4x6mm ² (V230 3)	
Power supply (optional prover)	
A.C. V230 1N 50/60 Hz	
Max power	1,5kW
*Average power cons	0,8kWh
Conn. Cable type H07RN-F	3x1,5mm ²

* This value is subject to variation according to the way in which the equipment is used

NOTE: MORETTI FORNI S.P.A. reserves the right to modify the characteristics of the products illustrated in this publication without prior notice

X50
TECHNICAL DATA

SHIPPING INFORMATION H16		X50E_1_16	X50E_2_16	X50E_3_16
Packed in wooden crate	Height	835mm	1195mm	1555mm
	Weight	(163+50)kg	(276+60)kg	(388+70)kg
When combined with prover or Stand	Max. height.	1785mm	1995mm	2155mm
	Max. weight.	(228+60)kg	(341+70)kg	(446+80)kg
SHIPPING INFORMATION H22		X50E_1_22	X50E_2_22	X50E_3_22
Packed in wooden crate	Height	910mm	1345mm	1780mm
	Weight	(172+50)kg	(293+60)kg	(414+70)kg
When combined with prover or Stand	Max. height.	1860mm	2295mm	2380mm
	Max. weight	(237+60)kg	(358+70)kg	(472+80)kg

* This value is subject to variation according to the way in which the equipment is used
NOTE: MORETTI FORNI S.P.A. reserves the right to modify the characteristics of the products illustrated in this publication without prior notice



Modular electric deck oven 2 decks composition

serieX is the first oven in the market equipped with **Any Chef™ Technology**, able to autonomously set the **perfect baking cycle for any kind of product**.

Ideal for **Any Business**, serieX grants a substantial saving in h/operator costs. Specific for **Any Product**, can fit **in Any Place**, thanks to energy consumption reduced by 45%.

The **intuitive interface** makes serieX suitable for **Any Chef**: everyone can be a baking master of **pizza, bread, pastry and gastronomy**. By choosing your recipe parameters, serieX will automatically set the temperature and baking time, and the user-friendly **TFT Touch display will show the best area to place the product**.

serieX takes the oven to another level: not only a tool, but also a **precise partner to which delegate part of your daily work**.



OPERATION

- Heated by highly performing armoured heating elements, working independently in each baking area
- SmartDeck™: thanks to the sensor system in each baking area, the heat is supplied only where needed, automatically regulating the heating elements power according to product type and quantity. The display always suggests the best area to use, allowing the right surface rotation and utilising heat at its best. The system determines the workload and automatically sets Auto EcoStandby™ for pauses or Auto PowerBooster™ for work peaks
- Adaptive BakingTime™ thanks to the software algorithm, the baking time adapts depending both on the heat quantity detected and on the product in the baking area
- Pre-set cycles with variable phases specific for bread, pastry and gastronomy products
- UI with intuitive sliders that allow to easily customise the baking result. Mapping is optimised for every product
- AdaptivePower® Technology: power management with P.I.D. permits automatic energy regulation based on the quantity of product baked
- DualPower+™: ceiling / floor temperature and power can be managed separately and simultaneously
- Continuous temperature detection inside the baking chamber through thermocouple
- Optimal heat balancing since the first baking
- Automatic pyrolytic cleaning program, PowerCleaning™
- Self-limited temperature at 400°C
- Vapour discharge by programmable steam valve

CONSTRUCTION

- Front structure made of bent stainless steel
- Side panels in painted metal sheet
- Frontless hood
- Stainless steel door with external fairing for better insulation and safety
- Brushed stainless steel handles made with antiseptic finish
- Refractory brick baking surface
- Side and top internal structure made of aluminised steel
- Internal rear-view mirrors made of reflecting steel suitable for high temperatures (not applied for decks equipped with steamer)
- Oriented double LED light, placed in a protected position
- Heat insulation CoolAround® Technology

INTERNAL BAKING CHAMBER DIMENSIONS

Internal height	160mm
Internal depth	735mm
Internal width	475mm
Baking surface	0,35m ²

ACCESSORIES

- Prover with wheels height 600, 800mm
- Stand with wheels height 400, 600, 800, 950, 1050mm
- Additional tray holder guides for prover and stand
- Programmable steamer with steam regulation
- Door opening upwards
- Multipoint core probe
- Self-condensing hood
- Kit support feet for countertop installation H=15mm
- Remote-Master® Technology

STANDARD EQUIPMENT

- Multilanguage, antiglare, colour display TFT Touch 7" IPS
- Customisable baking cycles according to your dough
- 4 different working modes: Bake, Regenerate, Prebake, Refining®
- Auto EcoStandby™ for work pauses
- Auto PowerBooster™ for work peaks
- Oven front/rear power balance DeltaPower+™
- ReadyToGo Timer, optimised switch on based on baking time set. Two daily start and stop programmable.
- FlexLoad™ automatically identifies where the work load is activating the heating elements in the corresponding area
- Self-diagnosis with error message on display
- Multi timer
- Maximum temperature independent safety device
- USB port and WiFi module for software update
- SmartBaking app

TOP VIEW

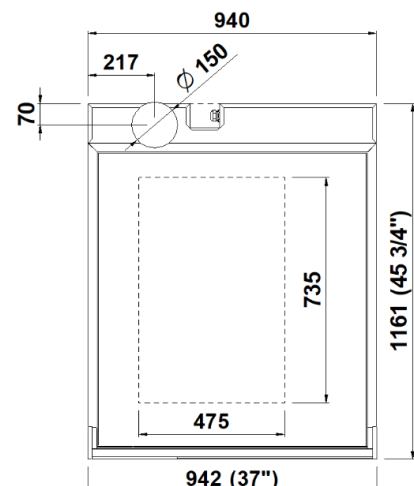

1 baking chamber height 16cm
(assembled with stand height 950mm)

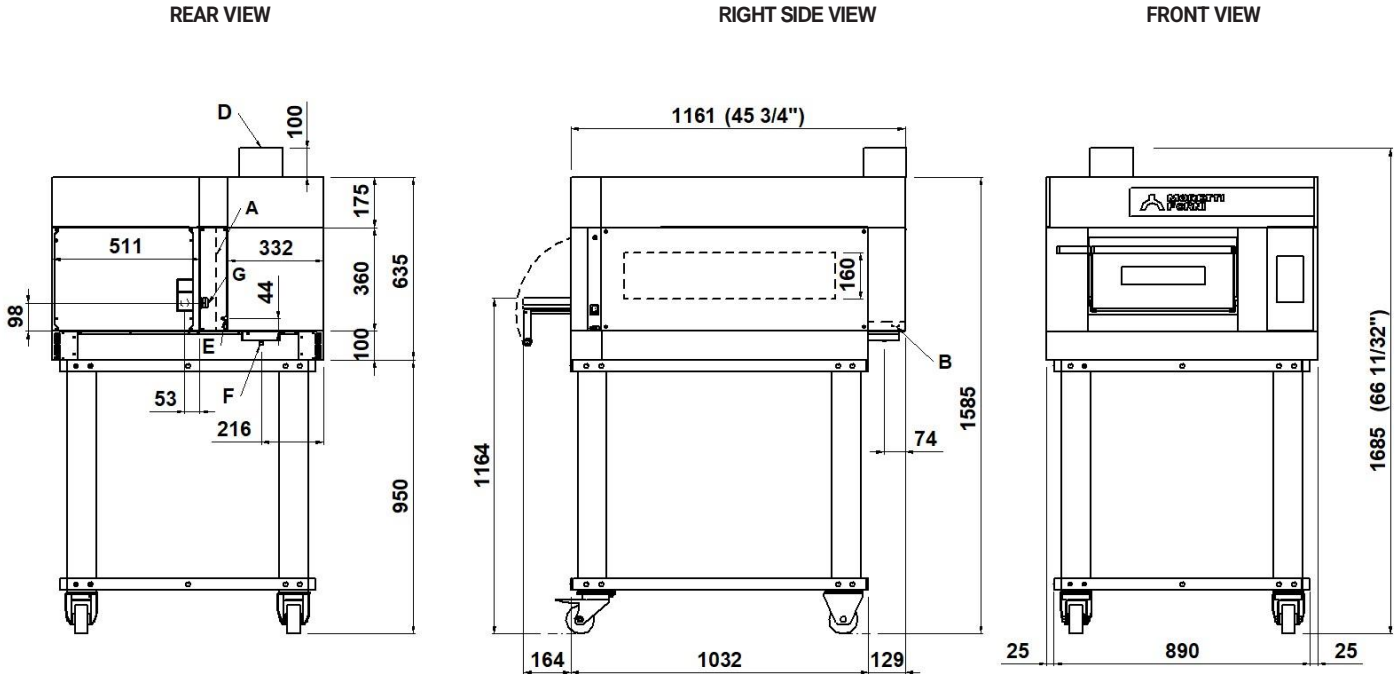

NOTE: The dimensions indicated in the views are in millimetres.

A steamer 1200W (see data sheet)	B 3/4" male steamer water inlet	D Ø150 steam exhaust	E M6 equipotential screws
F Ø12 condensation exhaust	G fairleads		

DIMENSIONS

External height	635mm
External depth	1161mm
External width	942mm
Weight	163kg

SHIPPING INFORMATION

Packed in wooden crate	
Height	835mm
Depth	1360mm
Width	1150mm
Weight	(163+50)kg

FEEDING AND POWER

Standard feeding	
A.C. V400 3N	
Feeding on request	
A.C. V230 3	
Frequency	50/60Hz
Max power	4,4kW
*Average power cons	1,2÷1,6kWh
Connecting cable for each chamber	
type H07RN-F	
5x2,5mm ² (V400 3N)	
4x4mm ² (V230 3)	
Power supply (optional prover)	
A.C. V230 1N 50/60 Hz	
Max power	1,5kW
*Average power cons	0,8kWh
Conn. Cable type H07RN-F	3x1,5mm ²

TOTAL BAKING CAPACITY

Tray (600x400 mm)	1	When combined with stand or prover:	
Pizza diameter 350mm	2	Max height	1785mm
Pizza diameter 450mm	1	Max weight	(228+60)kg

* This value is subject to variation according to the way in which the equipment is used

NOTE: MORETTI FORNI S.P.A. reserves the right to modify the characteristics of the products illustrated in this publication without prior notice

2 baking chambers height 16cm
(assembled with prover height 800mm)

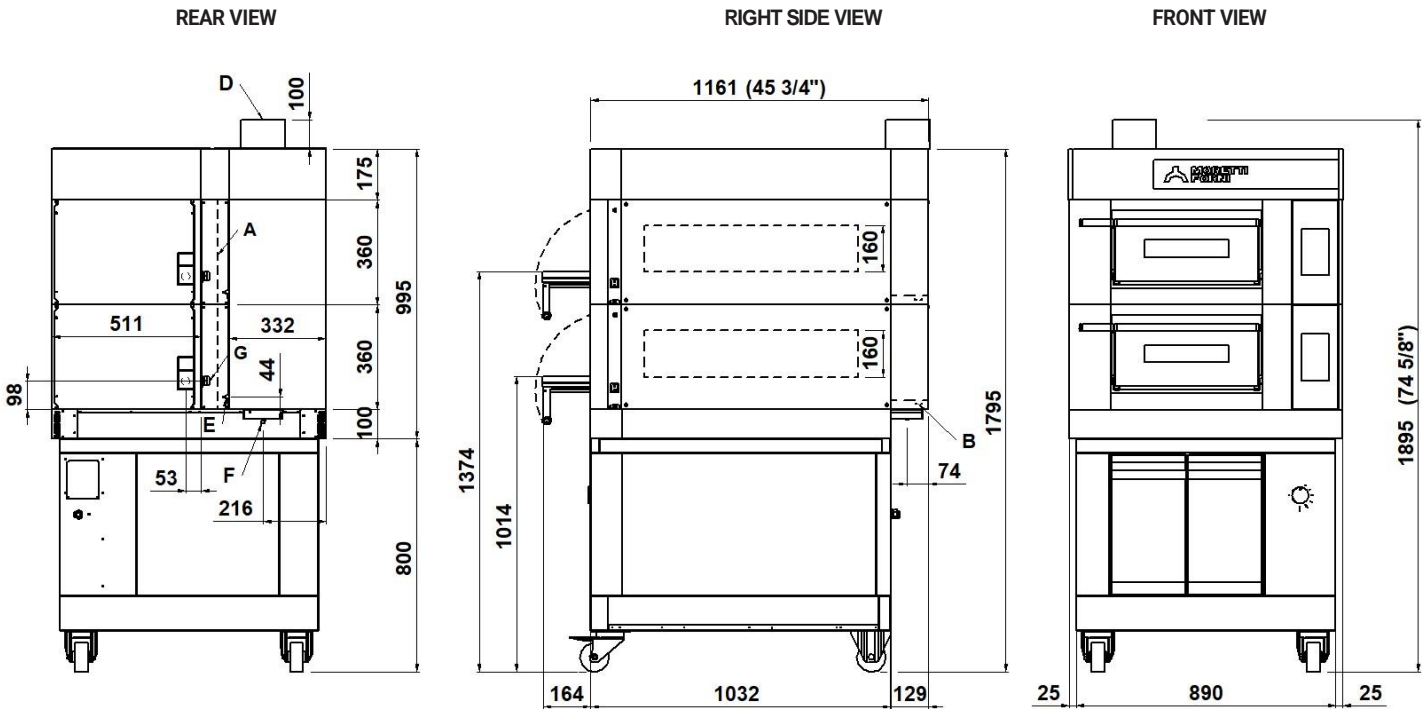

NOTE: The dimensions indicated in the views are in millimetres.

A steamer 1200W (see data sheet)	B 3/4" male steamer water inlet	D Ø150 steam exhaust	E M6 equipotential screws
F Ø12 condensation exhaust	G fairleads		

DIMENSIONS

External height	995mm
External depth	1161mm
External width	942mm
Weight	276kg

TOTAL BAKING CAPACITY

Tray (600x400 mm)	2
Pizza diameter 350mm	4
Pizza diameter 450mm	2

SHIPPING INFORMATION

Packed in wooden crate	
Height	1195mm
Depth	1360mm
Width	1150mm
Weight	(276+60)kg

When combined with stand or prover:	
Max height	1995mm
Max weight	(341+70)kg

FEEDING AND POWER

Standard feeding	
A.C. V400 3N	
Feeding on request	
A.C. V230 3	
Frequency	50/60Hz
Max power	8,8kW
*Average power cons	2,4÷3,2kWh
Connecting cable for each chamber	
type H07RN-F	
5x2,5mm ² (V400 3N)	
4x4mm ² (V230 3)	
Power supply (optional prover)	
A.C. V230 1N 50/60 Hz	
Max power	1,5kW
*Average power cons	0,8kWh
Conn. Cable type H07RN-F	3x1,5mm ²

* This value is subject to variation according to the way in which the equipment is used

NOTE: MORETTI FORNI S.P.A. reserves the right to modify the characteristics of the products illustrated in this publication without prior notice

3 baking chambers height 16 cm
(assembled with prover height 600mm)

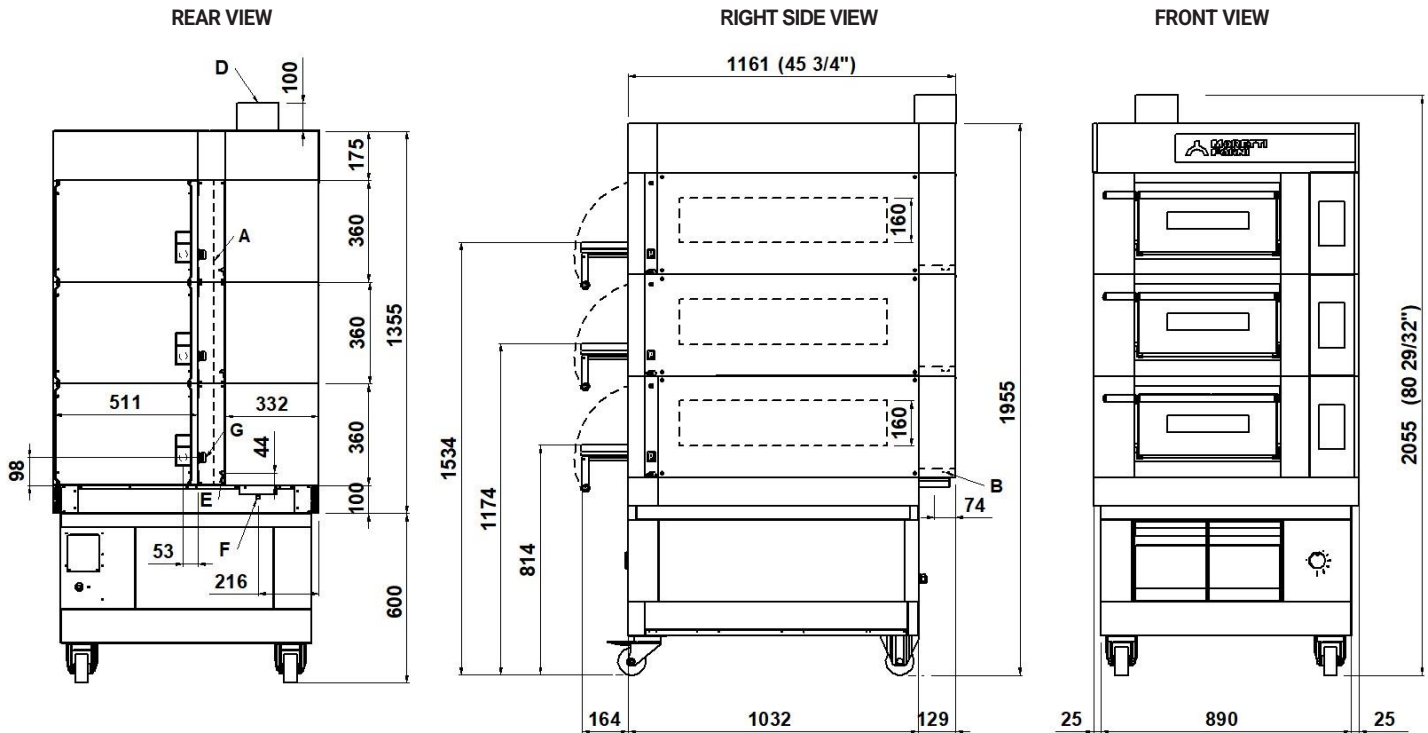

NOTE: The dimensions indicated in the views are in millimetres. *Dimensions refer to the oversized hood.

A steamer 1200W (see data sheet)	B 3/4" male steamer water inlet	D Ø150 steam exhaust	E M6 equipotential screws
F Ø12 condensation exhaust	G fairleads		

DIMENSIONS

External height	1355mm
External depth	1161mm
External width	942mm
Weight	388kg

TOTAL BAKING CAPACITY

Tray (600x400 mm)	3
Pizza diameter 350mm	6
Pizza diameter 450mm	3

SHIPPING INFORMATION

Packed in wooden crate	
Height	1505mm
Depth	1360mm
Width	1150mm
Weight	(388+70)kg

When combined with stand or prover:	
Max height	2155mm
Max weight	(446+80)kg

FEEDING AND POWER

Standard feeding	
A.C. V400 3N	
Feeding on request	
A.C. V230 3	
Frequency	50/60Hz
Max power	13,2kW
*Average power cons	3,6÷4,8kWh
Connecting cable for each chamber	
type H07RN-F	
5x4mm ² (V400 3N)	
4x6mm ² (V230 3)	
Power supply (optional prover)	
A.C. V230 1N 50/60 Hz	
Max power	1,5kW
*Average power cons	0,8kWh
Conn. Cable type H07RN-F	3x1,5mm ²

* This value is subject to variation according to the way in which the equipment is used

NOTE: MORETTI FORNI S.P.A. reserves the right to modify the characteristics of the products illustrated in this publication without prior notice

2 baking chambers height 16+22 cm
(assembled with prover height 800mm)

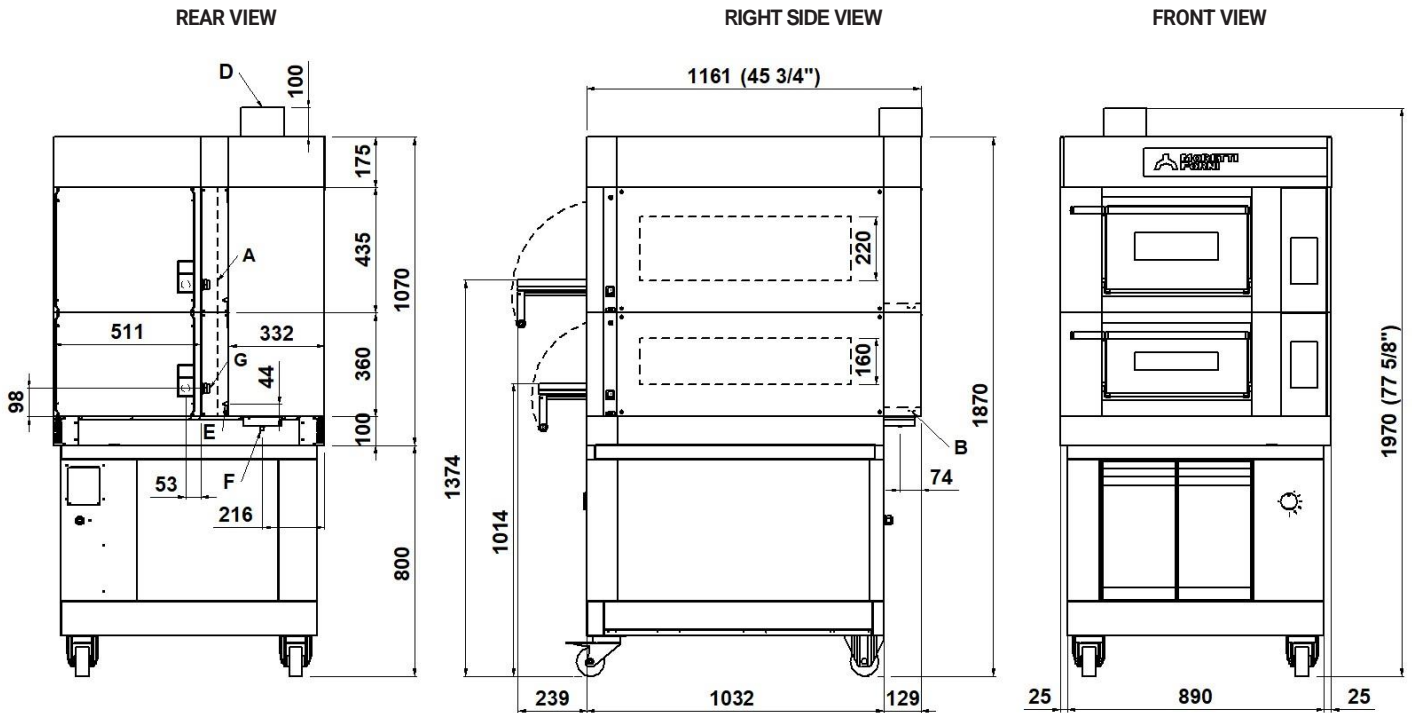

NOTE: The dimensions indicated in the views are in millimetres.

A steamer 1200W (see data sheet)	B 3/4" male steamer water inlet	D Ø150 steam exhaust	E M6 equipotential screws
F Ø12 condensation exhaust	G fairleads		

DIMENSIONS

External height	1070mm
External depth	1161mm
External width	942mm
Weight	284kg

TOTAL BAKING CAPACITY

Tray (600x400 mm)	2
Pizza diameter 350mm	4
Pizza diameter 450mm	2

SHIPPING INFORMATION

Packed in wooden crate	
Height	1270mm
Depth	1360mm
Width	1150mm
Weight	(284+60)kg

When combined with stand or prover:	
Max height	2070mm
Max weight	(349+70)kg

FEEDING AND POWER

Standard feeding	
A.C. V400 3N	
Feeding on request	
A.C. V230 3	
Frequency	50/60Hz
Max power	8,8kW
*Average power cons	2,4÷3,2kWh
Connecting cable for each chamber	
type H07RN-F	
5x2,5mm ² (V400 3N)	
4x4mm ² (V230 3)	
Power supply (optional prover)	
A.C. V230 1N 50/60 Hz	
Max power	1,5kW
*Average power cons	0,8kWh
Conn. Cable type H07RN-F	3x1,5mm ²

* This value is subject to variation according to the way in which the equipment is used
NOTE: MORETTI FORNI S.P.A. reserves the right to modify the characteristics of the products illustrated in this publication without prior notice

3 baking chambers height 16+16+22 cm
(assembled with prover height 600mm)

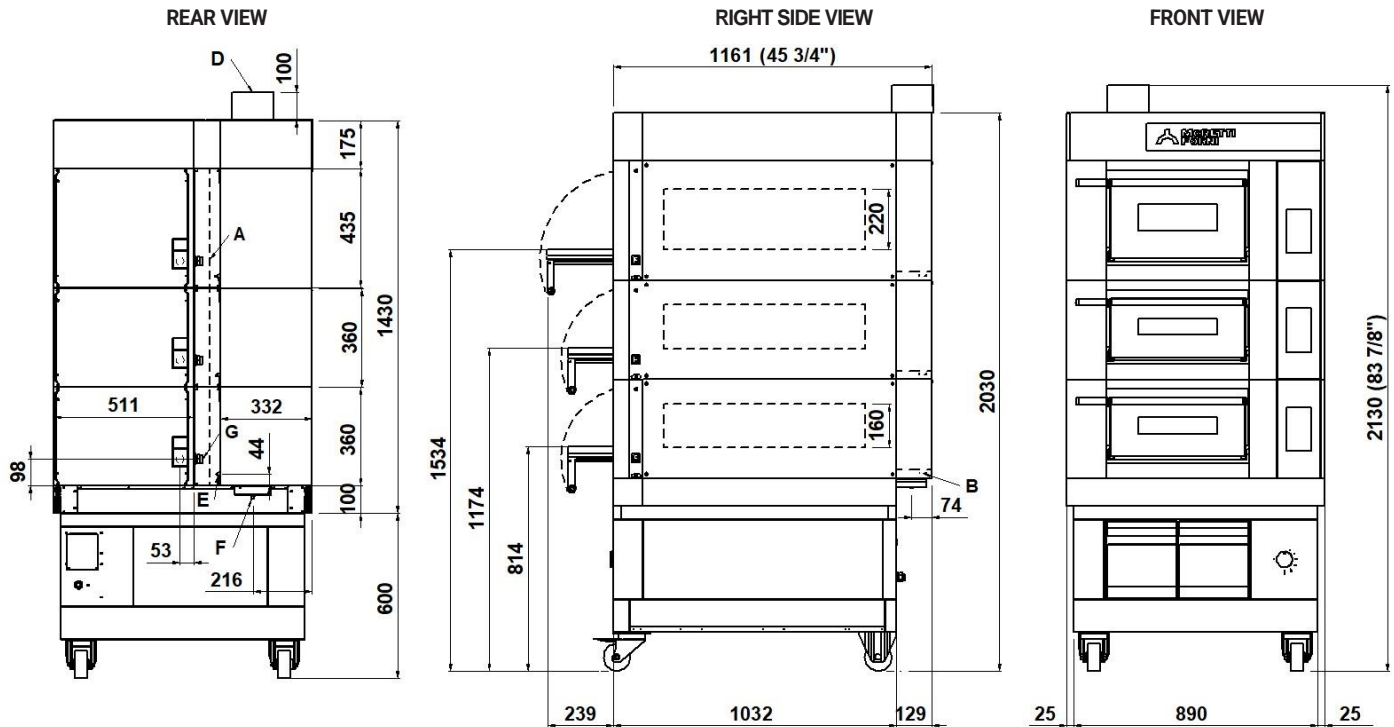

NOTE: The dimensions indicated in the views are in millimetres. *Dimensions refer to the oversized hood.

A steamer 1200W (see data sheet)	B 3/4" male steamer water inlet	D Ø150 steam exhaust	E M6 equipotential screws
F Ø12 condensation exhaust	G fairleads		

DIMENSIONS

External height	1430mm
External depth	1161mm
External width	942mm
Weight	397kg

TOTAL BAKING CAPACITY

Tray (600x400 mm)	3
Pizza diameter 350mm	6
Pizza diameter 450mm	3

SHIPPING INFORMATION

Packed in wooden crate	
Height	1630mm
Depth	1360mm
Width	1150mm
Weight	(397+70)kg

When combined with stand or prover:	
Max height	1995mm
Max weight	(455+80)kg

FEEDING AND POWER

Standard feeding	
A.C. V400 3N	
Feeding on request	
A.C. V230 3	
Frequency	50/60Hz
Max power	13,2kW
*Average power cons	3,6÷4,8kWh
Connecting cable for each chamber	
type H07RN-F	
5x4mm ² (V400 3N)	
4x6mm ² (V230 3)	
Power supply (optional prover)	
A.C. V230 1N 50/60 Hz	
Max power	1,5kW
*Average power cons	0,8kWh
Conn. Cable type H07RN-F	3x1,5mm ²

* This value is subject to variation according to the way in which the equipment is used

NOTE: MORETTI FORNI S.P.A. reserves the right to modify the characteristics of the products illustrated in this publication without prior notice

X50
TECHNICAL DATA

SHIPPING INFORMATION H16		X50E_1_16	X50E_2_16	X50E_3_16
Packed in wooden crate	Height	835mm	1195mm	1555mm
	Weight	(163+50)kg	(276+60)kg	(388+70)kg
When combined with prover or Stand	Max. height.	1785mm	1995mm	2155mm
	Max. weight.	(228+60)kg	(341+70)kg	(446+80)kg
SHIPPING INFORMATION H22		X50E_1_22	X50E_2_22	X50E_3_22
Packed in wooden crate	Height	910mm	1345mm	1780mm
	Weight	(172+50)kg	(293+60)kg	(414+70)kg
When combined with prover or Stand	Max. height.	1860mm	2295mm	2380mm
	Max. weight	(237+60)kg	(358+70)kg	(472+80)kg

* This value is subject to variation according to the way in which the equipment is used
NOTE: MORETTI FORNI S.P.A. reserves the right to modify the characteristics of the products illustrated in this publication without prior notice